

ENGINEERING data
DISCHARGE HEAD

TYPE TF CAST IRON DISCHARGE HEAD

Note: Use Dimensions Shown only when certified by factory

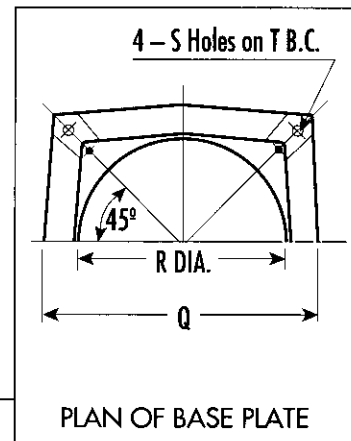
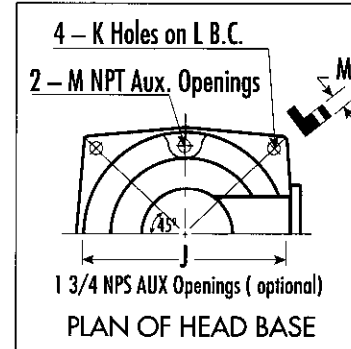
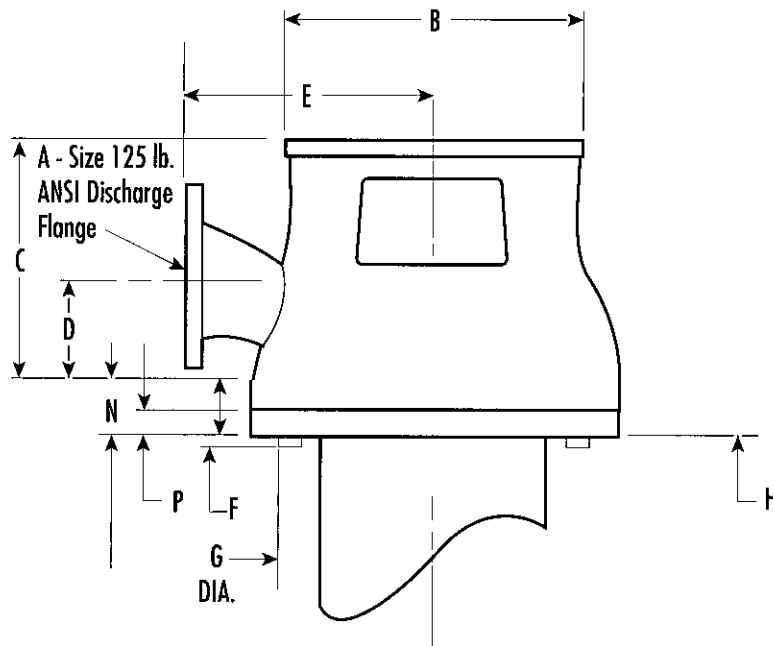

All Dimensions in Inches

HEAD	A	B	C	D	E	F	G	H	HEAD BASE				BASE PLATE					
									J	K	L	M	N	P	Q	R	S	T
TF413	4	13	13	6	11	3	10	1	18	11/16	20	1 3/8	2	1/2	21	17	7/8	24
TF413-17	4	17	13	6	11	3	10	1	18	11/16	20	1 3/8	2	1/2	21	17	7/8	24
TF613	6	13	14	6	11	4	11	1	18	11/16	20	1 3/8	2	1/2	21	17	7/8	24
TF613-17	6	17	14	6	11	4	11	1	18	11/16	20	1 3/8	2	1/2	21	17	7/8	24
TF618	6	16	15	6	14-1/4	4	12 1/2	1	23	13/16	24 1/2	2 1/4	2 3/4	3/4	26 1/2	21 3/4	7/8	28 3/8
TF818	8	18	18	7-1/8	14-1/4	4	13 1/2	1	23	13/16	24 1/2	2 1/8	2 3/4	3/4	26 1/2	21 3/4	7/8	28 3/8
TF825	8	25	20	8-1/8	18-1/4	4	13 1/2	1	31	13/16	33 1/2	2 1/4	3 3/4	1	38	29	1	41
TF1018	10	18	18	8-1/8	14-1/4	4	16	1	23	13/16	24 1/2	2 1/8	2 3/4	3/4	26 1/2	21 3/4	7/8	28 3/8
TF1025	10	25	20	8-1/8	18-1/4	4	16	1	31	13/16	33 1/2	2 1/4	3 3/4	1	36	29	1	41
TF1218	12	18	20	9-5/8	16-1/4	4	19	1	26	13/16	27 3/4	1 7/8	3 1/4	7/8	32	24	7/8	33 1/2
TF12251	12	25	21	9-5/8	18-1/4	5	21	1 1/2	31	13/16	33 1/2	2 1/4	3 3/4	1	38	29	1	41





Cast Iron Discharge Head Assy Type TF Open Line Shaft

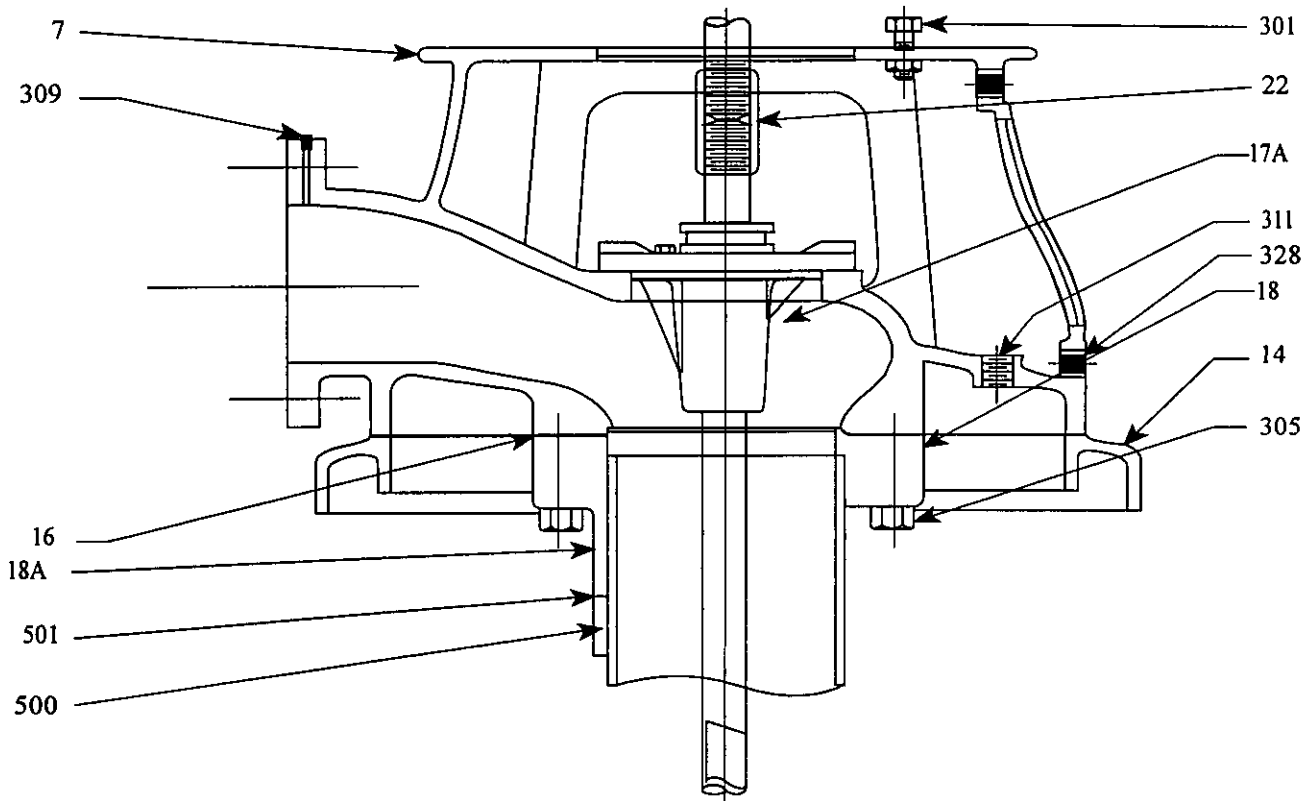

Item No.	Part Name	Material	
		Standard	Optional
7A	Discharge Head Assembly	-----	
7	Discharge Head	C.I. CL.30	
14	Soleplate	C.I. CL.30	
16	Gasket , Top Col. Flg / Head	Non - Asb.	
17A	Stuffing Box Assembly	See Dwg No. _____	
18	Top Col. Flange , Butt	C.I. CL.30	
18A	Top Col. Flange , Adjustable	Ductile C.I.	
22	Head Shaft Coupling	Carbon Steel	
301	Fastener , Driver / Head	Carbon Steel	
305	Cap Screw , Top Col. Flg / Head	Carbon Steel	
309	Plug , Gauge Conn - 1 / 4" NPT	Cast Iron	
311	Plug , Aux Opening (2)	Cast Iron	
328	Drain Conn , 1 / 2" NPT		
500	Packing Ring	C.I. CL.30	
501	Lampwick Packing	-----	

CROSS-SECTIONAL DRAWING

DRAWING NO. _____

DATE: _____

TYPE UF DISCHARGE HEAD OPEN LINE SHAFT

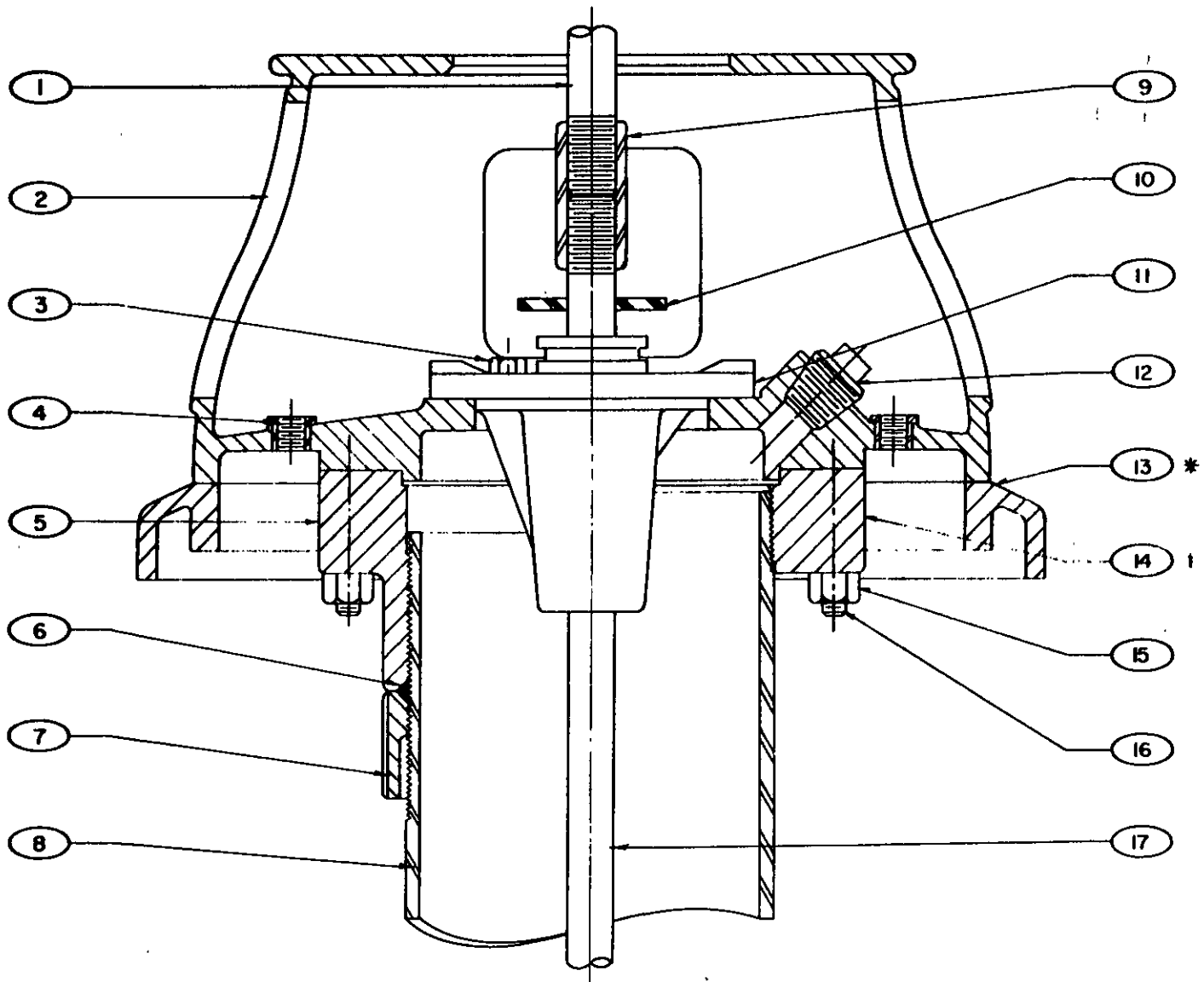

† FURNISH WHEN UNDERGROUD IS IN TOP COL. SECTION UNLESS ADJ. TYPE IS SPECIFIED

* NOT FURNISHED UNLESS SPECIFIED BY CUSTOMER

ITEM NO.	DESCRIPTION
1	MOTOR DRIVE SHAFT
2	DISCHARGE HEAD
3	CAPSCREW, STUFFING BOX
4	AUXILIARY OPENING
5	ADJ. TOP COLUMN FLANGE
6	PACKING
7	PACKING RING
8	TOP COLUMN PIPE

ITEM NO.	DESCRIPTION
9	HEAD COUPLING
10	WATER SLINGER
11	STUFFING BOX ASSEMBLY
12	PIPE PLUG, AIR RELEASE
13	BASE PLATE
14	TOP COL. FLANGE, 3/4" TAPER/FT.
15	HEX NUT
16	STUD
17	LINE SHAFT

IN ORDERING REPLACEMENT PARTS, SPECIFY PART DESCRIPTION & PUMP SERIAL NO.