

ENGINEERING data
STUFFING BOX

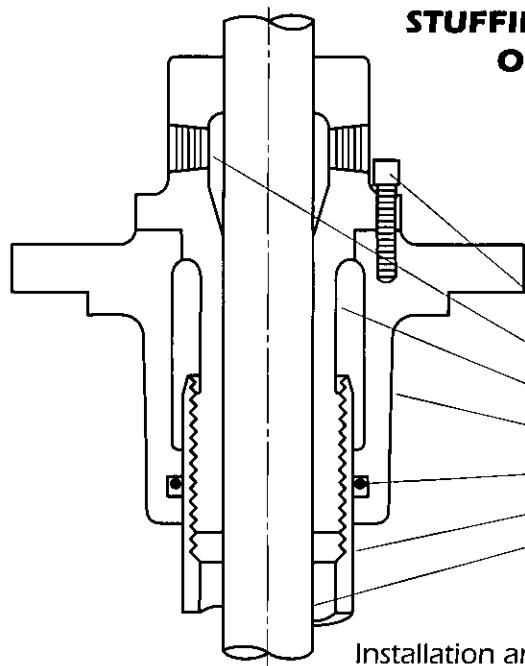

STUFFING BOX ASSEMBLY
Oil Lubrication
Style 60

PART NAME	MATERIAL	
	STANDARD	SPECIAL
LOCK SCREW	STEEL	
OIL INLET	—	
TENSION BEARING	BRONZE	
TENSION BOX	CAST IRON	
O' RING	BUNA-N	
TUBING	C.S.-SCH 80 PIPE	
LINE SHAFT	C-1045 CAR. STL.	

In ordering replacement parts, specify parts description and pump serial no

Installation and Operating Instructions

- 1 REMOVE THE LOCK SCREW AND THE O-RING AND THOROUGHLY CLEAN THE TENSION BOX INCLUDING THE O-RING GROOVE REMOVE ANY NICKS OR BURRS FROM THE UPPER AND LOWER MOUNTING FACES AND MALE REGISTER WITH A FINE FLAT FILE RE-INSTALL AND LIGHTLY OIL THE EXPOSED SURFACE OF THE O-RING
- 2 CLEAN THE SURFACE OF THE HEAD THAT RECEIVES THE TENSION BOX AND REMOVE ANY NICKS OR BURRS WITH A FINE FLAT FILE
- 3 CAREFULLY INSTALL THE TENSION BOX, ALIGN THE MOUNTING HOLES WITH THE TAPS IN THE HEAD AND SEAT THE BOX TO THE HEAD INSTALL AND EVENLY TIGHTEN THE MOUNTING CAP SCREWS
- 4 CLEAN THE TENSION BEARING THOROUGHLY AND REMOVE ANY NICKS OR BURRS FROM THE MOUNTING FACE AND REGISTER WITH A FINE FILE REMOVE ANY NICKS OR BURRS FROM THE THREADS WITH A THREE CORNERED FILE
- 5 OIL THE THREADS AND THE BORE AND CAREFULLY PLACE THE TENSION BEARING OVER THE SHAFT AND THREAD (RIGHT HAND) INTO THE TUBING CONTINUE THREADING UNTIL THE LOWER FLANGE FACE FIRMLY CONTACTS THE TENSION BOX FACE
- 6 FOR THE PROPER AMOUNT OF TUBE TENSION, REFER TO INSTALLATION MANUAL PAGE 19 FOR SETTINGS LESS THAN 100 FEET TIGHTEN TO THE NEAREST LOCKING POSITION

IMPORTANT

PRIOR TO INITIAL START-UP AND AFTER A SHUT DOWN OF 150 HOURS OR LONGER, THE LUBRICATOR SHOULD BE ADJUSTED FOR THE RECOMMENDED NUMBER OF DROPS PER MINUTE AS OUTLINED IN CHART 2 AND ALLOWED TO OPERATE AT THIS RATE PER 20 MINUTES FOR EACH 100 FEET OF SETTING

FOR NORMAL OPERATION THE LUBRICATOR SHOULD BE ADJUSTED IN ACCORDANCE WITH CHART 2

CHART 2

SHAFT SIZE	"A"	"B"
	LUBRICATOR SETTING IN DROPS PER MIN	DROPS PER MIN. PER EACH 100 FT SETTING
7/8- 1 3/16	8	2
1 1/2- 1 11/16	7	3
1 15/16- 2 7/16	10	4
2 11/16	12	5

$$\text{TOTAL DROPS/MIN} = \text{"A"} \times \frac{\text{[SETTING]}}{100} \times \text{"B"}$$

EXAMPLE 500 FEET OF 1 11/16" X 2 1/2"

$$\text{TOTAL DROPS/MIN} = 7 \times \frac{(500 \times 3)}{100} = 7 + (5 \times 3) = 7 + 15 = 22$$

- 9 THE LUBRICATOR SHOULD BE CHECKED PERIODICALLY AND RESET IF REQUIRED TO MAINTAIN THE PROPER FLOW

THE APPROXIMATE NUMBER OF HOURS OF CONTINUOUS OPERATION AT VARIOUS FLOW CAN BE FOUND IN CHART 3 IT IS GENERALLY RECOMMENDED THAT THE LUBRICATOR BE FILLED WHEN IT IS ONE QUARTER FULL

CHART 3

FLOW RATE DROPS/MIN	NUMBER OF HOURS OF CONTINUOUS OPERATION		
	LUBRICATOR CAPACITY		
	1 QUART	2 QUART	3 QUART
5	110	220	440
10	55	110	220
15	38	75	180
20	28	56	110
25	22	45	90
30	19	38	75
40	14	28	55
50	11	22	45

CHART 1

SIZE TUBING	1 1/4"	1 1/2"	2"	2 1/2"	3"	3 1/2"	4" & UP
NO THD'S/IN	16	12	10	10	8	10	10
"A"	063"	083"	100"	100"	125"	100"	

"A" AMOUNT OF PULL-UP FOR EACH COMPLETE TURN OF THE TENSION BEARING THE TOTAL NUMBER OF TURNS REQUIRED CAN BE CALCULATED BY DIVIDING THE FIGURE ABOVE INTO THE TENSION FIGURE FROM PAGE 19 OF THE INSTALLATION MANUAL

IF AFTER ADJUSTING THE TENSION BEARING THE PROPER NUMBER OF TURNS NO SLOT ALIGNS WITH THE LOCK SCREW TAP IN THE BOX IT IS RECOMMENDED THAT THE BEARING BE BACKED OFF TO THE NEAREST ALIGNMENT POSITION IF IT TAKES MORE THAN AN EIGHTH TURN FORWARD TO ACHIEVE ALIGNMENT

- 7 INSTALL AND TIGHTEN THE LOCK SCREWS
- 8 CONNECT THE LUBRICATOR TO THE OIL CONNECTION IN THE TENSION BEARING FILL THE LUBRICATOR WITH A GOOD GRADE MINERAL OIL HAVING A VISCOSITY RATING OF APPROXIMATELY SAE 10 AND HAVING A RELATIVELY LOW COLD POUR POINT.





TUBE TENSION ASSEMBLY OIL LUBRICATION STYLE 60

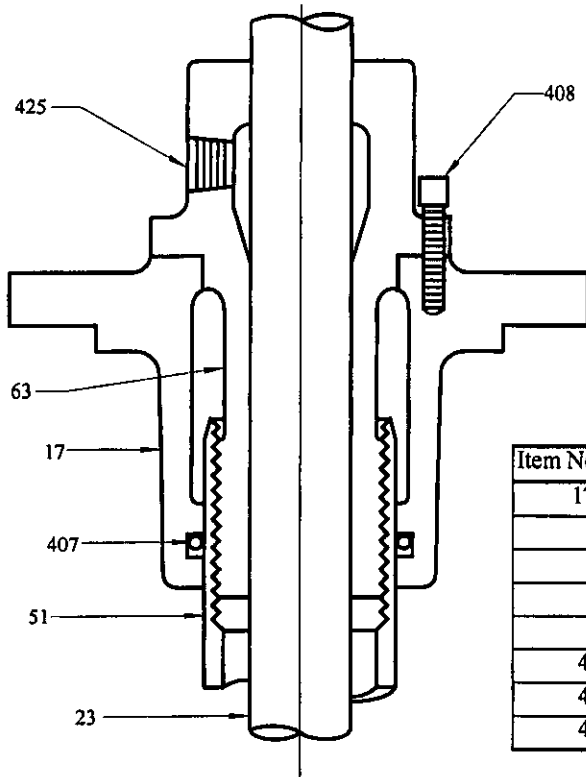

Item No.	Part Name	Material	
		Standard	Optional
17A	Tube Tension Assembly	-----	
17	Tension Box	Bronze	
23	Head Shaft	C-1045 Car. Stl	
51	Tubing	C.S.-SCH. 80 Pipe	
63	Tension Bearing	Bronze	
407	O-Ring	Buna-N	
408	Lock Screw	Steel	
425	Lub Conn.	-----	

INSTALLATION AND OPERATING INSTRUCTIONS

- REMOVE THE LOCK SCREW AND THE O-RING AND THOROUGHLY CLEAN THE TENSION BOX INCLUDING THE O-RING GROOVE. REMOVE ANY NICKS OR BURRS FROM THE UPPER AND LOWER MOUNTING FACES AND MALE REGISTER WITH A FINE FLAT FILE. RE-INSTALL AND LIGHTLY OIL THE EXPOSED SURFACE OF THE O-RING.
- CLEAN THE SURFACE OF THE HEAD THAT RECEIVES THE TENSION BOX AND REMOVE ANY NICKS OR BURRS WITH A FINE FILE.
- CAREFULLY INSTALL THE TENSION BOX, ALIGN THE MOUNTING HOLES WITH THE TAPS IN THE HEAD AND SEAT THE BOX TO THE HEAD. INSTALL AND EVENLY TIGHTEN THE MOUNTING CAPSCREWS.
- CLEAN THE TENSION BEARING THOROUGHLY AND REMOVE ANY NICKS OR BURRS FROM THE MOUNTING FACE AND REGISTER WITH A FINE FILE. REMOVE ANY NICKS OR BURRS FROM THE THREAD WITH A THREE CORNERED FILE.
- OIL THE THREADS AND THE BORE AND CAREFULLY PLACE THE TENSION BEARING OVER THE SHAFT AND THREAD (RIGHT HAND) INTO THE TUBING. CONTINUE THREADING UNTIL THE LOWER FLANGE FACE FIRMLY CONTACTS THE TENSION BOX FACE.
- FOR THE PROPER AMOUNT OF TUBE TENSION, REFER TO INSTALLATION MANUAL PAGE 19. FOR SETTINGS LESS THAN 100 FEET, TIGHTEN TO THE NEAREST LOCKING POSITION.

CHART 1

SIZE TUBING	1 1/4"	1 1/2"	2"	2 1/4" - 3"	3 1/2"	4" & UP
NO.	16	12	10	10	8	10
THD/IN						
"A"	.063"	.083"	.100"	.100"	.125"	.100"

"A" = AMOUNT OF PULL-UP FOR EACH COMPLETE TURN OF THE TENSION BEARING. TOTAL NUMBER OF TURNS REQUIRED CAN BE CALCULATED BY DIVIDING THE FIGURE ABOVE INTO THE TENSION FIGURE FROM PAGE 19 OF THE INSTALLATION MANUAL.

IF AFTER ADJUSTING THE TENSION BEARING THE PROPER NUMBER OF TURNS, NO SLOT ALIGNS WITH THE NEAREST ALIGNMENT POSITION IF IT TAKES MORE THAN AN EIGHTH TURN FORWARD TO ACHIEVE ALIGNMENT.

- INSTALL AND TIGHTEN THE LOCK SCREWS.
- CONNECT THE LUBRICATOR TO THE OIL CONNECTION IN THE TENSION BEARING. FILL THE LUBRICATOR WITH A GOOD GRADE MINERAL OIL HAVING A VISCOSITY RATING OF APPROXIMATELY SAE 10 AND HAVING A RELATIVELY LOW COLD POUR POINT.

IMPORTANT:

PRIOR TO INITIAL START-UP AND AFTER A SHUT DOWN OF 150 HOURS OR LONGER. THE LUBRICATOR SHOULD BE ADJUSTED FOR THE RECOMMENDED NUMBER OF DROPS PER MINUTE AS OUTLINED IN CHART 2 AND ALLOWED TO OPERATE AT THIS RATE PER 20 MINUTES FOR EACH 100 FEET OF SETTING

CHART 2

SHAFT SIZE	"A" LUBRICATOR SETTING IN DROPS PER MIN.	"B" DROPS PER MIN. PER EACH 100 FT. SETTING
1/2" - 1 1/16"	5	2
1 1/4" - 1 1/16"	7	3
1 1/2" - 2 7/16"	10	4
2 1/16"	12	5

$$\text{TOTAL DROPS / MIN.} = "A" + (\text{SETTING} / 100 \times "B")$$

EXAMPLE: 500 FEET OF 1 1/16" X 2 1/2"

$$\text{TOTAL DROPS / MIN.} = 7 + (500 / 100 \times 3) = 7 + (3 \times 3) = 7 + 15 = 22$$

- THE LUBRICATOR SHOULD BE CHECKED PERIODICALLY AND RESET IF REQUIRED TO MAINTAIN THE PROPER FLOW

THE APPROXIMATE NUMBER OF HOURS OF CONTINUOUS OPERATION AT VARIOUS FLOW RATINGS CAN BE FOUND IN CHART 3. IT IS GENERALLY RECOMMENDED THAT THE LUBRICATOR BE REFILLED WHEN IT IS ONE QUARTER FULL.

CHART 3

FLOW RATE DROPS / MIN.	NUMBER OF HOURS OF CONTINUOUS OPERATION LUBRICATOR CAPACITY		
	1 QUART	2 QUART	STD. STL. TANK
5	110	220	440
10	55	110	220
15	36	75	130
20	26	55	110
25	22	45	90
30	19	38	75
40	14	28	55
50	11	22	45

DRAWING NO. _____

DATE: _____

CROSS-SECTIONAL DRAWING



A Marley Company
LAYNE & BOWLER, INC.
 MEMPHIS, TN 38108 USA

SECTIONAL DRAWING

5 QUART OIL TANK ASSEMBLY

MANUAL OR SOLENOID DRIP FEED OPERATION

SECTION 9100
 DRWG. NO. 8511-L01A
 DATE Nov. 1, 1978
 SUPERSEDES

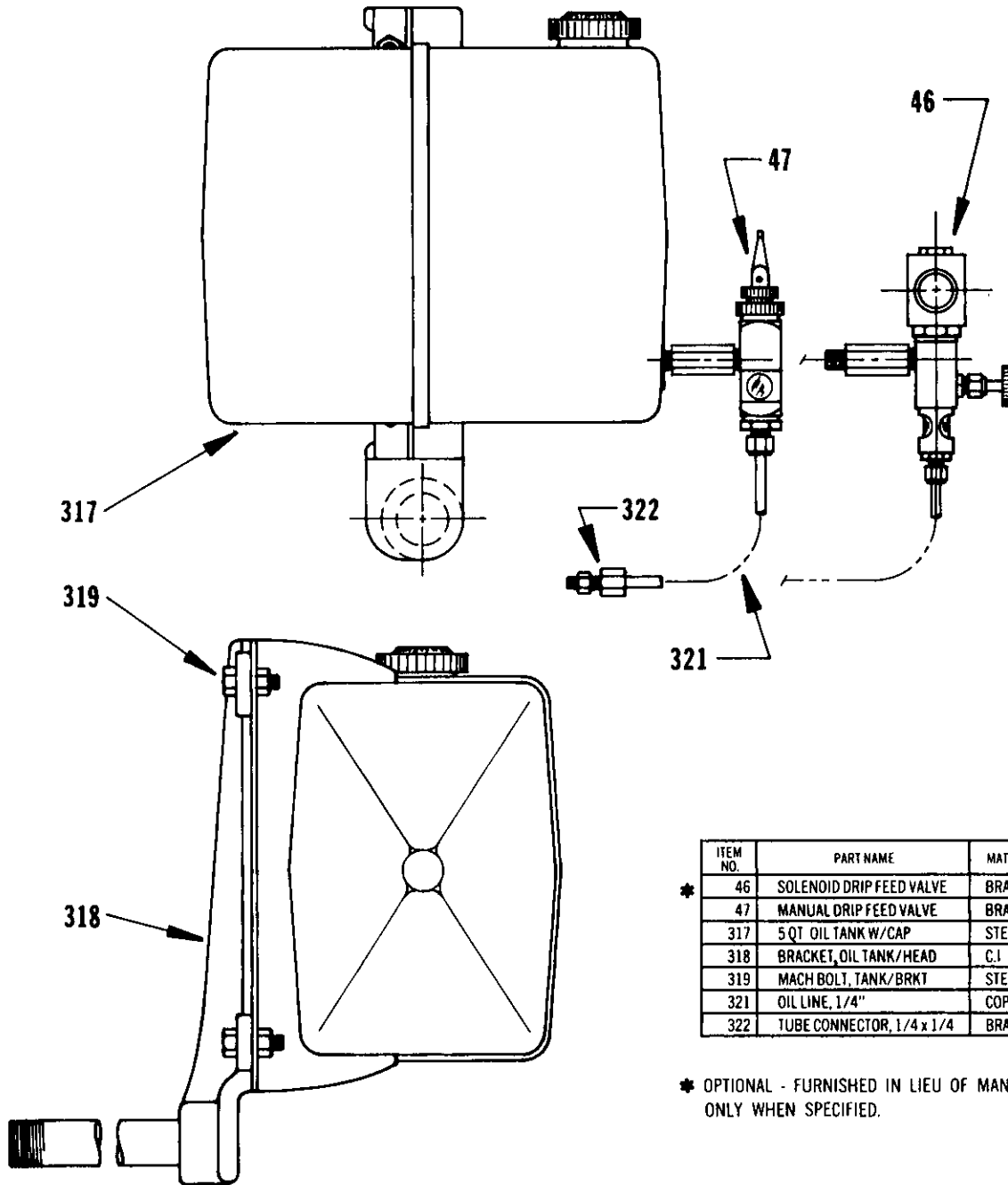

ITEM NO.	PART NAME	MATERIAL
* 46	SOLENOID DRIP FEED VALVE	BRASS
47	MANUAL DRIP FEED VALVE	BRASS
317	5 QT. OIL TANK W/CAP	STEEL
318	BRACKET, OIL TANK/HEAD	C.I. & STL
319	MACH BOLT, TANK/BRKT	STEEL
321	OIL LINE, 1/4"	COPPER
322	TUBE CONNECTOR, 1/4 x 1/4	BRASS

* OPTIONAL - FURNISHED IN LIEU OF MANUAL VALVE ONLY WHEN SPECIFIED.



LAYNE & BOWLER,
 1993 Chelsea Avenue
 P.O. Box 8097
 Memphis, Tennessee 38108
 Phone: 901/724-8300



DWG NO: _____
 DATE: _____

ESSEX LUBRICATOR SOLENOID OPERATED ___QT. CAPACITY

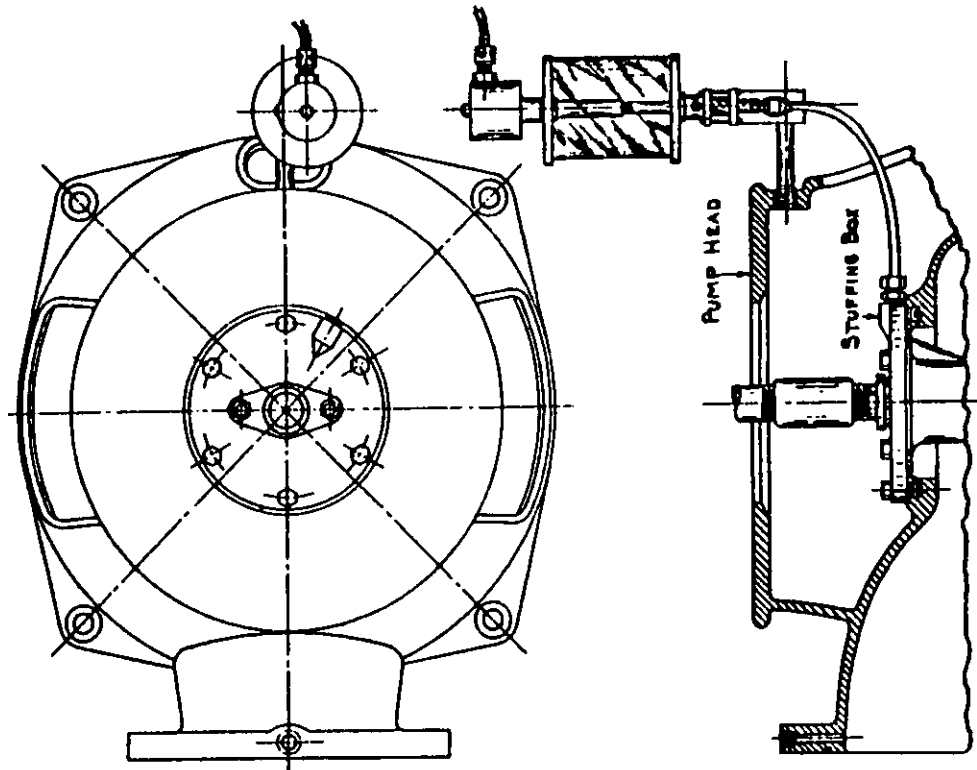
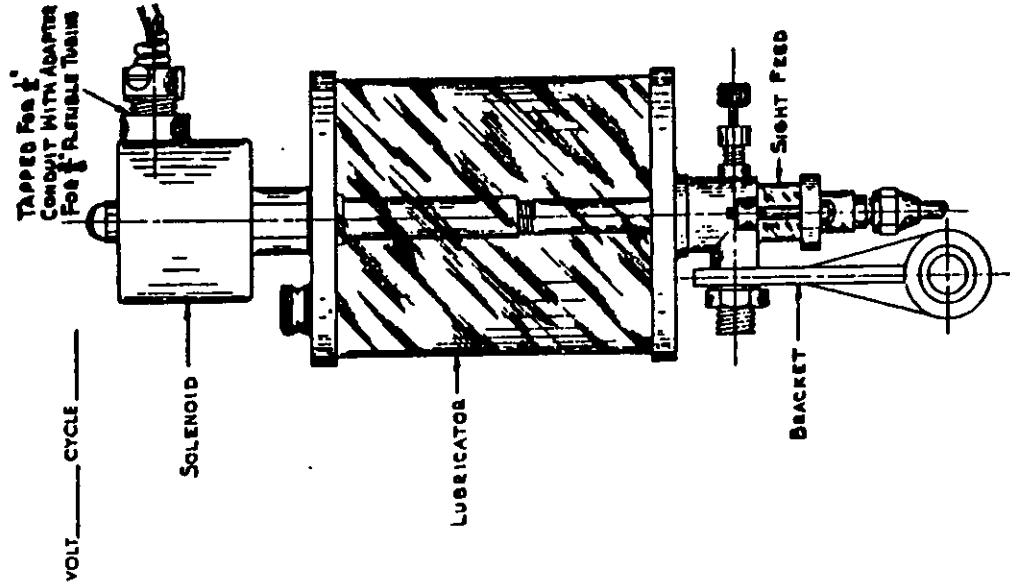

PRINTED IN U.S.A.