



AURORA[®] LAYNE VERTI-LINE SERIES
6EM – 18GM 1100
VERTICAL TURBINE PUMPS
(COLLETED IMPELLERS)

INSTALLATION OPERATION AND MAINTENANCE MANUAL

NOTE! To the installer: Please make sure you provide this manual to the owner of the equipment or to the responsible party who maintains the system.

PUMP IDENTIFICATION

Carefully record all of the following data from your pump nameplate. It will aid in obtaining the correct replacement parts for your pump. In addition to the nameplate, the pump serial number is stamped on the discharge flange.

Pump: Serial Number _____

Model Number _____

Pump Size _____

Number of Stages _____

GPM _____

Head (feet) _____

Motor: Manufacturer _____

Horsepower _____

Serial Number _____

Motor Frame _____

Full Load Speed _____

Full Load Amps _____

Phase/Hz/Volts _____

Date Placed In Service _____

Gear: Manufacturer _____

Serial Number _____

Model Number _____

Ratio _____

Rotation Figure _____

6EM THRU 18GM- 17100 VERTICAL TURBINE PUMPS (COLLETED IMPELLERS)

INSTALLATION, OPERATION AND MAINTENANCE

TABLE OF CONTENTS

Warranty Highlights.....	4	Insufficient Pressure or Flow.....	34
Introduction.....	5	Loss of Suction Operation.....	34
<u>Section 1 General</u>		Excessive Power Consumption	34
Safety.....	6	Vibration or Noise.....	35
Storage of Pumps.....	7	Excessive Packing Box Leakage.....	35
Consider a Unit in Storage.....	7	Over-Heating.....	35
Assembled Pumps.....	7	Motor Symptoms.....	35
Unassembled Pumps.....	8	Motor Does Not Start	36
<u>Section 2 Introduction</u>		Motor Fails To Come Up To Speed.....	36
General Description	9	Motor Runs Hot.....	36
Bowl Assembly.....	9	Motor Vibrates.....	37
Column Pipe.....	9	Motor Is Noisy	37
Line Shafting.....	9	Incorrect Rotation.....	37
Discharge Heads.....	10	<u>Section 5 Maintenance</u>	
Drivers.....	10	Preventive Maintenance.....	38
<u>Section 3 Installation</u>		Grease Recommendation.....	38
General.....	11	Mechanical Seal.....	38
Foundation.....	11	Packing Adjustment	38
Well and Pit Inspection	11	Packing Replacement.....	39
Bowl Assembly	12	Pump Disassembly	39
Suction Strainer.....	12	Driver Removal.....	39
Hoisting, Leveling, Grouting & Piping.....	12	Vertical Hollow Shaft(VHS) Driver.....	39
Pump Assembly.....	13	Vertical Solid Shaft (VSS) Driver.....	40
Product Lubricated Open Line Shaft.....	13	Discharge Head Removal.....	40
Oil Lube Enclosed Line Shaft.....	17	Column Removal	41
Water Flush Enclosed Line Shaft.....	21	Pump Bowl Disassembly	42
Driver Installation	24	Inspection for Replacement.....	43
Vertical Hollow Shaft Drivers.....	25	Shaft Straightness.....	44
Vertical Solid Shaft Drivers	27	Pump Bowl Assembly	44
Style II Coupling	27	Wear Rings.....	46
Style IV Coupling.....	29	Mechanical Seals.....	46
<u>Section 4 Operation</u>		Assembly Tools	49
General.....	32	Maintenance History	54
Before Starting the Pump.....	32	Maintenance Notes.....	55
Operating at Reduced Capacity	32	<u>Section 6 Repair Parts</u>	
Initial Startup.....	32	Ordering Parts.....	56
Normal Operation.....	33	Recommended Spare Parts	56
Shutdown.....	33	Returning Parts	56
Seasonal Operating Instructions.....	33	Predicted Life.....	56
Emergency Procedures.....	33	Service.....	57
Start-Up.....	33	Warranty Service	57
Shut-Down.....	33	Service After Warranty.....	57
Troubleshooting.....	34	<u>Section 7 Reference Information</u>	
Pump Symptoms.....	34	Technical Data.....	58
		Drawings and Diagrams.....	63

WARRANTY HIGHLIGHTS

1. Seller warrants products of its own manufacture against defects in materials and workmanship under normal use and service for one (1) year from date of installation or start-up, but not more than eighteen (18) months after date of shipment.
2. Accessories and components not manufactured by seller are warranted only to the extent of the original manufacturer's warranty.
3. No allowances will be made for repairs or alterations effected without specific written authorization from Seller.
4. The equipment as manufactured by Layne/Verti-Line is precision machinery. Proper care can give a lifetime of satisfactory service. Guarantees of performance and warranties are based on the use of original equipment manufactured (OEM) replacement parts. Layne/Verti-Line assumes no responsibility when alterations, non-authorized design modifications and/or non-OEM replacement parts are incorporated.
5. This warranty is VOID unless the purchaser provides protective storage, installs and maintains the equipment in accordance with manufacturer's instructions.
6. Under the terms of this warranty, Seller shall not be responsible nor liable for:
 - a. Consequential, collateral or special losses or damages.
 - b. Equipment conditions caused by fair wear and tear, abnormal conditions of use, accident, neglect, or misuse of said equipment.
 - c. Labor charges, loss or damage resulting from supplying of defective part(s) or improper repairs by unauthorized person(s).
 - d. Damage caused by abrasive materials, chemicals, scale deposits, corrosion, lightning, improper voltage or mishandling.
 - e. Labor charges for installation, removal or reinstallation of equipment.
7. The above listed warranty highlights do not constitute our total terms and conditions regarding warranty. For complete warranty information please refer to complete warranty statement herein.

LOSS OR DAMAGE IN TRANSIT

Immediately upon receipt a complete inspection and accounting against the packing list should be made of all major components, and accompanying boxes or pallets.

All material is shipped F.O.B. our factory, or our vendor's shipping point unless other, contractual, arrangements are made. Under these terms, any claims for loss or damage in transit should be immediately directed to the delivering freight carrier.

Layne/Verti-Line will assist the customer in receiving fair compensation, but assumes no responsibility to mediate such claims. This policy includes shipments wherein Layne/Verti-Line pays freight costs as part of the sales terms.

INTRODUCTION

Congratulations! You are the owner of the finest pump commercially available. If you give it the proper care as outlined and recommended by this manual, it will provide you with reliable service and long life.

IMPORTANT

Read this complete manual and manuals for all component equipment before assembly or installation is started. It contains information which is the result of engineering and research efforts. It is designed to supply adequate instructions for the installation, operation and maintenance of your pump. Failure or neglect to properly install, operate or maintain your pump may result in personal injury, property damage or unnecessary damage to the pump.

This manual applies to the pump installation, operation and maintenance. If your operating conditions ever change, always refer to the factory for reapplication. Always refer to the manuals provided by manufacturers of the accessory equipment for their separate instructions.

Variations exist in both the equipment used with these pumps and in the particular installation of the pump and driver. Therefore, specific operating instructions are not within the scope of this manual. This manual contains general rules for installation, operation and maintenance of the pump. If there are questions regarding the pump or its application which are not covered in this manual, please contact the factory as follows:

Kansas City, Kansas:

Layne/Verti-Line
3601 Fairbanks Avenue
Kansas City, KS 66106
(913) 371-5000
Fax: (913) 748-4030

To obtain additional data on hydraulics and pump selection and operation, we suggest you purchase the following reference books:

1. Hydraulic Institute Standards

Hydraulic Institute
9 Sylvan Way
Parsippany, NJ 07054-3802

2. Hydraulic Handbook

Fairbanks Morse Pump
3601 Fairbanks Avenue
Kansas City, KS 66106

CALIFORNIA PROPOSITION 65 WARNING:

This product and related accessories contain chemicals known to the State of California to cause cancer, birth defects or other reproductive harm.

SECTION 1 GENERAL

Safety

Safety should be of utmost importance when in close proximity of this pumping equipment. Before attempting to operate this equipment, you should read this manual in its entirety, taking special notice of all cautions, warnings and/or danger notifications. These warnings apply to pumps supplied by Layne/Verti-Line. Refer to the manuals supplied by the driver and control manufacturer for additional warnings before operating this equipment.

The words **DANGER**, **WARNING** and **CAUTION** have different connotations and are generally defined as follows:

DANGER
Indicates an imminently hazardous situation which, if not avoided, will result in death or serious injury.
WARNING
Indicates a potentially hazardous situation which, if not avoided, will result in serious injury.
CAUTION
Indicates a potentially hazardous situation which, if not avoided, may result in minor or moderate injury or may indicate that improper practices will result in equipment malfunction or failure. It may also be used to alert against unsafe practices.
IMPORTANT
Indicates the highlight or accent of specific information.
NOTE
Specific information useful in maintaining the equipment.

The installation, use and operation of this type of equipment is affected by various Federal, State and Local Laws and the regulations concerning OSHA. Compliance with such laws relating to the proper installation and safe operation of this type of equipment is the responsibility of the equipment Owner and all necessary steps should be taken by the Owner to assure compliance with such laws before operating the equipment.

DANGER
Do not attempt to service the pump until the electrical power has been disconnected and it has been verified that the pump cannot start. Because many installations utilize automatic starting equipment, the pump unit may start at any time without warning. Proper precautions should be taken to avoid injury as a result of automatic starting of the equipment.
DANGER
Do not operate the pump without guards in place over the rotating parts. Exposed rotating parts can catch clothing, fingers, or tools, causing severe injury to personnel. Any operation of this machine without a protective guard can result in severe bodily injury. The responsibility for the installation of protective guards is that of the equipment owner.
DANGER
This pump is designed for the exclusive use of pumping water. It should not be used for pumping other media unless a specific Purchase/Buyer agreement is negotiated.

WARNING

Do not attempt to try to clean the pump with bare hands. The pumped material may contain items that may present health hazards such as needles, and other sharp objects. Always wear heavy puncture resistant gloves.

Before attempting to service this pump:

1. Familiarize yourself with this manual.
2. Disconnect or lock out the power source to insure the pump will not start. **Confirm power source disconnect** with appropriate electrical test equipment.
3. Close the discharge valve.

After the pump has been installed, make certain that the pump and all piping connections are tight and are properly supported prior to start-up and operation.

WARNING

Certain procedures in disassembly and assembly require parts be heated to high temperatures. Heat resistant gloves must be worn when handling heated parts. Heated parts **can cause severe** personal injury.

CAUTION

For pumps used in potable water service, all thread lubrication, grease, cleaning materials and paint must be suitable for potable water. Do not attempt to try to clean the pump with bare hands.

CAUTION

On deep set open line shaft turbines (where static water level is 50' or greater) it is recommended that the line shaft bearings be pre-lubricated prior to the start of the pump. The discharge head is provided with a port to accommodate pre-lubrication piping. Refer to the factory for specific pre-lubrication instructions.

Storage of Pumps**CAUTION**

If the equipment is not to be immediately installed and operated, **THE FOLLOWING INSTRUCTIONS SHOULD BE ADHERED TO AS A MINIMUM:**

Consider a unit in storage when:

1. It has been delivered to the job site and is awaiting installation.
2. It has been installed but operation is delayed pending completion of plant construction.
3. There are long (30 days or more) periods between operation cycles.
4. The plant (or facility) is shut down.

NOTE

Improper storage could result in product failures or restoration not covered by warranty.

Assembled Pumps:

1. Remove the gland halves, packing and seal water rings from the stuffing box if the pump is so equipped. If the pump is equipped with inside mechanical seal, remove the pipe plug in the stuffing box cover, and coat the seal with light oil. This may be done by using an oil can, squirting the seal through the tapped opening while rotating the pump shaft. If equipped with outside seal, oil and cover for protection.
2. When pumps with rubber bearings are stored assembled in horizontal position, it is necessary to rotate the entire pump and column assembly 90 degrees once per month. This practice will help prevent the weight of the shafts from deforming the rubber bearings. Pumps with metal bearings stored in horizontal positions are to have shafts rotated once per month to

prevent line shafts from deforming or bowing under their own weight.

3. Pumps stored fully assembled and installed are to be rotated once per week to prevent brinelling of motor thrust bearings. Packing or mechanical seals are to be serviced as noted above.

Unassembled Pumps:

1. Store the unassembled components in a clean, dry well-ventilated place free from vibrations, moisture, and temperature variation.
2. Wipe clean all exposed machined surfaces and coat with a heavy layer of grease or other equivalent rust preventative material.
3. Cover the suction and discharge of the pump with cardboard or wood to prevent entry of foreign material or varmints. This also applies to column sections.
4. The bearings, shaft, and couplings should be stored as components, i.e., shaft with couplings installed on lower ends. The ends should then be wrapped with heavy plastic or protective material and secured tightly to prevent entry of foreign matter and varmints.

SECTION 2

INTRODUCTION

General Description

A vertical line shaft turbine pump consists of five basic components. These components are the pump bowl assembly, column pipe, line shafting, discharge head, and driver. Refer to the drawing section for general arrangement drawings.

Bowl Assembly

The 1100 series single stage bowl assembly is made up of a suction bell (or suction case), a top intermediate bowl and impeller, and a discharge case. Units of two or more stages include a suction bell (or suction case), multiple intermediate bowls and impellers. Multiple stage open line shaft construction does not require a discharge case. Refer to the assembly drawing found in the drawing section of this manual for your specific configuration.

Column Pipe

Column pipe for pumps covered in this manual can be either threaded or flanged. Threaded column features straight threads on both column ends and butt solidly together within the coupling. Standard nominal column lengths for threaded column are 5 foot, 10 foot or any special length up to 10 foot.

Flanged column includes registered fits for accurate column alignment and are bolted together. Flanged column pipe is available in standard lengths of 10 foot or 5 foot; or can be provided in any special length up to 10 foot.

Line Shafting

The turbine line shaft transmits torque from the pump driver to the pump bowl assembly and rotates inside the column pipe. Both ends of the shaft are precision machined, and are secured together with couplings. This shafting is supported by bearings at specific intervals; the types of bearings used and how they are lubricated are described as follows:

A. Open Line Shaft - Product Lubricated

This design is such that the line shaft and bearings are exposed to and lubricated by the liquid being pumped. The line shaft is supported at intervals of not more than 10' by bearings that run on shaft sleeves. Support for these bearings is supplied by bearing retainers. The outer hub of the retainer is seated between the two column ends. Refer to the specific assembly drawings found in the drawing section of this manual.

B. Enclosed Line Shaft

In the enclosed line shaft design shafting is surrounded by tubing. This tubing protects both the shaft and bearings from the pumped liquid and provides a channel for lubricating the shaft bearings. The bearings have machined grooves on their I. D. to allow lubrication to flow from one bearing to the next. These bearings are also threaded on the outside diameter and are used to connect the five foot enclosing tube sections. Lubrication is normally oil from a separate source. The enclosing tube may be supported by spiders unequally spaced to reduce the risk of vibration. (See the Technical Data Section.)

Discharge Heads

Discharge heads perform multiple functions: direct the pump flow from the pump column to the discharge piping system, provide a method for sealing the line shaft, provide a base from which the pump is suspended, and provide a mounting surface for the driver.

Surface discharge heads incorporate both the discharge elbow and driver pedestal in one piece. An underground discharge elbow can also be provided in which case a separate driver pedestal is provided. The bottom surface of the discharge head or pedestal is machined when furnished with a sole plate.

Drivers

A variety of driver sizes and types can be supplied based on the specific job requirements. Drivers may be either vertical hollow or vertical solid shaft motors or right angle gears connected to horizontal shaft drivers.

Normally a vertical hollow shaft driver is used. In this configuration, the line shaft passes through the driver, positioned with an adjusting nut to accommodate impeller adjustment, and is connected to the top of the driver by a keyed drive hub or coupling. Solid shaft drivers require special adjustable couplings in order to attach to the pump shaft and to accommodate impeller adjustment. Refer to your submittal package for your specific pump driver configuration.

SECTION 3 INSTALLATION

General

CAUTION

Turbine pumps are shipped with a shaft bolt installed in the suction bell to protect the pump from damaging shaft movement during transit. It is imperative that the retaining bolt be removed, and grease added to the lower bearing cavity (if not already packed). Install the suction bell plug prior to pump installation. Failure to follow these instructions will result in serious damage to the pump. Read and heed all warning tags and labels.

Prior to assembly and/or installation, the pump and loose parts are to be inspected for completeness, correctness and cleanliness. During this inspection, all parts are to be thoroughly cleaned and any burrs removed by filing. The pump bowl assembly, including the line shaft coupling, is normally shipped completely assembled. Both the suction and discharge openings should be inspected for damage and for foreign materials. Rotate the shaft by hand, and move in and out to check for end play. Place all parts in an orderly arrangement for convenient assembly.

WARNING

Extreme caution is to be exercised when hoisting components with open lifting lugs. Precautions should be taken to prevent hoisting slings from coming out of the lugs.

WARNING

Never attempt to mount the driver on the discharge head prior to installation of the pump.

WARNING

Never attempt to hoist the entire pump by the driver lifting lugs or eyes. These lifting points are designed only to hoist the weight of the driver, not other attached components.

IMPORTANT

All shafting has been pre-straightened to a tolerance of 0.005" in 10 feet prior to leaving the factory or assembly plant. Care in handling must be taken to insure that the shafting is not bent prior to and during installation.

Foundation

A foundation must be supplied consisting of any material that will provide a permanent, rigid support. This support is to be of sufficient size and depth to fully carry the weight of the pump (full of water) and rigid enough to prevent vibration.

Anchor bolts are to be supplied and set in place by the installing contractor. Anchor bolts of appropriate size, length and configuration are required to adequately secure the discharge head/pedestal to the foundation.

When the pump is to be mounted over a pit on structural steel framing, it should be located as close to the main structure or wall as possible. Cross members are to be used to prevent distortion and vibration of structural mounting frame.

Well and Pit Inspection

Prior to installation and start-up, the well or pit must be cleaned of all loose material and debris. Both the suction and discharge openings should be inspected for damage and for foreign materials.

CAUTION

Reduced performance and possible equipment damage may result from ingestion of foreign material by the pump.

Bowl Assembly**CAUTION**

Turbine pumps are shipped with a shaft retention bolt installed in the suction bell to protect the pump from damaging shaft movement during transit. It is imperative that the retaining bolt be removed, and grease added (if not already packed) to lower bearing cavity. Install the suction bell plug prior to pump installation. Failure to follow these instructions will result in serious damage to the pump. Read and heed all warning tags and labels.

NOTE

Before proceeding, measure and record the pump bowl assembly end play. This information will be needed later.

Shaft projection is defined as the distance from the discharge bowl mounting surface (flange seat for flanged column, thread seat for threaded column) to the end of the pump shaft. Nominal standard shaft projection for model 1100 sizes 6 through 18 is 17-1/2". Since all applicable 1100 bowl assemblies are shipped with the pump shaft bolted in its lower most position, projection is measured with the impellers resting at the bottom of their axial travel.

CAUTION

Always remove the shaft retaining bolt before installing or operating the pump.

Shaft end play is the amount of axial movement available in the pump bowl assembly. After removing the shaft retaining bolt, measure and record the pump bowl end play. This can most easily be accomplished with the bowl assembly in a

horizontal position. Grasp the pump shaft and move the shaft through its maximum axial travel. Consult Table #1 in the Technical Data Section to assure that the distance measured complies with the specifications for your pump model.

A discharge case is included for: a.) single-stage open line shaft bowl assemblies; b.) single or multi-stage oil lubricated enclosed line shaft bowl assemblies; or c.) single or multi-stage water-flushed lubricated enclosed line shaft bowl assemblies.

Discharge cases for open line shaft units are shipped with two pipe plugs installed. Plugs must be left in place for discharge cases used with enclosed line shaft water-flushed and open line shaft units.

CAUTION

Should you receive a bowl assembly for enclosed line shaft oil lubricated construction that has two pipe plugs installed in the discharge case, THESE PIPE PLUGS MUST BE REMOVED PRIOR TO INSTALLATION. Failure to remove the plugs will cause water to enter the enclosing tube and leak out at the discharge head. Bearing failure may result.

Suction Strainer

If a suction strainer is to be used, it is to be either threaded into the suction case or clipped onto the suction bell as required.

Hoisting, Leveling, Grouting & Piping

If your pump was shipped completely assembled, it is now ready to install.

WARNING

The pump is to always be lifted using adequate crane and sling capacity. All applicable safe hoisting practices should be employed.

The pump is to be hoisted by the discharge head. Pumps thirty feet or more in overall length should also be supported at the column midpoint to avoid column/shaft distortion and possible pump damage. The pump is to be lowered onto the anchor bolts and leveled. This can be achieved by applying a good quality machinist's spirit level to the machined motor mounting surface or to the below-grade pump column, if accessible.

After leveling, the base plate is to be grouted in place with a good quality non-shrinking grout. After the grout is fully dry, the base plate is to be nutted solidly in place against the grout bed.

Leveling devices are to be removed or backed off and the pump base plate tightened solidly against the grout bed. All pockets and/or holes left by removal of leveling devices are to be filled with grout.

IMPORTANT

Damaging vibration may result if the base plate is not solidly in contact with the grout bed. Even the highest quality non-shrink grouts contract slightly during drying. All leveling wedges, nuts or jackscrews are to be removed or backed off prior to final torquing of the base plate fasteners. Failure to do so will result in the pump base plate resting on the leveling devices rather than the grout bed.

Piping is to be brought in direct axial alignment with the pump discharge. Flange faces are to fit closely and squarely. The pump discharge is to have no strain imposed upon it by piping misalignment.

Pump Assembly

If the pump has been shipped disassembled, the following instructions are to be employed to assemble the unit vertically in the well or sump.

Determine if the pump to be assembled is Product Lubricated Open Line Shaft, Oil Lube Enclosed Line Shaft or Water Flush Enclosed Line Shaft. Prior to assembly, all components are to be identified and laid out in order of assembly. Standard length (5' or 10') intermediate column, and shaft are interchangeable and can be assembled in any order. However, shorter non-standard column and shaft sections are provided to accomplish the required overall pump length, and must be installed at the top of the pump directly under the discharge head. The top enclosing tube also has longer threads to engage the top tube tension nut.

On threaded column, all column couplings are to be installed on the upper end of the column prior to lifting. This will provide a stop for pipe clamps during the hoisting process.

Product Lubricated Open Lineshaft**Flanged Column**

- A. Using an appropriate hoisting system, lift the bowl assembly into position over the well. Lower the bowl partially into the well. Attach a pipe clamp (see Figure #1) to the upper most bowl directly under the bowl discharge flange. Lower the assembly, allowing it to be supported on the foundation via the pipe clamp.
- B. Lift the first section of pre-assembled column & shaft into position over the suspended bowl assembly (see Figure #2). Care is to be taken not to damage the threads on the pump shaft or line shafts. Clean the threads and lubricate with appropriate thread lubricant.

A line shaft coupling should already be in place on the pump shaft. Thread the line shaft into the coupling.

IMPORTANT

Line shaft threads are left hand. Tighten shafts and couplings securely with pipe wrenches.

Assure that no burrs or foreign matter exists on the coupling or on the shaft threads. The threaded shafts are to butt together solidly and squarely in the center of the coupling. Both shafts are to be equally engaged in the coupling threads. Threads should be exposed on both ends of the coupling.

NOTE

Shafts with replaceable wear sleeves must be positioned to engage line shaft bearings. The presence of any foreign material between the shaft ends will cause shaft misalignment and will result in vibration or accelerated bearing wear.

- C. Hoist the first section of column into position over the assembled line shaft. Lower the column onto the bowl discharge flange. All column joints should be coated with non-hardening gasket sealant such as Loctite PST #567, Permatex No. 2 or equal. Silicon sealants are also permissible. Install bolts and nuts and tighten.

IMPORTANT

Measure the shaft projection. It should conform to the shaft projection measurement taken and recorded previously on the bowl assembly.

- D. The line shaft is to project out beyond the end of the installed column. Install the bearing retainer assembly over the shaft projection. Seat the retainer OD in the column flange counterbore.

NOTE

Coat the column counterbore with sealant prior to a retainer installation.

NOTE

Bronze line shaft bearings are to be lubricated with grease prior to installation. Rubber line shaft bearings should NOT be lubricated. Lubrication of rubber bearings may cause distortion or swelling.

- E. Lift the column/bowl assembly slightly and remove the pipe clamp from the bowl. Lower the assembly and reinstall the pipe clamp below the upper column flange. Lower the assembly so the pipe clamp suspends the assembly on the foundation.
- F. Install the next shaft and column segment as previously instructed assuring that its lower flange counterbore engages the top of the bearing retainer OD. Coat the column counterbores with sealant prior to installation.
- Install bolts and nuts and tighten. A slight gap will remain between the two column flanges. This condition allows the bearing retainer to be clamped securely between the flanges.
- G. Continue subsequent shaft and column assembly until complete. Continue to measure the shaft projection after assembly of each shaft/column section.

NOTE

Standard shaft and column lengths are 10 feet. Non-standard lengths of shafts and column may be used to accomplish the required overall pump length. Non-standard shaft/column sections will always be assembled at the top of the pump, directly under the discharge head. The shaft segment which protrudes through the packing box will always have a replaceable wear sleeve unless otherwise specified and submitted.

Assembly procedure for underground discharge (U.G.D.) units closely parallels that of standard pumps with above ground discharge heads. Always refer to the Layne/Verti-Line submittal drawings and setting plan to determine the proper location of discharge elbow centerline.

If the packing box of the U.G.D. pump is lubricated by the pumped media, it will be necessary to provide an air release valve in the top column. This will prevent air from becoming trapped in the column above the discharge elbow, therefore allowing the media to lubricate the packing box bushing and packing. If the pump's total dynamic head is not sufficient to raise the media to the altitude of the packing box, an alternate method of lubrication must be provided (i.e., grease lubrication).

- H. For ease of installation, remove the packing box if shipped assembled to the discharge head.
- I. Install column flange gasket (when used) and secure the discharge head to the last column flange. When attaching the column to the discharge head, make sure the register fit is fully engaging the head.
- J. After attaching the column to the discharge head remove the column clamp, and lower the unit to the foundation and tighten mounting bolts. Check the shaft to see if it is centered in the packing box opening in the head. If

the shaft is not centered, it could be an indication of a bent shaft, column not seated properly, or the unit is not properly plumbed. Any or all of these problems must be corrected before proceeding with the installation of the unit.

- K. Apply lubricant to the packing box bushing and install the packing box on the discharge head.
- L. Install the packing and glands into the packing box. Install gland bolts and nuts. Allow the gland nuts remain loose. Packing adjustment will be performed later with the pump operating. If a mechanical seal is employed, refer to the Mechanical Seal section of this manual.

Threaded Column

1. Using an appropriate hoisting system, lift the bowl assembly into position over the well. Lower the bowl partially into the well. Attach a pipe clamp (see Figure #1) to the upper most bowl directly under the bowl threads. Lower the assembly, allowing it to be supported on the foundation via the pipe clamp.
2. Lift the first section of pre-assembled column & shaft into position over the suspended bowl assembly (see Figure #2). Care is to be taken not to damage the threads on the pump shaft or line shafts. Clean the threads and lubricate with appropriate thread lubricant.

A line shaft coupling should already be in place on the pump shaft. Thread the line shaft into the coupling.

IMPORTANT

Line shaft threads are left hand. Tighten shafts and couplings securely with pipe wrenches.

Assure that no burrs or foreign matter exists on the coupling or on the shaft threads. The threaded shafts are to butt together solidly and squarely in the center of the coupling. Both shafts are to be equally engaged in the coupling threads. Threads should be exposed on both ends of the coupling.

NOTE

Shafts with replaceable wear sleeves must be positioned to engage line shaft bearings. The presence of any foreign material between the shaft ends will cause shaft misalignment and will result in vibration or accelerated bearing wear.

IMPORTANT

Assure that no burrs or foreign matter exists on the column coupling threads or on the column threads prior to assembly. All joints are to be coated with sealant prior to assembly. The column sections should butt together solidly and squarely in the middle of the column coupling. Secure each joint firmly with appropriate wrenches. **ALL COLUMN THREADS ARE RIGHT HAND ROTATION.**

3. Lower the column and thread it into the bowl assembly until it solidly and squarely butts together with the bowl, tightening with appropriate wrenches.
4. Lift the column/bowl assembly slightly and remove the pipe clamp from the bowl. Lower the assembly and reinstall the pipe clamp below the upper column threads. Lower the assembly so the pipe clamp suspends the assembly on the foundation.

The line shaft is to project out beyond the end of the installed column.

IMPORTANT

Measure the shaft projection. It should conform to the shaft projection measurement taken and recorded previously on the bowl assembly.

NOTE

Coat the column counterbore with sealant prior to a retainer installation.

NOTE

Bronze line shaft bearings are to be lubricated with grease prior to installation. Rubber line shaft bearings should NOT be lubricated. Lubrication of rubber bearings may cause distortion or swelling.

5. Slide the bearing retainer with bearing over the shaft projection and lower into the column coupling. Install the shaft coupling and next section of shaft/column assembly as previously outlined.
6. Continue subsequent shaft and column assembly until complete. Continue to measure the shaft projection after assembly of each shaft/column section.

NOTE

Standard shaft and column lengths are 10 feet. Non-standard lengths of shafts and column may be used to accomplish the required overall pump length. Non-standard shaft/column sections will always be assembled at the top of the pump, directly under the discharge head. The shaft segment which protrudes through the packing box will always have a replaceable wear sleeve unless otherwise specified and submitted.

Assembly procedure for underground discharge (U.G.D.) units closely parallels that of standard pumps with above ground discharge heads. Always refer to the Layne/Verti-Line submittal drawings and setting plan to determine the proper location of discharge elbow centerline.

If the packing box of the U.G.D. pump is lubricated by the pumped media, it will be necessary to provide an air release valve in the top column. This will prevent air from becoming trapped in the column above the discharge elbow, therefore allowing the media to lubricate the packing box bushing and packing. If the pump's total dynamic head is not sufficient to raise the media to the altitude of the packing box, an alternate method of lubrication must be provided, i.e., grease lubrication.

7. For ease of installation, remove the packing box if shipped assembled to the discharge head.
8. Thread the top column adapter flange onto the top column and tighten with appropriate wrenches. Install column flange gasket and secure the discharge head to the column adapter flange. When attaching the column to the discharge head, make sure the register fit is fully engaging the head and the flange is timed with the pipe tapped hole in the discharge head.
9. After attaching the column to the discharge head, remove the column clamp and lower the unit to the foundation. Tighten mounting bolts. Check the shaft to see if it is centered in the packing box opening in the head. If the shaft is not centered, it could be an indication of a bent shaft, column not seated properly, or the unit is not properly plumbed. Any or all of these problems must be corrected before proceeding with the installation of the unit.

10. Apply lubricant to the packing box bushing and install the packing box on the discharge head.
11. Install the packing and glands into the packing box. Install gland bolts and nuts. Allow the gland nuts remain loose. Packing adjustment will be performed later with the pump operating. If a mechanical seal is employed, refer to the Mechanical Seal section of this manual.

Oil Lube Enclosed Line Shaft

Flanged Column

1. Using an appropriate hoisting system, lift the pre-assembled bowl assembly and position it above the well. Lower the bowl assembly partially into the well and attach a pipe clamp (see Figure #1) to the upper most bowl directly under the bowl discharge flange. Lower the assembly, allowing it to be suspended on the foundation via the pipe clamp.
2. Before proceeding with assembly, lay out all line shaft, enclosing tube, column and connectors. Inspect and identify all items and arrange them in the order in which they will be assembled. Oversized diameter enclosing tube sections (if used) must be installed at the bottom of the assembly, directly above the pump discharge bowl. When oversized tube sections are used, special stepped connector bearings are provided in order to adapt them to the remaining.

Pre-assemble matching sets of shaft, enclosing tube and column by sliding them inside each other and attaching connectors and couplings. This will allow each set of column/enclosing tube/shaft to be hoisted into place and assembled as demonstrated in Figure #3.

Non-standard lengths of column, enclosing tube and line shafting must be assembled at the top of the pump as previously outlined.

Using an appropriate hoisting system, lift the shaft/tube/column assembly and position it above the suspended bowl. Slide the lower end of the shaft out of the enclosing tube about one foot. Refer to Figure #4 for lifting of this assembly.

3. Lower the shaft/tube/column assembly into position. A line shaft coupling is to already be in place on the pump shaft. Assure that the threaded shafts and coupling are clean and free of burrs. Lubricate threads with light oil. Thread the shafts into the coupling so that both shafts engage the coupling equally. The shafts should butt together solidly in the center of the coupling. Threads should be exposed on both ends of the coupling. Assure that no foreign matter exists between the shaft ends. Such a condition will cause shaft misalignment and will result in vibration and accelerated bearing wear.

IMPORTANT

Line shaft threads and enclosing tube threads are left hand rotation. Tighten shafts, enclosing tubes and couplings securely with pipe wrenches.

4. Assure that all enclosing tube threads and connector bearing threads are clean and free of burrs. Coat connector bearing threads with a sealant such as Loctite PST #567, Permatex No. 2 non-hardening gasket sealant prior to assembly. Silicone sealants are also permissible. This step is very important in preventing entry of the pressurized pumped media into the enclosing tube. Thread the enclosing tube onto the connector bearing and secure with chain wrenches.

5. Clean all coating or foreign materials from the column flange faces prior to assembly. Lower the shaft/tube/column assembly into position and coat the flange faces with sealant. Assure that the flange faces engage squarely and that all bolt holes align. Install bolts and nuts and tighten.
6. Lift the column and bowl assembly slightly. Remove the pipe clamp from the bowl and lower the assembly into the well. Reinstall the pipe clamp on the upper end of the column directly below the upper flange. Lower the assembly until the pipe clamp supports the assembly on the foundation.

IMPORTANT

Measure the shaft projection. It should conform to the shaft projection measurement taken and recorded previously on the bowl assembly.

7. Repeat the above steps until complete. Continue to measure the shaft projection after assembly of each shaft/tube/-column section. Before installing the discharge head, pre-lubricate the connector bearings by pouring oil down the enclosing tube. Approximately one pint of oil should be added for every 20 ft. of pump length.

NOTE

Although standard column length is 10 feet, some non-standard lengths of column, enclosing tube and shaft may be required to accomplish the specified overall length of the pump. These non-standard lengths should be installed at the top of the column, directly under the discharge head.

Assembly procedure for underground discharge (U.G.D.) units closely parallels that of standard pumps with above ground discharge heads. Always refer to the Layne/Verti-Line submittal drawings and setting plan to determine the proper location of discharge elbow centerline.

8. Install column flange gasket (when used) to the upper column flange and secure to the discharge head being sure it is timed with the pipe tap hole of the discharge head.
9. Coat both sides of the copper gasket and the tension nut threads with sealant prior to installation. Install the bronze top tube tension nut gasket onto the top tube tension nut.
10. Install the top tube tension nut over the projecting line shaft and slide into position in the discharge head. Remembering that the tension nut threads are left handed, thread it into the top enclosing tube. The threads should engage the tube smoothly and allow the washer and nut to seat squarely in the counterbore of the discharge head. Torque the top tube tension nut (refer to Table #2).

Threaded Column

Install column couplings the upper end of the column prior to lifting. This will provide a stop for pipe clamps during the hoisting process.

1. Using an appropriate hoisting system, lift the pre-assembled bowl assembly and position it above the well. Lower the bowl assembly partially into the well and attach a pipe clamp (see Figure #1) to the upper most bowl directly under the bowl discharge flange. Lower the assembly, allowing it to be suspended on the foundation via the pipe clamp.

2. Before proceeding with assembly, lay out all line shaft, enclosing tube, column and connectors. Inspect and identify all items and arrange them in the order in which they will be assembled. Oversized diameter enclosing tube sections (if used) must be installed at the bottom of the assembly, directly above the pump discharge bowl. When oversized tube sections are used, special stepped connector bearings are provided in order to adapt them to the remaining standard diameter enclosing tube sections.

Pre-assemble matching sets of shaft, enclosing tube and column by sliding them inside each other and attaching connectors and couplings. This will allow each set of column/enclosing tube/shaft to be hoisted into place and assembled as demonstrated in Figure #3.

Non-standard lengths of column, enclosing tube and line shafting must be assembled at the top of the pump as previously outlined.

Using an appropriate hoisting system, lift the shaft/tube/column assembly and position it above the suspended bowl. Slide the lower end of the shaft out of the enclosing tube about one foot.

3. Lower the shaft/tube/column assembly into position. A line shaft coupling is to already be in place on the pump shaft. Assure that the threaded shafts and coupling are clean and free of burrs. Lubricate threads with light oil. Thread the shafts into the coupling so that both shafts engage the coupling equally. The shafts should butt together solidly in the center of the coupling. Threads should be exposed on both ends of the coupling. Assure that no foreign matter exists between the shaft ends. Such a condition will cause shaft misalignment and will result in vibration and accelerated bearing wear.

IMPORTANT

Line shaft threads and enclosing tube threads are left hand rotation. Tighten shafts, enclosing tubes and couplings securely with pipe wrenches.

4. Assure that all enclosing tube threads and connector bearing threads are clean and free of burrs. Coat connector bearing threads with a sealant such as Loctite PST #567, Permatex No. 2 non-hardening gasket sealant prior to assembly. Silicone sealants are also permissible. This step is very important in preventing entry of the pressurized pumped media into the enclosing tube. Thread the enclosing tube onto the connector bearing and secure with chain wrenches.

IMPORTANT

Assure that no burrs or foreign matter exists on the column coupling threads or on the column threads prior to assembly. All joints are to be coated with sealant prior to assembly. The column sections should butt together solidly and squarely in the middle of the column coupling. Secure each joint firmly with appropriate wrenches. **ALL COLUMN THREADS ARE RIGHT HAND ROTATION.**

5. Lower the column and thread it into the bowl assembly until it solidly butts together with the bowl, tightening it firmly with pipe wrenches.

The line shaft and enclosing tube is to project out beyond the end of the installed column.

6. Lift the column and bowl assembly slightly. Remove the pipe clamp from the bowl and lower the assembly into the well. Reinstall the pipe clamp on the upper end of the column directly below the upper column threads. Lower the assembly until the pipe clamp supports the assembly on the foundation.

IMPORTANT

Measure the shaft projection. It should conform to the shaft projection measurement taken and recorded previously on the bowl assembly.

7. Repeat the above steps until complete. Continue to measure the shaft projection after assembly of each shaft/tube/column section. Before installing the discharge head, pre-lubricate the connector bearings by pouring oil down the enclosing tube. Approximately one pint of oil should be added for every 20 ft. of pump length.

NOTE

Standard shaft and column lengths are 10 feet. Non-standard lengths of shafts and column may be used to accomplish the required overall pump length. Non-standard shaft/column sections will always be assembled at the top of the pump, directly under the discharge head.

Assembly procedure for underground discharge units closely parallels that of standard pumps with above ground discharge heads. Always refer to the Layne/Verti-Line submittal drawings and setting plans.

8. Thread the top column adapter flange onto the top column and tighten with appropriate wrenches. Install column flange gasket and secure the discharge head to the column adapter flange. When attaching the column to the discharge head, make sure the flange is timed with the pipe tapped hole in the discharge head.
9. Install the bronze top tube tension nut washer onto the top tube tension nut. Coat both sides of the copper gasket and the tension nut threads with sealant prior to installation. Install the bronze top tube tension nut gasket onto the top tube tension nut.

10. Install the top tube tension nut over the projecting line shaft and slide into position in the discharge head. Remembering that the tension nut threads are left handed, thread it into the top enclosing tube. The threads should engage the tube smoothly and allow the washer and nut to seat squarely in the counterbore of the discharge head. Torque the top tube tension nut (refer to the technical data page for correct torque values).

Water Flush Enclosed Line Shaft

Flanged Column

1. Using an appropriate hoisting system, lift the pre-assembled bowl assembly and position it above the well. Lower the bowl assembly partially into the well and attach a pipe clamp (see Figure #1) to the upper most bowl directly under the bowl discharge flange. Lower the assembly, allowing it to be suspended on the foundation via the pipe clamp.
2. Before proceeding with assembly, lay out all line shaft, enclosing tube, column and connectors. Inspect and identify all items and arrange them in the order in which they will be assembled. Oversized diameter enclosing tube sections (if used) must be installed at the bottom of the assembly, directly above the pump discharge bowl. When oversized tube sections are used, special stepped connector bearings are provided in order to adapt them to the remaining standard diameter enclosing tube sections.

Pre-assemble matching sets of shaft, enclosing tube and column by sliding them inside each other and attaching connectors and couplings. This will allow each set of column/enclosing tube/shaft to be hoisted into place and assembled.

Non-standard lengths of column, enclosing tube and line shafting must be assembled at the top of the pump as previously outlined.

3. Lower the shaft/tube/column assembly into position. A line shaft coupling is to already be in place on the pump shaft. Assure that the threaded shafts and coupling are clean and free of burrs. Lubricate threads with light oil. Thread the shafts into the coupling so that both shafts engage the coupling equally. The shafts should butt together solidly in the center of the coupling. Threads should be exposed on both ends of the coupling. Assure that no foreign matter exists between the shaft ends. Such a condition will cause shaft misalignment and will result in vibration and accelerated bearing wear.

IMPORTANT

Line shaft threads and enclosing tube threads are left hand rotation. Tighten shafts, enclosing tubes and couplings securely with pipe wrenches.

4. Assure that all enclosing tube threads and connector bearing threads are clean and free of burrs. Coat connector bearing threads with a sealant such as Loctite PST #567, Permatex No. 2 non-hardening gasket sealant prior to assembly. Silicone sealants are also permissible. This step is very important in preventing entry of the pressurized pumped media into the enclosing tube. Thread the enclosing tube onto the connector bearing and secure with chain wrenches.
5. Clean all coating or foreign materials from the column flange faces prior to assembly. Lower the shaft/tube/column assembly into position and coat the flange faces with sealant. Assure that the flange faces engage squarely and that all bolt holes align. Install bolts and nuts and tighten.

6. Lift the column and bowl assembly slightly. Remove the pipe clamp from the bowl and lower the assembly into the well. Reinstall the pipe clamp on the upper end of the column directly below the upper flange. Lower the assembly until the pipe clamp supports the assembly on the foundation.

IMPORTANT

Measure the shaft projection. It should conform to the shaft projection measurement taken and recorded previously on the bowl assembly.

7. Repeat the above steps until complete. Continue to measure the shaft projection after assembly of each shaft/tube/-column section.

NOTE

Although standard column length is 10 feet, some non-standard lengths of column, enclosing tube and shaft may be required to accomplish the specified overall length of the pump. These non-standard lengths should be installed at the top of the column, directly under the discharge head.

NOTE

The segment of the line shaft which protrudes through the combination top tube tension nut/packing box will always have a replaceable wear sleeve. This shaft must be installed so that the sleeve engages the top tube tension nut bushing.

Assembly procedure for underground discharge (U.G.D.) units closely parallels that of standard pumps with above ground discharge heads. Always refer to the Layne/Verti-Line submittal drawings and setting plans to determine the proper location of discharge elbow centerline.

8. Install column flange gasket (when used) to the upper column flange and secure to the discharge head being sure it is timed with the pipe tap hole of the discharge head.
9. Coat both sides of the copper gasket and the tension nut threads with sealant prior to installation. Install the bronze top tube tension nut gasket onto the top tube tension nut.
10. Install the combination top tube tension nut/packing box over the projecting line shaft and slide into position in the discharge head. Remembering that the tension nut threads are left handed thread it into the top enclosing tube. The threads should engage the tube smoothly and allow the washer and nut to seat squarely in the counter bore of the discharge head. Torque the combination top tube tension nut/packing box (refer to Table #3).
11. Install the packing and glands into the packing box. Install the gland bolts and nuts. Allow the gland nuts to remain loose. Packing adjustment will be performed late with pump operating. If a mechanical seal is employed, refer to the Mechanical Seal section of this manual.

Threaded Column

1. Using an appropriate hoisting system, lift the pre-assembled bowl assembly and position it above the well. Lower the bowl assembly partially into the well and attach a pipe clamp (see Figure #1) to the upper most bowl directly under the bowl discharge flange. Lower the assembly, allowing it to be suspended on the foundation via the pipe clamp.
2. Before proceeding with assembly, lay out all line shaft, enclosing tube, column and connectors. Inspect and identify all items and arrange them in the order in which they will be assembled. Oversized diameter enclosing tube sections (if used) must be installed at the bottom of the assembly, directly above the pump discharge bowl. When oversized tube sections are used, special stepped connector bearings are provided in order to adapt them to the remaining standard diameter enclosing tube sections.

Pre-assemble matching sets of shaft, enclosing tube and column by sliding them inside each other and attaching connectors and couplings. This will allow each set of column/enclosing tube/shaft to be hoisted into place and assembled as demonstrated in Figure #3.

Non-standard lengths of column, enclosing tube and line shafting must be assembled at the top of the pump as previously outlined.

3. Lower the shaft/tube/column assembly into position. A line shaft coupling is to already be in place on the pump shaft. Assure that the threaded shafts and coupling are clean and free of burrs. Lubricate threads with light oil. Thread the shafts into the coupling so that both shafts engage the coupling equally. The shafts should butt together solidly in the center of the coupling. Threads should be exposed on both ends of the coupling. Assure that no foreign matter exists between the shaft ends. Such a

condition will cause shaft misalignment and will result in vibration and accelerated bearing wear.

4. Assure that all enclosing tube threads and connector bearing threads are clean and free of burrs. Coat connector bearing threads with a sealant such as Loctite PST #567, Permatex No. 2 non-hardening gasket sealant prior to assembly. Silicone sealants are also permissible. This step is very important in preventing entry of the pressurized pumped media into the enclosing tube. Thread the enclosing tube onto the connector bearing and secure with chain wrenches.

IMPORTANT

Assure that no burrs or foreign matter exists on the column coupling threads or on the column threads prior to assembly. All joints are to be coated with sealant prior to assembly. The column sections should butt together solidly and squarely in the middle of the column coupling. Secure each joint firmly with appropriate wrenches. **ALL COLUMN THREADS ARE RIGHT HAND ROTATION.**

5. Lower the column and thread it into the bowl assembly until it solidly and squarely butts together with the bowl, tightening it firmly with appropriate wrenches.

The line shaft and enclosing tube is to project out beyond the end of the installed column.

6. Lift the column and bowl assembly slightly. Remove the pipe clamp from the bowl and lower the assembly into the well. Reinstall the pipe clamp below the upper column threads. Lower the assembly until the pipe clamp supports the assembly on the foundation.

IMPORTANT

Measure the shaft projection. It should conform to the shaft projection measurement taken and recorded previously on the bowl assembly.

7. Repeat the above steps until complete. Continue to measure the shaft projection after assembly of each shaft/tube/-column section.

NOTE

Standard shaft and column lengths are 10 feet. Non-standard lengths of shafts and column may be used to accomplish the required overall pump length. Non-standard shaft/column sections will always be assembled at the top of the pump, directly under the discharge head.

NOTE

The segment of the line shaft which protrudes through the combination top tube tension nut/packing box will always have a replaceable wear sleeve. This shaft must be installed so that the sleeve engages the top tube tension nut bushing.

Assembly procedure for underground discharge units closely parallels that of standard pumps with above ground discharge heads. Always refer to the Layne/Verti-Line submittal drawings and setting plans.

Assembly procedure for underground discharge (U.G.D.) units closely parallels that of standard pumps with above ground discharge heads. Always refer to the Layne/Verti-Line submittal drawings and setting plans to determine the proper location of discharge elbow centerline.

8. Thread the top column adapter flange onto the top column and tighten with appropriate wrenches. Install column flange gasket and secure the discharge head to the column adapter flange.

When attaching the column to the discharge head, make sure the flange is timed with the pipe tapped hole in the discharge head.

9. Install the bronze top tube tension nut washer onto the top tube tension nut. Coat both sides of the copper gasket and the tension nut threads with sealant prior to installation. Install the bronze top tube tension nut gasket onto the top tube tension nut.
10. Install the combination top tube tension nut/packing box over the projecting line shaft and slide into position in the discharge head. Remembering that the tension nut threads are left handed, thread it into the top enclosing tube. The threads should engage the tube smoothly and allow the washer and nut to seat squarely in the counter bore of the discharge head. Torque the combination top tube tension nut/packing box (refer to Table #3).
12. Install the packing and glands into the packing box. Install the gland bolts and nuts. Allow the gland nuts to remain loose. Packing adjustment will be performed late with pump operating. If a mechanical seal is employed, refer to the Mechanical Seal section of this manual.

Driver Installation**IMPORTANT**

Read and understand the driver manufacturer's manual before proceeding. Determine if the driver is to be installed is a vertical hollow shaft electric motor, a solid shaft motor or a right angle gear. Refer to the appropriate instructions.

VERTICAL HOLLOW SHAFT DRIVERS

General

Hollow shaft drivers provide a hollow tube through the rotor. The pump shaft passes through the tube and attaches at the top of the driver. Most turbine pump designs provide a shaft coupling above the packing box or tube tension nut. This allows the motor to be set in place and the top section of shaft installed later, through the top of the driver. Other shaft/head designs have no such coupling and require that the motor be lowered over the projecting top shaft.

CAUTION

Care should be taken to avoid motor/shaft contact during this process as a bent top shaft could result.

Register fits on the bottom of the driver base and on the top of the discharge head (motor pedestal) will facilitate approximate driver positioning. The fits are generally loose enough to accommodate the additional movement required for precision alignment. After precision alignment is achieved, the driver is permanently held in position by the clamping force of the mounting bolts. Doweling or pinning of the driver is not required, but may be implemented at the owner's option.

- A. Before installation, remove the driver top cover. Remove the driver clutch coupling (or non-reverse ratchet if so equipped). This will facilitate top shaft installation and rotation check.
- B. Using an appropriate hoisting system, lift the driver over the discharge head mounting surface and carefully lower into position. Engage the driver base over the register fit of the mounting surface.
- C. Bolt the driver down. If an electric motor is used, now is the time to connect it to the electrical source and to verify correct rotation. If a right angle gear is used proceed to step 4.

DANGER

Electrical motors must be installed and operated only by qualified, trained electrical technicians. Consult the motor manufacturer or the motor manual to assure that all installation and safety procedures are fully understood and implemented. Always lock out all controls and or supplies and verify driver cannot be started before installing or servicing electrical apparatus.

CAUTION

Oil lubricated drivers and right angle gears are shipped dry and require an initial fill of the manufacturer's recommended lubricant prior to bump-start.

With non-reverse ratchets (if so equipped) removed or disabled, "bump" the motor for rotation. This is generally accomplished on three-phase motors by engaging and **immediately** disengaging the power switch. It is seldom necessary to engage the power source for more than one second to determine motor rotation.

Note the direction of motor rotation. If the motor rotates counter clockwise as viewed from the top, the rotation is correct and installation may proceed. If the motor rotates clockwise as viewed from the top, reverse any two of the three power leads and motor rotation will be reversed.

CAUTION

Line shaft threads are left hand rotation. Operation of the pump in a clockwise (as viewed from the top) direction will cause the line shaft couplings to unthread, causing serious damage to the pump.

CAUTION

Assure that no burrs or foreign matter exists on the shaft threads.

- D. Install the pump's driver top shaft through the top of the driver and tighten into the line shaft coupling. Make sure that the top shaft is centered in the tube.
- E. Install the driver coupling and/or non-reverse ratchet. Install the gib key (supplied with the driver) into the driver/shaft keyway. The key should be a close slip fit in the keyways. It may be necessary to deburr or file the key to achieve the proper fit. **Never** drive or wedge the key into an overly tight keyway.
- F. Install the top shaft adjusting nut. The adjusting nut will be used to lift the shaft/impeller assembly in order to achieve proper impeller clearance. Adjusting nut threads are right hand rotation.

NOTE

Before installation of the nut, the weight of the shaft/impeller assembly rests on the bottom of the pump bowls. This condition makes the shaft almost impossible to rotate until the nut is installed and the shaft/impellers are raised off the bottom of the bowls. In running position, the shaft, impellers and hydraulic down thrust are supported by the driver thrust bearing.

- G. Tighten the nut on the shaft until the impellers are raised very slightly off the bowl bottoms. This will be evident when resistance to shaft rotation disappears as the impellers are lifted off the bottom.
- H. With the impellers very slightly off the bottom, add the additional nut turns required to achieve the specified clearance. Determine the correct impeller setting from the Technical Data page found in the drawing section of this manual.

NOTE

Extremely long pumps (deep settings) may require additional nut adjustment to accommodate line shaft stretch. Extra adjustment is not generally required for pumps less than 150 feet in length. For pumps over 150 feet long, consult the factory for instructions.

- I. After impeller adjustment, place the adjusting nut lock screw through the nut and thread into the driver clutch coupling and secure. If the nut must be rotated to align with the clutch coupling hole, always move to the next higher adjustment position.
- J. Replace the driver cover.
- K. Refer to the driver manual to assure that all lubrication instructions have been followed completely.
- L. Consult the driver manufacturer's manual to insure that all safety procedures are completely understood and implemented prior to operation.

IMPORTANT

Grease lubricated drivers are shipped pre-lubricated. Oil lubricated drivers and right angle gears driver are shipped dry and require an initial fill of the manufacturer's recommended lubricant prior to startup. See driver manufacturer's manual for lubrication specifications. Initial start-up lubricants are NOT supplied by the manufacturer.

VERTICAL SOLID SHAFT DRIVERS

General

Solid shaft drivers have a vertical main shaft projecting from the bottom of the driver base. The shaft projection has a vertical keyway to transmit torque and an annual groove to suspend the pump shaft/impeller assembly. Solid shaft drivers require the use of rigid adjustable couplings to facilitate pump impeller adjustment.

Register fits on the bottom of the driver base and on the top of the discharge head (motor pedestal) will facilitate approximate driver positioning. The fits are generally loose enough to accommodate the additional movement required for precision alignment. After precision alignment is achieved, the driver is permanently held in position by the clamping force of the mounting bolts. Doweling or pinning of the driver is not required, but may be implemented at the owner's option.

Solid shaft drivers have a vertical main shaft projecting from the bottom of the driver base. The shaft projection has a vertical keyway to transmit torque and an annual groove to suspend the pump shaft/impeller assembly. Solid shaft drivers require the use of rigid adjustable couplings to facilitate pump impeller adjustment.

Register fits on the bottom of the driver base and on the top of the discharge head (motor pedestal) will facilitate approximate driver positioning. The fits are generally loose enough to accommodate the additional movement required for precision alignment. After precision alignment is achieved, the driver is permanently held in position by the clamping force of the mounting bolts. Doweling or pinning of the driver is not required, but may be implemented at the owner's option.

Style II Coupling

CAUTION

Before installing the driver, read and understand the driver manufacturer's instruction manual.

DANGER

Electric motors must be installed and operated only by qualified, trained electrical technicians. Consult the motor manufacturer or the motor manual to assure that all installation and operation safety procedures are fully understood and implemented. Always lock out all controls and/or power supplies before installing or servicing.

1. Check both driver and pump shafts for burrs or dirt, cleaning as necessary. Also check the coupling parts for burrs and dirt, cleaning as required. If force is required to position the couplings on the shafts, non-metallic dead blow hammers should be used to prevent damage to the machined surfaces.
2. Install the coupling hubs on the driver shaft and top shaft prior to installing the driver according to the following procedure:

NOTE

It is generally most convenient to install the driver coupling hub on the driver shaft before hoisting the driver into position.

- A. Insert the square key into the driver shaft keyway and slide the driver coupling hub onto the driver shaft until the circular keyseat is exposed. Install the thrust rings.
- B. Install a dowel pin into the hole provided in the pump coupling hub. Drive the pin through the coupling hub until it protrudes slightly into the coupling keyway. The purpose of this pin is to prevent the key from falling

out of the hub until the setscrew has been secured. Slide pump coupling half hub over top shaft threads.

- C. Align the keyway in the shaft with the keyway in the coupling hub and insert the key.
- D. Thread the coupling adjusting nut onto the top line shaft.
- E. Using an appropriate hoisting system, lift the driver over the discharge head mounting surface and carefully lower into position. Engage the base over the register fit of the mounting surface. Temporarily bolt the driver down. If an electric motor is used, now is the time to connect to the electrical source per manufacturer's instructions and verify correct rotation. If a right angle gear is used proceed to step 4.

DANGER

Make sure the main power source is locked off before any electrical connections are made and verify driver can not be started. After the start has been performed, again lock off the main power source to guard against accidental starting and electrical shock.

CAUTION

Oil lubricated drivers and right angle gears are shipped dry and require an initial fill of the manufacturer's recommended lubricant prior to bump-start.

WARNING

Make sure all loose coupling parts are off the motor half coupling, and that no part of one coupling half will contact the other half during the bump start, otherwise personal injury could occur.

WARNING

Make sure the protective guard is in place on the discharge head before the bump start is done. Do not operate this machine, even to check rotation, without protective guards in place.

3. With non-reverse ratchets (if so equipped) removed or disabled, "bump" the motor for rotation. Bump start is generally accomplished on three-phase motors by engaging and immediately disengaging the power switch. It is seldom necessary to engage the power source for more than one second to determine motor rotation.

Note the direction of motor rotation. If the motor rotates counter clockwise as viewed from the top, the rotation is correct and installation may proceed. If the motor rotates clockwise as viewed from the top, reverse any two of the three power leads and motor rotation will be reversed.

CAUTION

Operation of the pump in a clockwise (as viewed from the top) direction will cause the line shaft couplings to unthread, causing serious damage to the pump.

4. Impeller adjustment is required to achieve the preferred running position of the impeller within the pump bowl. Also, the impeller must not rub on the bowl seat.

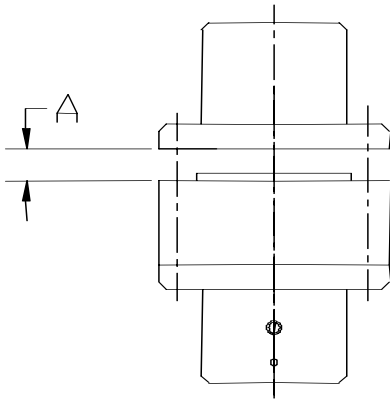


Figure A
Style II Coupling

- A. Determine the correct impeller position from the Technical Data page found in drawing section of this manual.
- B. Thread the adjusting nut upwards toward the driver half coupling until the correct amount of gap "A" is reached (refer to the above illustration).
- C. Adjust to the position that bolt holes line up and insert coupling bolts. Torque to the values as shown the coupling dimension and technical data page in the drawing section of this manual. Install the setscrew in the pump coupling hub and secure.
- D. Install protective guards.

WARNING

Make sure the protective guard is in place on the discharge head before operating the pump.

NOTE

Extremely long pumps (deep settings) may require additional nut adjustment to accommodate line shaft stretch. Extra adjustment is not generally required for pumps less than 150 feet in length. For pumps over 150 feet long, consult the factory for instructions.

Refer to the driver manual to assure that all lubrication instructions have been followed completely.

Consult the driver manufacturer's manual to assure that all safety procedures are completely understood and implemented prior to operation.

CAUTION

Grease lubricated drivers are shipped pre-lubricated. Oil lubricated drivers and right angle gears are shipped dry and require an initial fill of the manufacturer's recommended lubricant prior to start-up. See driver manufacturer's manual for lubrication specifications. Initial start-up lubricants are NOT supplied by the manufacturer.

Style IV Coupling

CAUTION

Before installing the driver, read and understand the driver manufacturer's instruction manual.

DANGER

Electric motors must be installed and operated only by qualified, trained electrical technicians. Consult the motor manufacturer or the motor manual to assure that all installation and operation safety procedures are fully understood and implemented. Always lock out all controls and/or power supplies before installing or servicing.

- A. Check both driver and pump shafts for burrs or dirt, cleaning as necessary. Also check the coupling parts for burrs and dirt, cleaning as required. If force is required to position the couplings on the shafts, non-metallic dead blow hammers should be used to prevent damage to the machined surfaces.

- B. Install the coupling hubs on the driver shaft and top shaft prior to installing the driver according to the following procedure:

NOTE

It is generally most convenient to install the driver coupling hub on the driver shaft before hoisting the driver into position.

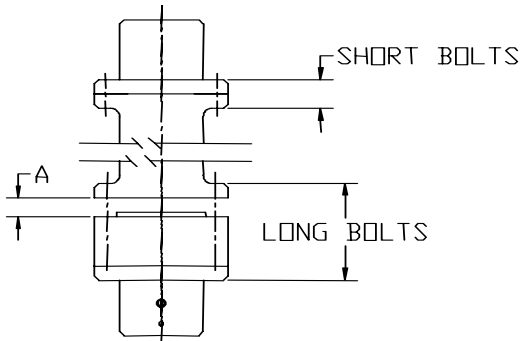


Figure B
Style IV Adjustable Coupling

1. Insert the square key into the driver shaft keyway and slide the driver coupling hub onto the driver shaft until the circular keyseat is exposed. Install the thrust rings. When a spacer is used, pilot the spacer in to the driver hub and secure with the short bolts.
2. Install a dowel pin into the hole provided in the pump coupling hub. Drive the pin through the coupling hub until it protrudes slightly into the coupling keyway. The purpose of this pin is to prevent the key from falling out of the hub until the setscrew has been secured. Slide pump coupling half hub over top shaft threads.
3. Align the keyway in the shaft with the keyway in the coupling hub and insert the key.
4. Thread the coupling adjusting nut onto the top line shaft.
5. Using an appropriate hoisting system, lift the driver over the discharge head

mounting surface and carefully lower into position. Engage the base over the register fit of the mounting surface. Temporarily bolt the driver down. If an electric motor is used, now is the time to connect to the electrical source per manufacturer's instructions and verify correct rotation. If a right angle gear is used proceed to step 4.

DANGER

Make sure the main power source is locked off before any electrical connections are made and verify driver cannot be started. After the start has been performed, again lock off the main power source to guard against accidental starting and electrical shock.

CAUTION

Oil lubricated drivers and right angle gears are shipped dry and require an initial fill of the manufacturer's recommended lubricant prior to bump-start.

WARNING

Make sure all loose coupling parts are off the motor half coupling, and that no part of one coupling half will contact the other half during the bump start, otherwise personal injury could occur.

WARNING

Make sure the protective guard is in place on the discharge head before the bump start is done. Do not operate this machine, even to check rotation, without protective guards in place.

- C. With non-reverse ratchets (if so equipped) removed or disabled, "bump" the motor for rotation. Bump start is generally accomplished on three-phase motors by engaging and immediately disengaging the power switch. It is

seldom necessary to engage the power source for more than one second to determine motor rotation.

Note the direction of motor rotation. If the motor rotates counter clockwise as viewed from the top, the rotation is to correct and installation may proceed. If the motor rotates clockwise as viewed from the top, reverse any two of the three power leads and motor rotation will be reversed.

CAUTION

Operation of the pump in a clockwise (as viewed from the top) direction will cause the line shaft couplings to unthread, causing serious damage to the pump.

D. Impeller adjustment is required to achieve the preferred running position of the impeller within the pump bowl. Also, the impeller must not nib on the bowl seat.

1. Determine the correct impeller position from the Technical Data page found in the drawing section of this manual.
2. Thread the adjusting nut upwards toward the driver half coupling until the correct amount of gap "A" is reached (refer to the above illustration).
3. Adjust to the position that bolt holes line up and insert coupling bolts. Torque to the values as shown the coupling dimension and technical data page in the drawing section of this manual. Install the set screw in the pump coupling hub and secure.
4. Install protective guards.

WARNING

Make sure the protective guard is in place on the discharge head before operating the pump.

NOTE

Extremely long pumps (deep settings) may require additional nut adjustment to accommodate line shaft stretch. Extra adjustment is not generally required for pumps less than 150 feet in length. For pumps over 150 feet long, consult the factory for instructions.

- E. Refer to the driver manual to assure that all lubrication instructions have been followed completely.
- F. Refer to the driver manual to assure that all safety procedures are completely understood and implemented prior to operation.

CAUTION

Grease lubricated drivers are shipped pre-lubricated. Oil lubricated drivers and right angle gears are shipped dry and require an initial fill of the manufacturer's recommended lubricant prior to start-up. See driver manufacturer's manual for lubrication specifications. Initial start-up lubricants are not supplied by the manufacturer.

SECTION 4 OPERATION

General

Because variations may exist in both the equipment and in the particular installation of the a pump and driver, specific operating instructions are not within the scope of this manual. However, there are general rules and practices that apply to all pump installations and operation.

CAUTION

Before starting or operating the pump, read this entire manual, especially the following instructions.

Before starting the pump:

1. Rotate the unit or assembly by hand to assure all on moving parts are free.
2. Install coupling guards around all exposed rotating parts. Guards are mandatory on discharge head (motor pedestal) openings if the pump is equipped with an adjustable coupling.
3. Install packing (or mechanical seal).
4. Install water line to packing box (for mechanical seals).
5. Observe all **DANGER, WARNING** and **CAUTION** tags attached to this equipment.
6. Ensure water in sump is at the specified level for adequate submergence.
7. If pump has a packed box, adjust the packing gland finger tight. Refer to Packing Adjustment in the maintenance section to properly adjust packing.

If excessive vibration or noise occurs during operation, shut the pump down and review the Trouble Shooting section. If the problem cannot be corrected, consult a Layne/Verti-Line representative.

Operating at Reduced Capacity

In a typical application covering a wide range of flow rates a variable speed driver is often used to adjust pump and this is taken into consideration by Layne/Verti-Line when selecting the pump and impeller trim. Although these pumps are applicable over a wide range of operating conditions, care should be exercised when doing so when the actual conditions differ from the sold conditions. You should always contact your nearest Layne/Verti-Line distributor or factory before operating the pumps at any condition other than that for which they were sold.

Generally, these pumps can be operated continuously at capacity equal to 60% of the pump capacity at the best efficiency point, and at higher capacities.

Initial Startup

Inspect the complete installation to ensure that the installation instructions of this manual, and the manuals of all the related equipment, have been followed and that the installation is complete.

Ensure that the driver is properly serviced, and that the proper pump rotation is obtained.

Rotate the pump shaft by hand. It should rotate freely on motor driven installations.

Ensure the discharge valve is open.

Start the pump according to the following procedure:

1. Start the driver according to the driver manufacturer's instructions.
2. Immediately after the pump has been started, check lubrication system, stuffing box lubrication and operation, and pump noise level. Continue to monitor these for the first several hours of operation.

3. Check the driver and other necessary equipment for satisfactory operation following their manuals.
4. Check the foundation for integrity.
5. After the first shutdown, repeat the impeller adjustment. Running may have tightened up some of the shaft joints, changing the original setting.

Normal Operation

Monitor the following during running cycles:

1. Unit vibration or noise.
2. Driver lubrication levels and flow.
3. Packing box leakage.

Check the following before normal startup:

1. Driver lubrication levels and flow.
2. General condition of all equipment.

Shutdown

Pump stations are usually designed to have the pumps started and stopped automatically. Since this is a function of station design, the operators should be familiar with the systems operating parameters. The general procedure to shut down the pump is as follows:

1. Disconnect the electrical power source.
2. If the pump is to be removed for repair, close the discharge valve.

WARNING

After removal of pump, ensure pump opening is adequately covered and secured.

Seasonal Operating Instructions

If the pump is located in an area that is subject to below freezing temperatures and will not be operated enough to prevent freezing, it should be drained to prevent damage to the casing caused by freezing.

Emergency Procedures

Many installations are equipped with emergency shut off switches near the pump location. These locations should be plainly marked and readily accessible at all times.

The control panel (if used) may be equipped with an emergency start/stop button or switch.

IMPORTANT

The operator or persons working around the equipment should be familiar with locations of emergency start-up and shut off points.

Start-Up

1. Open the suction valve.
2. Start the driver
3. Open the discharge valve.

Shutdown

1. Shut off the power at the nearest switch.

Troubleshooting

If you have followed the installation and start up procedures outlined in this manual, your pump should provide reliable service and long life. However, if operating problems occur, significant time and expense can be saved if you use the following checklist to eliminate the most common causes of those problems.

Pump Symptoms

Insufficient Pressure or Flow

1. Wrong direction of rotation.
 - a. Reverse any two motor lead connections. Check driver O & M.
2. Discharge head too high.
 - a. Change system.
 - b. Raise wet well level.
 - c. Install larger impeller & driver.
3. Impeller running clearance too great.
 - a. Reset impeller clearance per O & M manual.
4. Insufficient suction bell submergence.
 - a. Raise wet well level.
5. Speed too low.
 - a. Check driver speed and voltage.
6. Bowl passage partially plugged.
 - a. Clean bowl passages.
7. Impeller passage partially blocked.
 - a. Clean impeller passages.
8. Clogged suction.
 - a. Clean suction passages.
9. Low water level.
 - a. Raise wet well.
10. Air in liquid.
 - a. Increase submergence to prevent vortexing.
11. Improper sump design.
 - a. Change sump design.
 - b. Increase submergence to prevent vortexing.

12. Impeller damaged.
 - a. Check and repair or replace.
13. Impeller diameter too small.
 - a. Replace impeller with one with a larger diameter. Check driver HP.

Loss of Suction Operation

1. Low water level.
 - a. Raise wet well level.
2. Insufficient suction bell submergence.
 - a. Raise wet well level.
3. Wrong direction of rotation.
 - a. Reverse any two motor lead connections. Check driver O & M.
4. Air or gasses in liquid.
 - a. Deaerate liquid.
 - b. Increase submergence to prevent vortexing.

Excessive Power Consumption

1. Improper impeller adjustment causing rubbing.
 - a. Readjust impeller clearance setting as outlined in this manual.
2. Head lower than rating, pumps operating over capacity.
 - a. Change system. Reduce pump speed. Trim impeller.
3. Speed too high.
 - a. Check driver speed and voltage.
4. Improper voltage to driver.
 - a. Check driver voltage.
 - b. Change power source or driver.
5. Misalignment.
 - a. Check motor/pump to base connections. Realign coupling.
6. Packing box gland too tight.
 - a. Readjust packing gland.
7. Incorrect impeller diameter.
 - a. Determine correct impeller diameter and replace or trim impeller.
8. Shaft bent.
 - a. Replace shaft.

9. Specific gravity or viscosity of liquid pumped is too high.
 - a. Reduce pump capacity.

Vibration or Noise

1. Foundation bolts loose or defect in grouting.
 - a. Tighten foundation bolts and/or re-grout.
2. Worn pump bearings.
 - a. Replace pump bearings.
3. Pipe strain-improperly supported or improperly aligned.
 - a. Check pipe supports and adjust or realign.
4. Head lower than rating, pumps too much liquid.
 - a. Increase system head.
 - b. Reduce pump speed. Trim impeller.
5. Misalignment between driver and pump
 - a. Realign driver and pump.
6. Shaft bent.
 - a. Replace shaft.
7. Pump running at shut-off condition.
 - a. Open discharge valve. Check for obstructions.
8. Insufficient suction bell submergence.
 - a. Increase submergence.
9. Low water level.
 - a. Increase wet well level.
10. Air in liquid.
 - a. Increase submergence to prevent vortexing.
11. Impeller passages clogged.
 - a. Clean impeller passages.
12. Foreign object in pump.
 - a. Remove foreign object.
 - b. Check for damage.
13. Bad driver bearing.
 - a. Replace driver bearing.
14. Improper sump design.
 - a. Change sump design. Increase submergence to prevent vortexing.

Excessive Packing Box Leakage

1. Gland not properly tightened.
 - a. Adjust packing gland.
2. Worn packing or sleeve.
 - a. Replace packing and/or sleeve.
3. Ends of packing not staggered.
 - a. Repack to stagger packing ends.
4. Bypass is plugged or restricted.
 - a. Clean by-pass line.

Over-Heating

1. Packing gland too tight.
 - a. Adjust packing gland.
2. Water flush line plugged.
 - a. Clean water flush line.
3. Shaft bent.
 - a. Replace shaft.

Motor Symptoms

The trouble or symptoms, their probable causes and suggest remedies contained in this trouble shooting guide will assist you in quickly determining and correcting most problems should they occur.

It is not the intent of Layne/Verti-Line to replace the recommendations of the motor manufacturer in regard to operation and maintenance of the motor. Rather, this guide is offered as a supplement to such data.

Any specific questions or problems should be directed to the manufacturer of the motor. Be sure to supply relevant data from the motor nameplate when inquiring about service or maintenance.

DANGER

Electrical power must be disconnected and locked to prevent accidentally starting during mechanical systems check.

DANGER

Electrical trouble shooting must be performed by qualified electricians skilled in the use of electrical instruments.

Motor Does Not Start

1. Break in power supply circuit.
 - a. Blown or defective primary fuses or open circuit breakers.
 - (1) Check voltage across all phases above the disconnect switch. Replace fuses or reset breakers.
 - b. Blown or defective secondary fuses or open circuit breakers.
 - (1) Check voltage across all phases below disconnect (with disconnect closed). Replace fuses or reset breakers.
2. Open control circuit.
 - a. Overload trips are open.
 - (1) Push reset button.
 - b. Defective holding coil in magnetic switch.
 - (1) Push start button and allow sufficient time for operation of time delay.
 - (2) If voltage is measured, coil is defective.
 - (3) If no voltage is measured, control circuit is open
 - c. Loose or poor connections in control circuit.
 - d. Make visual inspection of all connections.
 - (1) Tighten as necessary.

3. Magnetic switch closes.
 - a. Poor switch contact.
 - (1) Open manual disconnect switch, close magnetic switch by hand and examine contactors and springs.
 - b. Open circuits in control panel.
 - (1) Open manual disconnect switch, close magnetic switch by hand and examine contactors and springs.
 - c. Open circuits in leads to motor.
 - (1) Check voltage at T1-T2-T3.
 - d. Leads improperly connected.
 - (1) Check lead numbers and connections.

Motor Fails To Come Up To Speed

1. Low or incorrect voltage.
 - a. Check voltage at T1-T2-T3 in control panel.
2. Incorrect connections at motor.
 - a. Check for proper lead connections at motor.
 - (1) Compare with connection diagram of motor.
3. Mechanical overload.
 - a. Check for tight or locked shaft.
4. Hydraulic overload.
 - a. Check pump flow and head against performance curve.

Motor Runs Hot

1. Inadequate ventilation.
 - a. Assure adequate supply of fresh air.
 - 1) Check air blast through motor by feeling air discharge at bottom of motor.
2. Overload.
 - a. Check for tight or locked shaft.
 - b. Check pump flow and head against performance curve.

3. Unbalanced supply voltage.
 - a. Check supply voltage with volt meter.

Motor Vibrates

1. Motor and pump mis-aligned.
 - a. Re-align pump and motor.
2. Worn bearings or bent shaft.
 - a. Disconnect pump from motor and run motor only.
 - (1) Repair as necessary.
3. Hydraulic disturbance in discharge piping.
 - a. Check piping.
4. Unbalanced rotor assembly.
 - a. Balance rotor.
5. Motor not mounted securely.
 - a. Secure properly and check alignment.

Motor Is Noisy

1. Worn thrust bearings.
 - a. Remove dust cover; rotate rotor by hand and make visual inspection of balls and races.
 - (1) Bearing noise is usually accompanied by high frequency vibration.
2. Electrical Noise.
 - a. Most electrical motors are noisy during the starting period. The noise should diminish as motor reaches full speed.

Incorrect Rotation.

1. Incorrect connections.
 - a. Refer to connection diagram and reconnect according to instructions. Usually switching any two wires on a 3 phase motor will change rotation.

SECTION 5 MAINTENANCE

Preventive Maintenance

To assure satisfactory operation of the pump, scheduled inspection and periodic maintenance are required. We suggest an inspection and maintenance log be kept and the inspector immediately report any problems.

This Layne/Verti-Line model 1100 vertical turbine pump is supplied with product lubricated column and bowl bearings. The suction bell bearing is grease packed at the factory. It is not necessary to re-lubricate this bearing except when the pump is to be torn down for maintenance and the bowl assembly is to be disassembled.

A guide for preventive maintenance for normal applications is given below. Unusual applications with abnormal heat, moisture, dust, etc., may require more frequent inspection and service.

Item	Action Required
Seal Box	Inspect every 150 hrs of operation for excessive leakage. Adjust or replace packing as required. Repair or replace Mechanical Seal
Driver Bearings	Lubricate according to instructions given in the driver O&M in Section 8 of this manual.
Pump Alignment	Check for changes annually. Correct as required.
Noise Level	Check for changes annually. Correct as required.
Pump Vibration	Check for changes annually. Correct as required.

Grease Recommendation

The following lubricants are recommended for both potable and non-potable pumping systems:

Non-Potable System

Manufacturer	Type
Generic	N.L.G.I. #2 Lithium base multi-purpose grease with a mineral oil viscosity of 750-1050 SSU at 100°F and 75-82 SSU at 210°F
Atlantic Richfield	ARCO MP #2
Gulf	Gulfcrown #2
Sinclair	Litholine MP #2
Texaco	Marfak #958

Potable Water System

Generic	N.L.G.I. #2 meeting FDA Regulation 178.3570 and has USDA Type H-1 and FDA approvals for incidental food contact
Chevron	FM Grade 2
Ideal	FG #2
Keystone	Nevastone HT/AW2
Lubriplate	FGL-2
Mobile	FM Grade 2

Mechanical Seal

The pump furnished on this order is equipped with a mechanical seal. Refer to the Mechanical Seal section of this manual for instructions regarding maintenance of the seal.

Packing Adjustment

Generally, packed box pumps should be checked every 150 hours of operation and the glands should be readjusted if necessary. Initial adjustment is accomplished by tightening the gland nuts finger tight.

CAUTION

Excessive tightening of the glands may cause shaft sleeve damage.

Packing Replacement

For general service application with pump temperature (0° C to 93° C), use a good grade of soft, square, long fiber graphite packing thoroughly lubricated.

For best results, use only genuine Layne/Verti-Line replacement packing. The replacement procedure should be as follows:

- A. Stop the pump.

DANGER

Lock out electrical power to prevent accidental starting and causing possible personal injury.

- A. Unbolt and remove the gland.
 B. Use a flexible packing tool* with a hook attachment for removal of the packing.
 *The packing tool can be purchased from the factory or local supply house.
 C. Clean the packing box and shaft sleeve.
 D. Inspect the shaft sleeve for wear or rough finish and replace the sleeve with a genuine Layne/Verti-Line sleeve if necessary.
 E. Install the new packing.

IMPORTANT

Stagger the packing end joints 180° and firmly seat each ring of packing as you install it.

- A. Refer to the technical data section for pertinent stuffing box and packing dimensions.
 B. Reinstall the gland and tighten the gland nuts finger tight. After the pump has been started adjust the glands so that there is a steady stream, approximately 1/8" diameter, from the packing box.

Pump Disassembly**WARNING**

Read this entire disassembly procedure and refer to the sectional drawings in this manual before starting.

Major maintenance beyond lubrication, adjustment of impeller or wear ring clearance, and replacement or adjustment of the packing will require disassembly of the pump. The following are step-by-step instructions and are essentially the reverse of the installation procedure.

Driver Removal**Vertical Hollow Shaft (VHS) Driver**

- A. Stop the pump and lock out the power to the driver. Close the discharge valve. Disconnect the electrical cables from the driver. Disconnect and remove gauges and all other auxiliary piping. (Stuffing box lubrication, oil, or grease lines, etc.)

DANGER

Check with proper electrical testing equipment to be certain all electrical power to the driver and accessories associated with the pump is disconnected.

- B. Remove the driver cover, adjusting nut lockscrew, and gib key. Lower the shaft until the impeller rests on the bowl seat. Remove the adjusting nut and driver coupling.
 C. Disconnect the shaft coupling under the driver (if used) and remove the top shaft. Remove the capscrews holding driver to discharge head or pedestal.
 D. Lift the driver from the head and set aside.

Vertical Solid Shaft (VSS) Driver

- A. Stop the pump and lock out the power to the driver. Close the discharge valve. Disconnect the electrical cables from the driver. Disconnect and remove gauges and all other auxiliary piping. (Stuffing box lubrication, oil, or grease lines, etc.)

DANGER

Check with proper electrical testing equipment to be certain all electrical power to the driver and accessories associated with the pump is disconnected.

- B. Remove the bolts holding the coupling halves together slowly so that the impeller does not drop.
- D. Remove the capscrews holding driver to discharge head or pedestal.
- E. Lift the driver from the head and set aside.

CAUTION

Always use protective eyewear.

Discharge Head Removal

- A. Remove and disassemble the pump head, the column, packing box and shafting according to the following procedure which is essentially the reverse of the installation procedure.
- B. Remove the packing gland bolts (8, 8A), glands (9), water slinger (6) and packing (15).
- C. Loosen and remove all the discharge piping flange bolts.

WARNING

Use a guide rope going from the sling joint, the head, attached to the discharge flange. This will keep the head from tipping over, possibly causing personal injury.

- D. Remove the packing box bolts and remove the packing box from the head

and shaft to a work area for inspection & cleaning.

The packing box bearing (17A) is an interference fit in the packing box. The removal of this bearing will require the use of a mechanical press the bearing maybe removed by machining or other similar methods. Use care when removing bearings to not damage bores or hubs.

- E. Lift entire unit with the lifting lugs and install a column clamp just below the upper column flange leaving room to remove the flange bolting. Lower unit so that the column clamp rests on adequate supports.

DANGER

Use a crane or hoist of adequate capacity to prevent serious personal injury.

- F. Remove the bolts holding the column to the discharge head. Lift the discharge head off the unit and set aside.

Column Removal

Flanged Column

- A. Install eyebolts of sufficient size in the column flange holes and lift the unit and reposition the clamp below the next column flange.
- B. Use column and shaft clamps (or other acceptable method) to safely support and lift this assembly.
- C. Unbolt column flange and lift column enough to loosen the shaft coupling. When all components are loose, carefully lift this assembly from the pump unit. With soft skid boards under the column to protect the flange, slowly lower the column and shaft assembly onto the floor and move to a convenient work area.

IMPORTANT

Shaft threads are left-hand rotation.

- D. Repeat above steps A, B & C until all column and shaft sections have been removed from the unit.
- E. Remove the bearing retainer assembly for inspection and cleaning.
- F. Remove shaft section from column pipe. Remove couplings from shafts and inspect for wear or damage.
- G. Inspect bearings and retainers for damage.
- H. If the top and intermediate drive shaft sleeves (13 & 29) show wear or damage remove the sleeve by heating it to 350°F-400°F to break the Loctite bond.

IMPORTANT

Measure and record the position of the sleeves (13 & 29) on the shafts before removal. They must be put back in exactly the same place.

CAUTION

To prevent possible serious personal injury always wear heat resistant gloves when handling heated parts.

- I. Refer to Pump Bowl Disassembly for detailed bowl disassembly procedures.

Threaded Column

- A. Install eyebolts of sufficient size in the column flange holes and lift the unit and reposition the clamp below the next column coupling.
- B. Use column and shaft clamps (or other acceptable method) to safely support and lift this assembly.
- C. Unscrew the column coupling and lift column enough to loosen the shaft coupling. When all components are loose, carefully lift this assembly from the pump unit. With soft skid boards under the column to protect the threads, slowly lower the column and shaft assembly onto the floor and move to a convenient work area.

IMPORTANT

Shaft threads are left-hand rotation.

- D. Repeat above steps A, B, and C until all column and shaft sections have been removed from the unit.
- E. Remove the bearing retainer assembly for inspection and cleaning.
- F. Remove shaft section from column pipe. Remove couplings from shafts and inspect for wear or damage.
- G. Inspect bearings and retainers for damage.
- H. If the top and intermediate drive shaft sleeves (13 & 29) show wear or damage remove the sleeve by heating it to 350°F-400°F to break the Loctite bond.
- I. Refer to Pump Bowl Disassembly for detailed bowl disassembly procedures.

Pump Bowl Disassembly

For disassembly of the pump bowls, proceed in accordance with steps listed below. Select a clean area for work. Refer to assembly drawing and parts list for part identification.

Flanged Bowls

- A. Place the bowl assembly in a horizontal position, blocked to prevent rolling.
- B. Measure and record the axial end play of the shaft. This must be checked on reassembly of the bowls.
- C. Remove the shaft coupling(31).
- D. Remove the capscrews holding the discharge case (54) and top intermediate bowl (55) and remove from the pump shaft (32) and set aside for inspection. It is not necessary to disassemble these two bowls unless bearings are to be replaced.
- E. Remove the impeller (38) and collet (39) from the pump shaft according to the following procedure:
 1. To remove the collet from the impeller, pull the shaft upwards until the impeller is in its highest position. Using a collet driver (see Assembly Tools at the end of this section) drive the impeller off the collet.
 2. To remove the collet, insert a screwdriver in the collet slit and wedge apart; the collet will slide easily off of the shaft.
 3. If impellers are to be reused, they should be marked so that they are re-installed in the same position.
- F. Remove the capscrews holding the next intermediate bowl (36). Remove the intermediate bowl from the pump shaft and set aside for inspection.
- G. Repeat steps E & F until all bowls and impellers have been removed.

- H. Remove the shaft from the suction bell (40), or suction case.
- I. Measure and record the location of the sand collar (58). Remove the sand collar only if it is damaged and replacement is required.
- J. This pump may be fitted with wear rings by machining the bowls (or impellers) for a ring seat. Refer to Wear Rings section of this manual for instructions on adding wear rings or replacing existing rings.

Threaded Bowls

NOTE

For disassembly of the pump bowls, proceed in accordance with steps listed below.

- A. Place the bowl assembly in a horizontal position, blocked to prevent rolling.
- B. Measure and record the axial end play of the shaft. This must be checked on reassembly of the bowls.
- C. Remove the shaft coupling (31).
- D. All bowl threads are right-hand. To prevent the possibility of bowl threads loosening during operation, all such bowls are drilled and pinned at the parting line with a 3/16" pin. Disassembly of threaded bowls requires that the pins be drilled out. At reassembly, the bowls should be re-pinned for security.
- E. Unscrew the discharge case (54) and remove the discharge case from the pump shaft and set aside for inspection.
- F. Unscrew and remove the top bowl (55) and set aside for inspection
- G. Remove the impeller (38) and collet (39) from the pump shaft according to the following procedure:
 1. To remove the collet from the impeller, pull the shaft upwards until the impeller is in its highest position. Using a collet (see Assembly Tools at

the end of this section) driver drive the impeller off the collet.

2. To remove the collet insert a screw driver in the collet slit and wedge apart; the collet will slide off of the shaft.
 3. If impellers are to be reused, they should be marked so that they are re-installed in the same bowl.
- H. Unscrew the next intermediate bowl (36). Remove the intermediate bowl from the pump shaft and set aside for inspection.
- I. Repeat steps G & H until all bowls and impellers have been removed.
- J. Remove the shaft from the suction bell (40), or suction case.
- K. Measure and record the location of the sand collar (58). Remove the sand collar only if it is damaged and replacement is required.
- L. The pump bowl assembly is now disassembled and ready for inspection.
- M. This pump may be fitted with wear rings by machining the bowls (or impellers) for a ring seat. Refer to Wear Rings section of this manual for instructions on adding wear rings or replacing existing rings.

Inspection for Replacement

After the components are disassembled, each part should be thoroughly cleaned and inspected for wear and physical damage. During cleaning, do not allow any petroleum-based solvents on rubber bearings.

It is not necessary to remove bearings unless inspection indicates replacement is necessary. If it is necessary to remove bearings, they should be pressed from their seats and discarded.

CAUTION

Use care not to damage bores or hubs during bearing removal.

Any parts showing signs of excessive wear or damage should be replaced with genuine Layne/Verti-Line parts. Maximum clearances are shown on the technical data page found in the drawing section of this manual.

- A. Inspect the shafting (23) at each bearing location for damage or excessive wear and replace shaft if not salvageable.
- B. Inspect all line shaft bearings (26), packing box bushing (17A), and all bowl bearings (34, 35, 41, 50) for wear and excessive clearance. If the diametrical bearing clearance exceeds the limits, the bearings must be replaced.
- C. Inspect the bowl and/or impeller wear ring (if so equipped) for wear and excessive clearance. The correct clearance is shown on the technical data page in the drawing section of this manual. The ring should be replaced with a genuine Layne/Verti-Line replacement part.
- D. Inspect the shaft sleeves for wear. Replace as necessary. If the sleeves (13 & 29) show wear or damage, remove the sleeve(s) by heating it to 350°-400° F to break the Loctite bond.

CAUTION

If it is found that any of the bearings or sleeves have excessive wear, it is recommended that all bearings and sleeves be replaced (including bowl bearings).

CAUTION

Measure and record the position of the sleeve (13) on the shaft (19) before removal.

WARNING

To prevent possible serious personal injury, heat resistant gloves must be worn when handling heated parts.

Shaft Straightness

Prior to installation or reassembly, bowl shafts and line shaft should be checked for straightness. The maximum allowable total indicated runout must be less than .005".

Refer to the following illustrations showing the proper positions at which dial indicator readings should be taken. The shaft should be supported in V-blocks or on rollers as shown. Position the dial indicator and zero the dial face. Slowly rotate the shaft and observe the maximum runout.

If the shafts exceed the .005" maximum limit, straightening will be required. Consult the Layne/Verti-Line factory for straightening recommendations, or a local qualified machine shop.

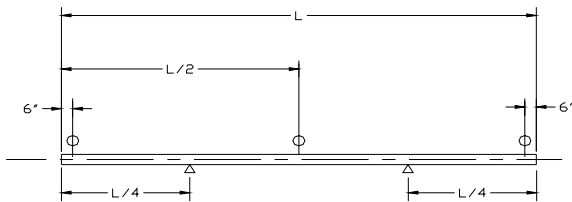


Figure C
(Shafts 10 ft long or less)

Pump Bowl Assembly

Prior to the start of reassembling the pump bowl the following is to be done:

- A. Apply grease to the bowl registers to improve assembly alignment.
- B. Clean all components before starting the assembly. Do not apply any petroleum based solvents to rubber bearings.
- C. Install bearings in their respective bowls if they have been removed. If they have not been replaced, they should be thoroughly cleaned and lubricated with a thin film of grease (except rubber bearings).
- D. Install new wear rings if they are to be replaced in all bowls. Refer to Wear Rings section of this manual for instructions.

- E. Remove the pipe plug from the suction bell and remove old grease. Apply a thin film of multi-purpose grease to the shaft and the suction bowl bearing. See Grease Recommendation in the drawing section of this manual.
- F. Lay out the parts in the order in which they will be assembled. Reused impellers are to be re-installed in the same bowl in which it was originally installed.
- G. Install shaft sleeves as required according to the following procedure:
 1. Refer to the previously recorded sleeve locations and scribe or mark shaft accordingly.
 2. Thoroughly clean the sleeve and shaft in the sleeve area using a cleaner as recommended by Loctite.
 3. Apply a coat of Loctite 609 on the shaft in the correct sleeve location area. Slide the sleeve over the shaft, rotating it several times while at the same time moving the sleeve axially on the shaft. This will spread the Loctite evenly.
- H. Proceed with the assembly of the pump bowl as follows:

Flanged Bowls

- A. Put the suction bell (case) in a horizontal position and block from rolling. Insert the pump shaft into the bearing as far as it will go. Insert a shaft locating tool (refer to Assembly Tools found at the end of this section) through the pipe tap in the suction bell and fasten to the pump shaft. Tighten securely.
- B. Install the sand collar if it has been removed and secure with setscrews.
- C. Install the first impeller over the pump shaft and into position in the suction bell (case) seat. The impeller should rotate freely in the bowl. If it binds, remove and determine the cause.

- D. Open a lock collet slightly and slide over the pump shaft and into the impeller. Using a collet driver (refer to Assembly Tools at found at the end of this section) drive the lock collet into place in the impeller bore. This will require substantial force to make sure the collet is properly seated. An experienced mechanic will be able to detect the change in sound when the collet has properly seated.

CAUTION

Failure to properly seat the impeller drive collet will result in damage to the pump.

- E. Install the intermediate bowl and tighten capscrews.
- F. Repeat steps C, D and E to install all additional stages until all pump bowls have been reassembled.
- G. Install the top intermediate bowl (55) and discharge case (54) over the pump shaft and bolt in place with capscrews and nuts.
- H. Remove the shaft locating tool holding the pump shaft in place. Check the bowl end play. It should be the same as previously recorded (or very close). If it is not, the bowl assembly should be disassembled to determine the reason. Pack the cavity with grease and replace the pipe plug in the suction bell (case) hub.
- I. Install the coupling (31) on the pump shaft.
- J. The bowl assembly is now complete.
- K. Refer to Wear Rings for instructions on wear ring replacement, if wear ring replacement is required.
- L. Refer to the Installation Section of this manual to complete pump assembly and reinstallation.

Threaded Bowls

- A. Put the suction bell (case) in a horizontal position and block from rolling. Insert the

pump shaft into the bearing as far as it will go. Insert a shaft locating through the pipe tap in the suction bell and fasten to the pump shaft. Tighten securely.

- B. Install the sand collar if it has been removed and secure with setscrews.
- C. Install the first impeller over the pump shaft and into position in the suction bell (case) seat. The impeller should rotate freely in the bowl. If it binds, remove and determine the cause.
- D. Open a lock collet slightly and slide over the pump shaft and into the impeller. Using a collet driver (refer to Assembly Tools at found at the end of this section) drive the lock collet into place in the impeller bore. This will require substantial force to make sure the collet is properly seated. An experienced mechanic will be able to detect the change in sound when the collet has properly seated.

CAUTION

Failure to properly seat the impeller drive collet will result in damage to the pump.

- E. Install the intermediate bowl and tighten securely.
- F. Repeat steps C, D, & E to install all additional stages until all pump bowls have been reassembled.
- G. Install the top intermediate bowl and tighten securely.
- H. Install the discharge case and tighten securely.
- I. Remove the shaft locating tool holding the pump shaft in place. Check the bowl end play. It should be the same as previously recorded. If it is not, the bowl assembly should be disassembled to determine the reason. Pack the cavity with grease and replace the pipe plug in the suction bell (case) hub.
- J. Pin each threaded joint using a 3/16 x 1/2 pin.

- K. Install the coupling (31) on the pump shaft.
- L. The bowl assembly is now complete.
- M. Refer to Wear Rings for instructions on wear ring replacement, if wear ring replacement is required
- N. Refer to the Installation Section of this manual to B. Apply a bead of Loctite 290 completely around the complete pump assembly and reinstallation.

Wear Rings

If the pump is equipped with wear rings and replacement is required, refer to Wear Ring Removal below.

Wear Ring Removal

- A. If the wear ring requires replacement it can be more easily removed by heating it to 250° - 400° F.

WARNING

To prevent possible serious personal injury, heat resistant gloves must, be worn when handling heated parts.

- B. The ring may also be removed by splitting with a chisel and removed or machined.

Installing New Wear Ring

CAUTION

Care should be used to avoid damage to the bowl ring seat.

IMPORTANT

If this bowl assembly is to be fitted with wear rings and was not equipped with wear rings at the factory, contact the factory for correct dimensions.

CAUTION

Machine work should be done by a qualified machinist experienced in similar machining work. If the wear rings are to be replaced they should be replaced with genuine Layne/Verti-Line wear rings. Install the wear rings as follows.

CAUTION

To prevent possible serious personal injury, approved safety glasses must be worn when grinding.

- A. To ensure proper bonding, thoroughly clean all mating parts with solvent to remove all grease, oil, dirt, etc.
- B. Apply a bead of Loctite 290 completely around the middle of the impeller or bowl wear ring fit, and press the wear ring(s) in place.

IMPORTANT

To avoid distortion and ensure proper installation, be careful to press the wear rings evenly and completely in place. They should be firmly butted against the corresponding impeller or bowl shoulder at the bottom of the wear ring fit.

Mechanical Seals

The mechanical seal covered by these instructions, when properly installed, will give satisfactory performance. To ensure the proper installation these instructions should be read carefully.

Description

Several types of mechanical seals are used. The most common types are the single inside seal, single outside seal and a cartridge type seal. Since seals supplied by different vendors may vary slightly these instructions are general in nature. Refer to any specific installation instructions that may be supplied with your pump or contact the factory.

Mechanical Seals

The mechanical seal covered by these instructions, when properly installed, will give satisfactory performance. To ensure the proper installation these instructions should be read carefully.

Description

Several types of mechanical seals can be used. The most common types are the single inside seal, single outside seal and the outside cartridge type seal. Since seals supplied by different vendors may vary in design, these instructions are general in nature. Refer to the seal manufacturer's specific installation instructions supplied with your pump or contact the factory.

General Application

The seals described in these instructions are acceptable for use in pumps handling water. They are not recommended for handling fluids which are highly acidic, highly alkaline, or contain abrasives or dissolved substances that tend to crystallize.

Seal Housing

If replacement is required, use the following procedure to install the seal housing prior to installing the mechanical seal.

- A. Remove the capscrews (431A) which hold the seal housing (17B) to the discharge head (or the driver pedestal).
- B. Remove the original throttle bushing (17A) and seal housing gasket (11). Thoroughly clean the mating surfaces of the seal housing and discharge head.
- C. If a single inside seal, remove the old stationary seat (456A) from the seal gland (431).
- D. Install the throttle bushing (17A) into the seal box housing (17B).
- E. Install the seal housing gasket (11) onto the seal housing (17B).
- F. Install the seal housing with gasket (17B & 11) on to the discharge head (or driver pedestal), and secure with capscrews (431A)
- G. If a single inside seal, install the new stationary seat (456A) into the seal gland (431) using an o-ring lubricant or liquid soap on the o-ring.

Seal Installation

Prior to installation, inspect the seal, seal housing and gland.

IMPORTANT

Seal faces are lapped and polished to a mirror finish. It is imperative that sealing faces be handled with care and kept perfectly clean. DO NOT touch the sealing faces.

CAUTION

When installing a seal over a headshaft without a sleeve, care must be taken so as to not damage the seal O-ring when passing over the shaft threads. Ensure shaft threads are clean and free from burrs. It may be necessary to lubricate the shaft threads with an o-ring lubricant or wrap with plumbers tape prior to installing the seal.

Inside Single Seal

Use the following general procedure to install this type of seal:

- A. Install the stationary seat (456A) into the seal gland (431) using an o-ring lubricant or liquid soap on the o-ring.
- B. Install the motor. Install the drive shaft (19) if VHS motor, and tighten the shaft coupling. Install the flanged adjustable coupling if VSS motor.
- C. Adjust the impellers per instructions in this manual. Refer to the technical data page in the drawing section of this manual for the correct impeller setting.
- D. With scribe or marker, place a mark on the shaft (or shaft sleeve if present) that is level with the seal housing (17B) face.
- E. Position the end of the rotating seal (456) flush with the mark on the shaft (or shaft sleeve if present) and tighten the locking screw.
- F. Pull the seal gland (431) down and secure with capscrews (431A).
- G. Connect piping to seal gland (431).

Outside Single Seal

Use the following general procedure to install this type of seal.

- A. Install the seal gland (431) containing the stationary seat (456A) on the seal housing face and secure with capscrews.
- B. Install the rotating seat (456) and retainer (456B) ring over the shaft or sleeve. Do not fasten the retainer to the shaft (or shaft sleeve if present) until impellers have been properly adjusted.
- C. Install the motor. Install the drive shaft (19) if VHS motor, and tighten the shaft coupling. Install the flanged adjustable coupling if VSS motor.
- D. Adjust the impellers per instructions in this manual. Refer to the technical data page in the drawing section of this manual for the correct impeller setting.
- E. Compress the retainer (456B) and rotating assembly (456) until the correct spring gap is attained. The gap is stamped on the seal retainer or may be included with the seal manufacturers printed instructions.
- F. Secure the retainer ring (456B) with setscrews.
- G. Connect piping to seal gland (431).

Cartridge Seal

Use the following general procedure to install this type of seal:

- A. Install the complete seal assembly on the seal housing. Do not secure with provided hardware at this time.
- B. For split cartridge seals, refer to the seal manufacturer's specific installation instructions. Impeller adjustment is required prior to installation.
- C. Install the motor. Install the drive shaft (19) if VHS motor, and tighten the shaft coupling. Install the flanged adjustable coupling if VSS motor.
- D. Adjust the impellers per instructions in this manual. Refer to the technical data page in the drawing section of this manual for the correct impeller setting.
- E. Secure complete seal assembly with supplied hardware.
- F. Secure collar set screws.
- G. Remove plastic tabs, setting devices, or pull cord to set proper spring compression.
- H. Connect piping to seal gland (431).

IMPORTANT

All seals, regardless of type or manufacturer, must be piped to purge all air out of the seal housing cavity. The appropriate API Piping Plan for the installation should be employed.

Operation

Special operating techniques are involved when using pumps equipped with mechanical seals. Certain precautions should be taken as follows:

Installation, Operation and Maintenance

- A. The seal should never be operated dry, even to check for rotation. A water source must be provided to cool and lubricate the seal faces during pump operation. The lubricating water can be either the pumped media or an external water source.

IMPORTANT

To prolong seal life, it is recommended on all installations to lubricate the mechanical seal prior to each motor start.

- B. If the pumped media is used for seal cooling and lubrication, a vent line must be provided to prevent air entrapment in the seal cavity, such as demonstrated by API Plan 13.
- C. Lubrication via the pumped media is not recommended for vertical turbines in which 1) the lift is in excess of 35 feet, or 2) they are to be operated by a soft start or variable frequency drive. The excessive time required for the pumped media to reach the seal at each start will result in premature seal failure. In these situations, an external water source is required.
- D. If an external water source is used, it must be clean to within 100 microns and introduced to the seal prior to each motor start.
- E. If an external water source is used to flush the seal during operation, adequate flow must be provided to maintain 15 fps minimum velocity between the throttle bushing and shaft.

Shaft or Sleeve Dia.	Flow Rate (GPM)
1	¾ to 1 ¼
1 ¼	1 to 1 ½
1 ½	1 ¼ to 1 ¾
1 11/16	1 ¼ to 1 ¾
1 15/16	1 ½ to 2 ¼
2 3/16	1 ¾ to 2 ½
2 7/16	2 to 2 ¾
2 11/16	2 to 3

- F. All seal plumbing should follow the appropriate API Piping Plan for the installation and application.
- G. Some seals may weep at initial start-up. This condition should cease after a short period as the seal faces lap together. Operate and monitor the seal until leakage subsides, in no case should it exceed 60 drops per minute.

Routine Maintenance

Routine maintenance is minimal as follows:

- A. Periodically (150 hours of operation) check to see that pumped liquid is going through stuffing box and out to wet well or drain.
- B. Check that the gland bolts have not loosened.

Seal Removal

General

Stop the driver and lock out the power so that the driver cannot accidentally start.

DANGER

Check with proper electrical testing equipment to be certain all electrical power to the driver and accessories associated with the pump is disconnected.

Single Inside Seal

- A. Disconnect piping to seal gland (431).
- B. Loosen the seal housing capscrews (431A).
- C. Raise the gland (431) and loosen the setscrews securing the retaining ring to the sleeve.
- D. Use the adjusting nut and lower the impellers until they rest on the bowl seats.
- E. Loosen the shaft coupling. Remove the driver shaft (19), or VHS motor if one-piece head shaft, or spacer from the four-piece flanged coupling if VSS motor.
- F. Remove the seal gland (431) and stationary seat (456A).
- G. Remove the seal rotating seat (456).
- H. Inspect all parts of the seal. If any parts show signs of wear, the complete seal should be replaced.

Single Outside Seal

- A. Disconnect piping to seal gland (431).
- B. Loosen the retainer ring setscrews.
- C. Use the adjusting nut to lower the impellers until they rest on the bowl seats.
- D. Loosen the shaft coupling. Remove the driver shaft (19), or VHS motor if one-piece head shaft,

or spacer from the four-piece flanged coupling if VSS motor.

- E. Loosen the capscrews securing the gland (431) to the seal housing. Remove the seal rotating assembly and the gland which contains the stationary seat.
- F. Inspect all parts of the seal. If any parts show signs of wear, the complete seal should be replaced.

Cartridge Seal

- A. Disconnect piping to seal gland (431).
- B. Install plastic tabs, setting devices, or pull cord to retain proper spring tension
- C. Loosen the collar set screws.
- D. Use the adjusting nut to lower the impellers until they rest on the bowl seats.
- E. Loosen the shaft coupling. Remove the driver shaft (19), or VHS motor if one-piece head shaft, or spacer from the four-piece flanged coupling if VSS motor.
- F. Loosen the capscrews securing the gland (431) to the seal housing. Remove the seal assembly.
- G. Inspect all parts of the seal. If any parts show signs of wear, the complete seal should be replaced.

Assembly Tools

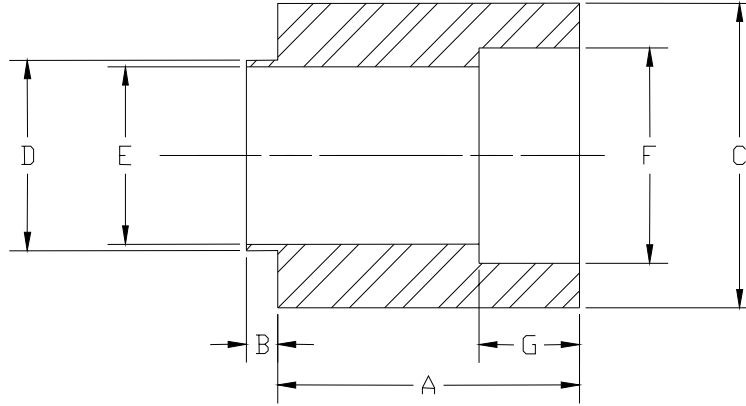
The following tools are to facilitate installation and disassembly of the pump shaft (shaft locating tool) and impeller (collet driver). These tools are available for purchase from your Layne/Verti-Line representative or they can be made according to the dimensions given below.

Shaft Locating Tool

The shaft locating tool sets the proper position of moving parts in relation to the stationary parts of the bowl assembly.

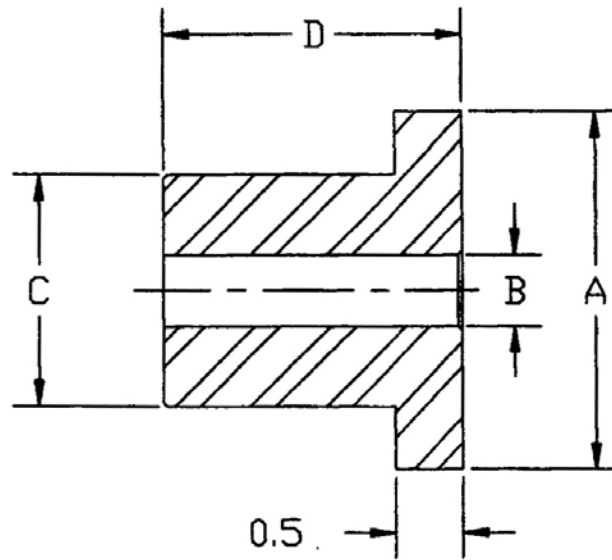
Collet Driver

The collet drive is used to drive the split collet between the impeller & pump shaft and when reversed, can be used to loosen the collet when disassembling the bowl assembly.



Collet Driver

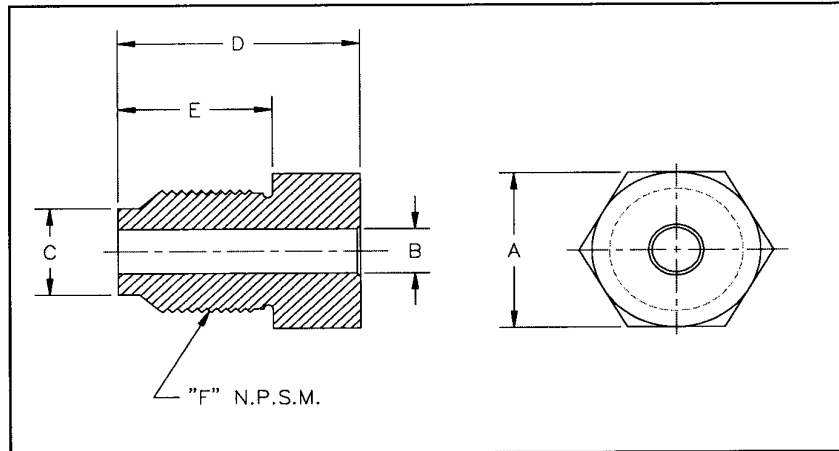
Shaft Size	A	B	C	D	E	F	G
1	2 3/4	1/4	2 1/4	1 5/32	1 1/32	1 11/32	1
1 3/16	2 3/4	1/4	2 1/4	1 11/32	1 7/32	1 17/32	3/4
1 1/2	4 1/4	3/4	2 11/16	1 27/32	1 17/32	2 1/32	5/8
1 7/16	3	5/16	2 7/8	1 21/32	1 15/32	2 1/32	3/4
1 11/16	3	5/16	3	1 29/32	1 23/32	2 7/32	1
1 15/16	3	5/16	3 1/4	2 1/4	1 31/32	2 31/32	3/4
2 3/16	6	5/16	4	2 1/2	2 7/32	2 13/16	3/4



Shaft Locating Tool

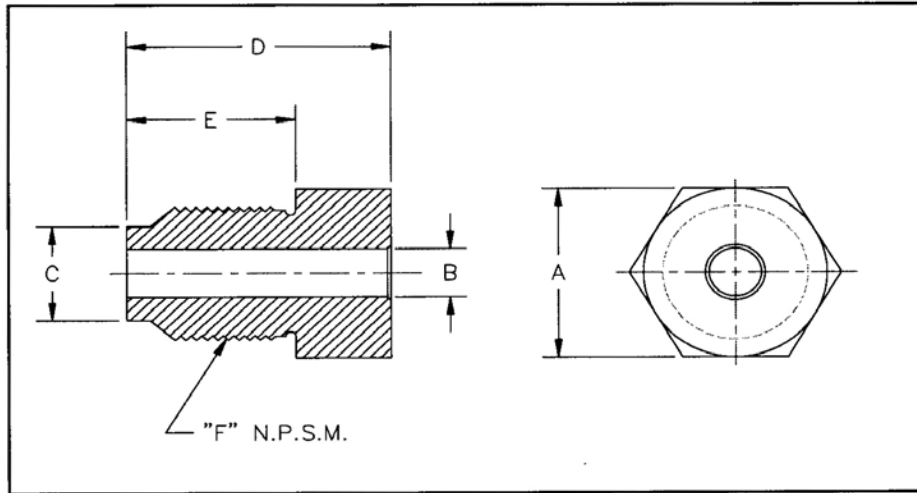
Pump Size	Shaft Dia.	Bolt Size	A	B	C	D
6EM	1	3/8 X 3/4	2 1/2	7/16	7/8	1 3/16
7EM	1	3/8 X 2	2 1/2	7/16	7/8	1 7/16
8EM	1 3/16	3/8 X 2	2 1/2	7/16	7/8	1 1/2
10EM	1 7/16	3/8 X 2 1/4	2 1/2	7/16	1 11/16	1 3/4
11EM	1 7/16	3/8 X 2 1/2	2 1/2	7/16	1 11/16	1 15/16
11EH	1 7/16	3/8 X 2 1/2	2 1/2	7/16	1 11/16	1 15/16
12EM	1 11/16	3/8 X 2 1/2	2 1/2	7/16	1 11/16	2 1/8
13EH	1 11/16	3/8 X 2 1/2	2 1/2	7/16	1 11/16	2 1/8
14EM	1 15/16	3/8 X 3 1/2	2 1/2	7/16	1 11/16	2 5/16
15EH	1 15/16	3/8 X 3 1/2	2 1/2	7/16	1 11/16	2 5/16
17EM	2 3/16	3/8 X 2 1/2	2 1/2	7/16	1 1/2	2 1/8
17EH	2 3/16	3/8 X 2 1/2	2 1/2	7/16	1 1/2	2 1/8

Shaft Locating Tools



Pump Size	Shaft Dia.	Bolt Size	A	B	C	D	E	F
6DRELC	1.000	1/2 x 5	2.00	0.53	1.00	2.50	1.50	1 - 11-1/2
6DRMC	1.000	1/2 x 5	2.00	0.53	1.00	2.50	1.50	1 - 11-1/2
6RKLC	1.000	1/2 x 5	2.00	0.53	1.00	2.50	1.50	1 - 11-1/2
6RKHC	1.000	1/2 x 5	2.00	0.53	1.00	2.50	1.50	1 - 11-1/2
6GM	1.000	1/2 x 5	2.00	0.53	1.00	2.50	1.50	1 - 11-1/2
6GH	1.000	1/2 x 5	2.00	0.53	1.00	2.50	1.50	1 - 11-1/2
7CL	1.000	1/2 x 5	2.00	0.53	1.00	2.50	1.50	1 - 11-1/2
7CM	1.000	1/2 x 5	2.00	0.53	1.00	2.50	1.50	1 - 11-1/2
7CEH	1.000	1/2 x 5	2.00	0.53	1.00	2.50	1.50	1 - 11-1/2
8URHC	1.188	1/2 x 5	2.00	0.53	1.12	2.50	1.50	1-1/2 - 11-1/2
8RL	1.188	1/2 x 5	2.00	0.53	1.00	2.50	1.50	1 - 11-1/2
8RM	1.188	1/2 x 5	2.00	0.53	1.00	2.50	1.50	1 - 11-1/2
8RH	1.188	1/2 x 5	2.00	0.53	1.00	2.50	1.50	1 - 11-1/2
8TM	1.188	1/2 x 5	2.00	0.53	1.12	2.50	1.50	1-1/2 - 11-1/2
8TH	1.188	1/2 x 5	2.00	0.53	1.12	2.50	1.50	1-1/2 - 11-1/2
10RKLC	1.500	1/2 x 5	2.50	0.53	1.44	2.62	1.5	2 - 11-1/2
10RKHC	1.500	1/2 x 5	2.50	0.53	1.44	2.62	1.5	2 - 11-1/2
10RKHS	1.500	1/2 x 5	2.50	0.53	1.44	2.62	1.5	2 - 11-1/2
10RKEH	1.500	1/2 x 5	2.50	0.53	1.44	2.62	1.5	2 - 11-1/2
10TLC	1.500	1/2 x 5	2.50	0.53	1.44	2.62	1.5	2 - 11-1/2
10THC	1.500	1/2 x 5	2.50	0.53	1.44	2.62	1.5	2 - 11-1/2
10FHM	1.688	1/2 x 5	2.00	0.53	1.00	2.50	1.50	1 - 11-1/2
10FHH	1.688	1/2 x 5	2.00	0.53	1.00	2.50	1.50	1 - 11-1/2
12RKBL	1.688	1/2 x 5	2.50	0.53	1.44	2.62	1.50	2 - 11-1/2
12RKBM	1.688	1/2 x 5	2.50	0.53	1.44	2.62	1.50	2 - 11-1/2
12RKBH	1.688	1/2 x 5	2.50	0.53	1.44	2.62	1.50	2 - 11-1/2
12RKBEH	1.688	1/2 x 5	2.50	0.53	1.44	2.62	1.50	2 - 11-1/2
12TLC	1.688	1/2 x 5	2.50	0.53	1.44	2.62	1.50	2 - 11-1/2
12THC	1.688	1/2 x 5	2.50	0.53	1.44	2.62	1.50	2 - 11-1/2
12RL	1.938	1/2 x 5	2.00	0.53	1.00	2.50	1.50	1 - 11-1/2
12RM	1.938	1/2 x 5	2.00	0.53	1.00	2.50	1.50	1 - 11-1/2
12RH	1.938	1/2 x 5	2.00	0.53	1.00	2.50	1.50	1 - 11-1/2
12FHL	1.938	1/2 x 5	2.00	0.53	1.00	2.50	1.50	1 - 11-1/2
12FHM	1.938	1/2 x 5	2.00	0.53	1.00	2.50	1.50	1 - 11-1/2
12FHH	1.938	1/2 x 5	2.00	0.53	1.00	2.50	1.50	1 - 11-1/2
12DEH	1.688	1/2 x 5	2.50	0.53	1.44	2.62	1.50	2 - 11-1/2

Shaft Locating Tools



Pump Size	Shaft Dia.	Bolt Size	A	B	C	D	E	F
13CL	1.688	1/2 x 5	2.50	0.53	1.44	2.62	1.50	2 - 11-1/2
13CM	1.688	1/2 x 5	2.50	0.53	1.44	2.62	1.50	2 - 11-1/2
14RL	2.188	1/2 x 5	2.00	0.53	1.00	2.50	1.50	1 - 11-1/2
14RM	2.188	1/2 x 5	2.00	0.53	1.00	2.50	1.50	1 - 11-1/2
14RH	2.188	1/2 x 5	2.00	0.53	1.00	2.50	1.50	1 - 11-1/2
14FHM	2.188	1/2 x 5	2.00	0.53	1.00	2.50	1.50	1 - 11-1/2
14FHH	2.188	1/2 x 5	2.00	0.53	1.00	2.50	1.50	1 - 11-1/2
16GM	2.188	1/2 x 5	3.00	0.53	1.88	3.00	1.50	2-1/2 - 8
18GL	2.188	1/2 x 5	3.00	0.53	1.88	3.00	1.50	2-1/2 - 8
18GM	2.188	1/2 x 5	3.00	0.53	1.88	3.00	1.50	2-1/2 - 8

SECTION 6 REPAIR PARTS

Ordering Parts

When ordering parts, give pump serial number, size, model number, a complete description, and item number of each part. Refer to the drawings and parts list in the drawing section of this manual. You may order parts from your local Layne/Verti-Line distributor. Consult your local telephone yellow pages under "Pumps" for the office nearest you.

You may also contact Layne/Verti-Line directly as follows:

Layne/Verti-Line
3601 Fairbanks Avenue
Kansas City, KS 66106
Phone (913) 371-5000
Fax (913) 748-4030

Recommended Spare Parts

Refer to Table 1 for a list of recommended spare parts. This list is for normal duty. Where severe conditions exist or minimum down time is critical additional quantities and those items indicated should be considered.

Table 1 Recommended Spare Parts

Item	Description	Quantity
13	Sleeve, Top Drive Shaft	1
15	Packing, Set	1
17A	Bushing, Packing Box	1
26	Bearings, Line shaft, set	1
29	Sleeve, Line shaft, set	1
31	Couplings, Set	1
34	Bearing, Top Bowl	1
35	Bearing, Inter Bowl, set	1
41	Bearing, Suction	1
50	Bearing Connector, set	1
	Gasket, Set	1

Returning Parts

All materials or parts returned to the factory must have prior approval and a "Returned Goods Tag", listing the material to be returned and the reasons for the return. All material to be returned should be carefully

packaged to avoid damage in route from rough handling or exposure to weather. Contact the factory for shipping instructions. All material is to be returned freight prepaid.

Layne/Verti-Line makes improvements on its products from time to time and reserves the right to furnish improved parts for repairs. A part that is received and is not identical in appearance, or has a different symbol from the original part may be interchangeable. Examine the part carefully before contacting your Layne/Verti-Line representative. The parts should never be returned to the factory without first obtaining proper authorization from your Layne/Verti-Line representative.

Predicted Life

The predicted life of parts subject to wear, shown in Table 2, is based on pumping liquid without abrasives, the pump operating at sold conditions and that proper maintenance is performed.

The actual life encountered for the specific parts may vary significantly as a result of the content of liquid pumped, maintenance performed, actual operating conditions and other factors.

Table 2 Predicted Life

Item	Description	Life (Yr.)
7	Discharge Head	20
13	Shaft Sleeve	5
15	Packing, Set	1
17	Packing Box	20
17A	Packing Box Bushing	10
19	Top Shaft	10
21	Top Column	20
23	Line shaft	10
25	Bearing Retainer	20
26	Line shaft Bearing	10
29	Shaft Sleeve	5
30	Bottom Column	20
31	Shaft Coupling	10
32	Pump Shaft	10
34	Top Bowl Bearing	10
35	Inter Bowl Bearing	10
36	Inter Bowl	20
36W	Bowl Wear Ring	5
38	Impeller	10
38W	Impeller Wear Ring	5
39	Collet	10
40	Suction Bell (Case)	20
41	Suction Bell Bearing	10
50	Connector Bearing	10
54	Discharge Case	20
55	Top Inter Bowl	20
58	Sand Collar	10

Service**Warranty Service**

For Warranty Service contact the facility from which your pump was shipped.

Shipping facility address:

Layne/Verti-Line
 3610 Fairbanks Avenue
 Kansas City, KS 66106
 Phone (913) 371-5000
 Fax: (913) 748-4030

Service After Warranty

For service after warranty on this pump or any other pumping equipment contact you local Layne/Verti-Line distributor or by contacting:

Pump Services Group, 1-800-648-PUMP

Or write:

Pump Services Group

Layne/Verti-Line
 3610 Fairbanks Avenue
 Kansas City, KS 66106
 Phone (913) 371-5000
 Fax: (913) 748-4030

TECHNICAL DATA

Table 1

Bowl Size	Shaft End Play (Inches)	
	At Full Diameter	At Minimum Diameter
6DRELC	.36	.36
6DRMC	.36	.36
6RKLC	.50	.50
6RKHC	.50	.50
6EM	.34	.80
6GM	.25	.25
6GH	.25	.25
7EM	.46	1.10
7CL	.25	.25
7CM	.25	.25
7CEH	.25	.25
8URCH	.44	.44
8RL	.375	RTF
8RM	.375	RTF
8RH	.375	RTF
8EM	.44	.80
8TM	.30	.30
8TH	.30	.30
10RKLC	.86	.86
10RKHC	.86	.86
10RKHS	.86	.86
10RKEH	.86	.86
10EM	.70	.78
10TLC	.44	.44
10THC	.44	.44
10FHM	.375	RTF
10FHH	.375	RTF
11EM	.75	1.07
11EH	.87	1.73
12RKBL	.70	.70
12RKBM	.70	.70
12RKBH	.70	.70
12RKBEH	.70	.70
12TLC	.50	.50
12THC	.50	.50
12EM	.99	1.17
12RL	.56	RTF
12RM	.56	RTF
12RH	.56	RTF

12FHL	.56	RTF
12FHM	.44	RTF
12FHH	.44	RTF
12DEH	1.00	1.00
13CL	.64	.64
13CM	.64	.64
13EH	.87	1.81
14RL	.70	RTF
14RM	.70	RTF
14RH	.70	RTF
14EM	1.00	1.30
14FHM	.56	RTF
14FHH	.56	RTF
15EH	.93	1.90
16GM	.44	.44
17EM	1.13	1.25
17EH	1.20	2.20
18GL	.38	.38
18GM	.38	.38

Table #2

Tube Tension Nut Torque Values	
Enclosing Tube Size	Required Torque
2	400 ft. lbs.
2 1/2	400 ft. lbs.
3	800 ft. lbs.
3 1/2	800 ft. lbs.
4	1200 ft. lbs.
5	1200 ft. lbs.

Table 3

Water Flush Packing Box Tube Tension Torque Values		
Tube Size	Installation and Removal Tool	Required Torque
2	MS1380A	400 ft. lbs.
2 1/2	MS1380A	400 ft. lbs.
3	MS1380B	800 ft. lbs.
3 1/2	MS1380B	800 ft. lbs.
4	MS1380C	1200 ft. lbs.
5	MS1380C	1200 ft. lbs.

Table 4

Impeller Position			
6DRELC	.187	12RKBL	.312
6DRMC	.187	12RKBM	.312
6RKLC	.250	12RKBH	.312
6RKHC	.125	12RKBEH	.312
6EM	.200	12TLC	.125
6GM	.125	12THC	.125
6GH	.125	12EM	.200
7EM	.200	12RL	.030
7CL	.125	12RM	.030
7CM	.125	12RH	.030
7CEH	.125	12FHL	.030
8URCH	.250	12FHM	.030
8RL	.030	12FHH	.030
8RM	.030	12DEH	.125
8RH	.030	13CL	.125
8EM	.200	13CM	.125
8TM	.125	13EH	.200
8TH	.125	14RL	.030
10RKLC	.437	14RM	.030
10RKHC	.437	14RH	.030
10RKHS	.437	14EM	.200
10RKEH	.437	14FHM	.030
10EM	.200	14FHH	.030
10TLC	.250	15EH	.200
10THC	.250	16GM	.125
10FHM	.030	17EM	.200
10FHH	.030	17EH	.200
11EM	.200	18GL	.125
11EH	.200	18GM	.125

Table 5

Shaft Diameter	Number of Turns				
	1	2	3	4	5
1	.07	.14	.21	.28	.35
1 1/4	.10	.20	.30	.40	.50
1 1/2	.10	.20	.30	.40	.50
1 11/16	.10	.20	.30	.40	.50
1 15/16	.10	.20	.30	.40	.50
2 3/16	.10	.20	.30	.40	.50

Table 6

Coupling Size	Torque (Ft. Lbs.)
1125	13
1625	26
2125	115
2625	115
2875	115
3125	115
3875	400
5000	550
6000	835
7250	835

Note: Dimension shown is the amount the impeller is to be raised above the bowl seat.

(1) Indicates inches to lowered from top most position.

Table 7

System Type	Grease	Oil
Non Potable	N.L.G.I. #2 Lithium base multi-purpose grease with a mineral based oil viscosity of 750-1050 SSU at 100°F and 75-82 SSU at 210°F.	High quality grade of non-detergent oil with an API/SAE rating 10W Rating
	Suggested Manufacturers: Atlantic Richfield- ARCO M/P #2 Gulf- Gulfcrown #2 Sinclair- Litholine M/P #2 Texaco- Marfak 958; M/P #2	Suggested Manufacturers: Mobil Sinclair Texaco
Potable	N.L.G.I. #2 meeting FDA regulation 178.3570 and has USDA Type H-1 and FDA approval for lubricants with incidental food contact.	USDA and FDA Approved
	Suggested Manufacturer: Chevron FM Grade 2 Ideal FG #2 Keystone Nevastone HT/AW2 Lubriplate FGL-2 Mobile FM Grade 2	Suggested Manufacturer: AMOCO White Mineral Oil No. 5 NF

Table 8

Bowl Size	Diametral Bowl and/or Impeller Wear Ring Clearance		Diametral Bowl Bearing Clearance (Inches)			
	Nominal	Replacement	Bronze		Rubber	
			Nominal	Replacement	Nominal	Replacement
6DRELC	.018	.024	.009	.013	N/A	N/A
6DRMC	.018	.024	.009	.013	N/A	N/A
6RKLC	.018	.024	.009	.013	N/A	N/A
6RKHC	.018	.024	.009	.013	N/A	N/A
6EM	.016	.022	.014	.018	N/A	N/A
6GM	.018	.024	.009	.013	N/A	N/A
6GH	.018	.024	.009	.013	N/A	N/A
7EM	.016	.022	.014	.018	N/A	N/A
7CL	.018	.024	.009	.013	N/A	N/A
7CM	.018	.024	.009	.013	N/A	N/A
7CEH	.018	.024	.009	.013	N/A	N/A
8URCH	.018	.024	.009	.013	N/A	N/A
8RL	.013	.018	.009	.013	N/A	N/A
8RM	.013	.018	.009	.013	N/A	N/A
8RH	.013	.018	.009	.013	N/A	N/A
8EM	.016	.022	.014	.018	N/A	N/A
8TM	.018	.024	.009	.013	N/A	N/A
8TH	.018	.024	.009	.013	N/A	N/A
10RKLC	.023	.031	.010	.014	N/A	N/A
10RKHC	.023	.031	.010	.014	N/A	N/A
10RKHS	.023	.031	.010	.014	N/A	N/A
10RKEH	.023	.031	.010	.014	N/A	N/A
10EM	.016	.022	.014	.018	.015	.020
10TLC	.023	.031	.010	.014	N/A	N/A
10THC	.023	.031	.010	.014	N/A	N/A
10FHM	.016	.022	.010	.014	.018	.023
10FHH	.016	.022	.010	.014	.018	.023
11EM	.016	.022	.014	.018	.015	.020
11EH	.016	.022	.014	.018	.015	.020

Table #8 (continued)

Bowl Size	Diametral Bowl and/or Impeller Wear Ring Clearance		Diametral Bowl Bearing Clearance (Inches)			
	Nominal	Replacement	Bronze		Rubber	
			Nominal	Replacement	Nominal	Replacement
12RKBL	.023	.031	.010	.014	N/A	N/A
12RKBM	.023	.031	.010	.014	N/A	N/A
12RKBH	.023	.031	.010	.014	N/A	N/A
12RKBEH	.023	.031	.010	.014	N/A	N/A
12TLC	.023	.031	.010	.014	N/A	N/A
12THC	.023	.031	.010	.014	N/A	N/A
12EM	.016	.022	.014	.018	.015	.020
12RL	.017	0.23	.010/.011	.015	.018	.023
12RM	.017	.023	.010/.011	.015	.018	.023
12RH	.017	.023	.010/.011	.015	.018	.023
12FHL	.017	.023	.010/.011	.015	.018	.023
12FHM	.017	.023	.010/.011	.015	.018	.023
12FHH	.017	.023	.010/.011	.015	.018	.023
12DEH	.023	.031	.010	.014	N/A	N/A
13CL	.023	.031	.010	.014	N/A	N/A
13CM	.023	.031	.010	.014	N/A	N/A
13EH	.016	.022	.014	.018	.015	.020
14RL	.017	.023	.010/.011	.015	.022	.027
14RM	.017	.023	.010/.011	.015	.022	.027
14RH	.017	.023	.010/.011	.015	.022	.027
14EM	.016	.022	.014	.018	.015	.020
14FHM	.017	.023	.010/.011	.015	.022	.027
14FHH	.017	.023	.010/.011	.015	.022	.027
15EH	.016	.022	.014	.018	.015	.020
16GM	.023	.031	.010/.011	.015	N/A	N/A
17EM	.024	.032	.014	.018	.017	.022
17EH	.024	.032	.014	.018	.017	.022
18GL	.023	.031	.010/.011	.015	N/A	N/A
18GM	.023	.031	.010/.011	.015	N/A	N/A

Table #9
Product Lubricated (Rubber Bearings)

Lineshaft Diameter	1	1-1/4	1-1/2	1-11/16	1-15/16	2-3/16
Sleeve OD	1-3/16	1-7/16	1-11/16	1-7/8	2-1/8	2-3/8
Box ID	1-15/16	2-3/16	2-7/16	2-5/8	2-7/8	3-1/8
Box Depth	1-5/8	1-5/8	1-5/8	1-5/8	1-5/8	1-5/8
No. Rings Packing	4	4	4	4	4	4
Size Packing	3/8	3/8	3/8	3/8	3/8	3/8

Enclosed Lineshaft-Oil Lubricated

Lineshaft Diameter	1	1-1/4	1-1/2	1-11/16	1-15/16	2-3/16
Tube Diameter	1-1/2	2	2-1/2	2-1/2	3	3

Enclosed Lineshaft-Water-Flush Lubricated (Bronze Bearings)

Lineshaft Diameter	1	1-1/4	1-1/2	1-11/16	1-15/16	2-3/16
Sleeve OD	1-3/16	1-7/16	1-11/16	1-7/8	2-1/8	2-3/8
Box ID	1-15/16	2-3/16	2-7/16	2-5/8	2-7/8	3-1/8
Box Depth	1-5/8	1-5/8	1-5/8	1-5/8	1-5/8	1-5/8
No. Rings Packing	4	4	4	4	4	4
Size Packing	3/8	3/8	3/8	3/8	3/8	3/8



Fig. #1



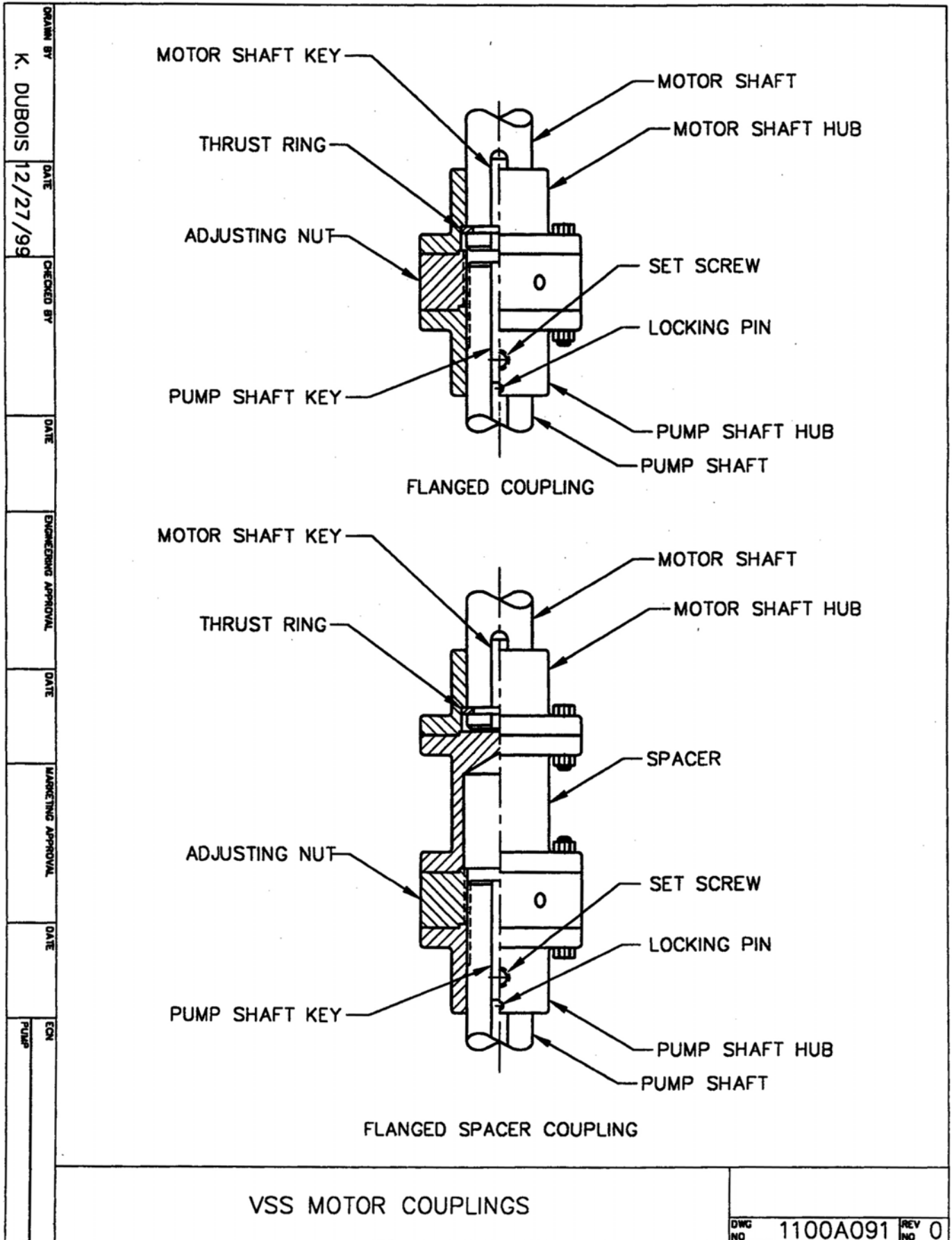
Fig. #2

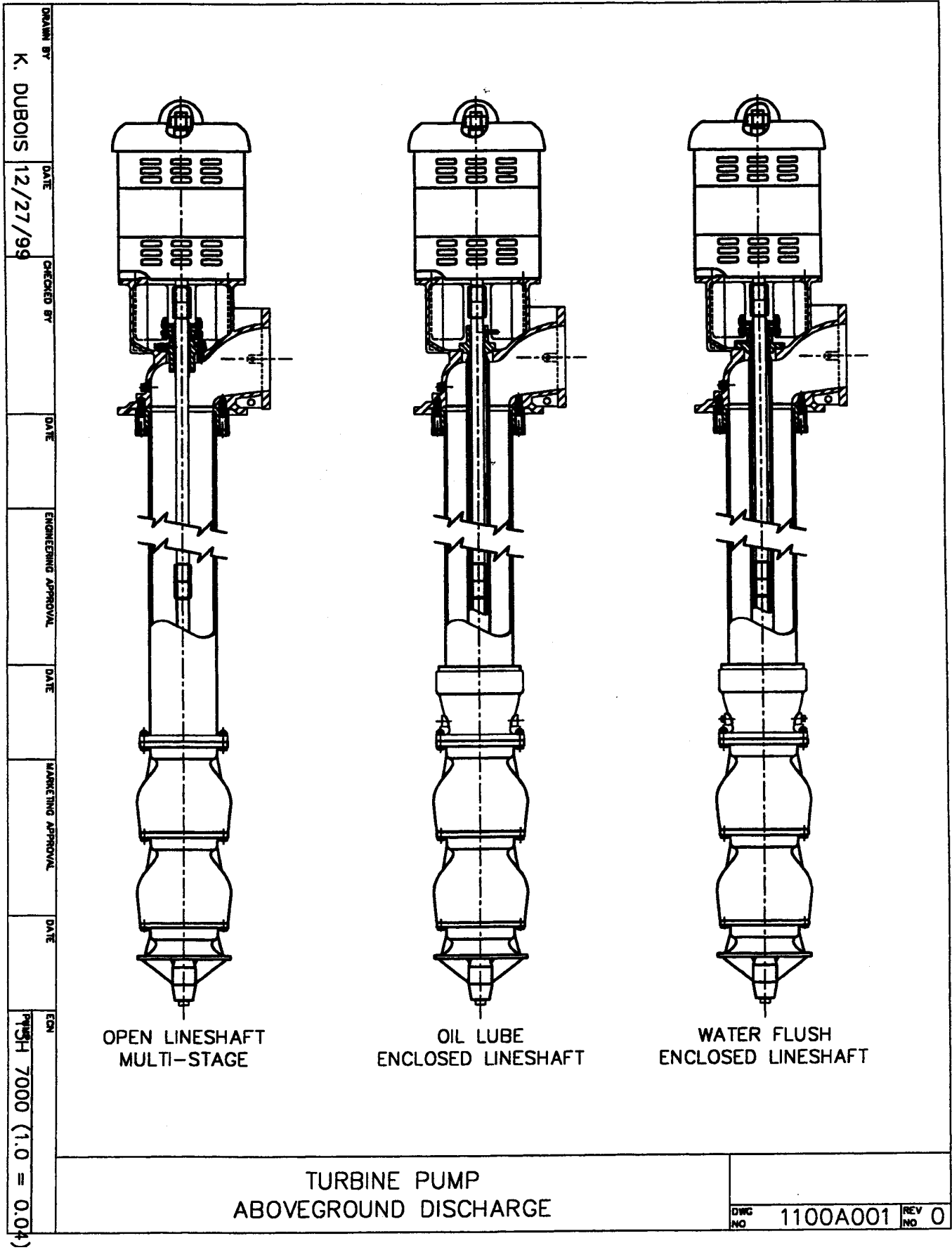


Fig. #3

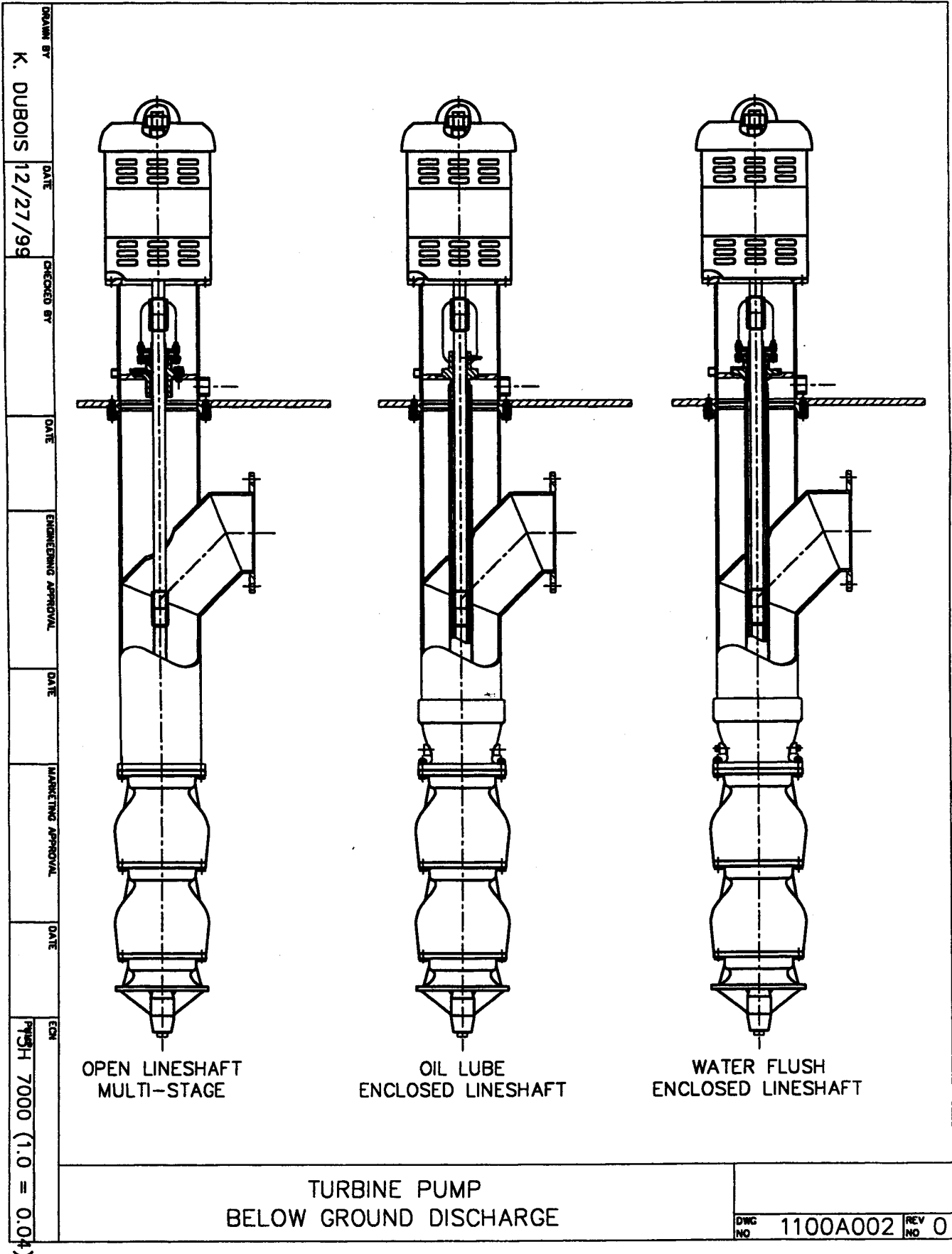


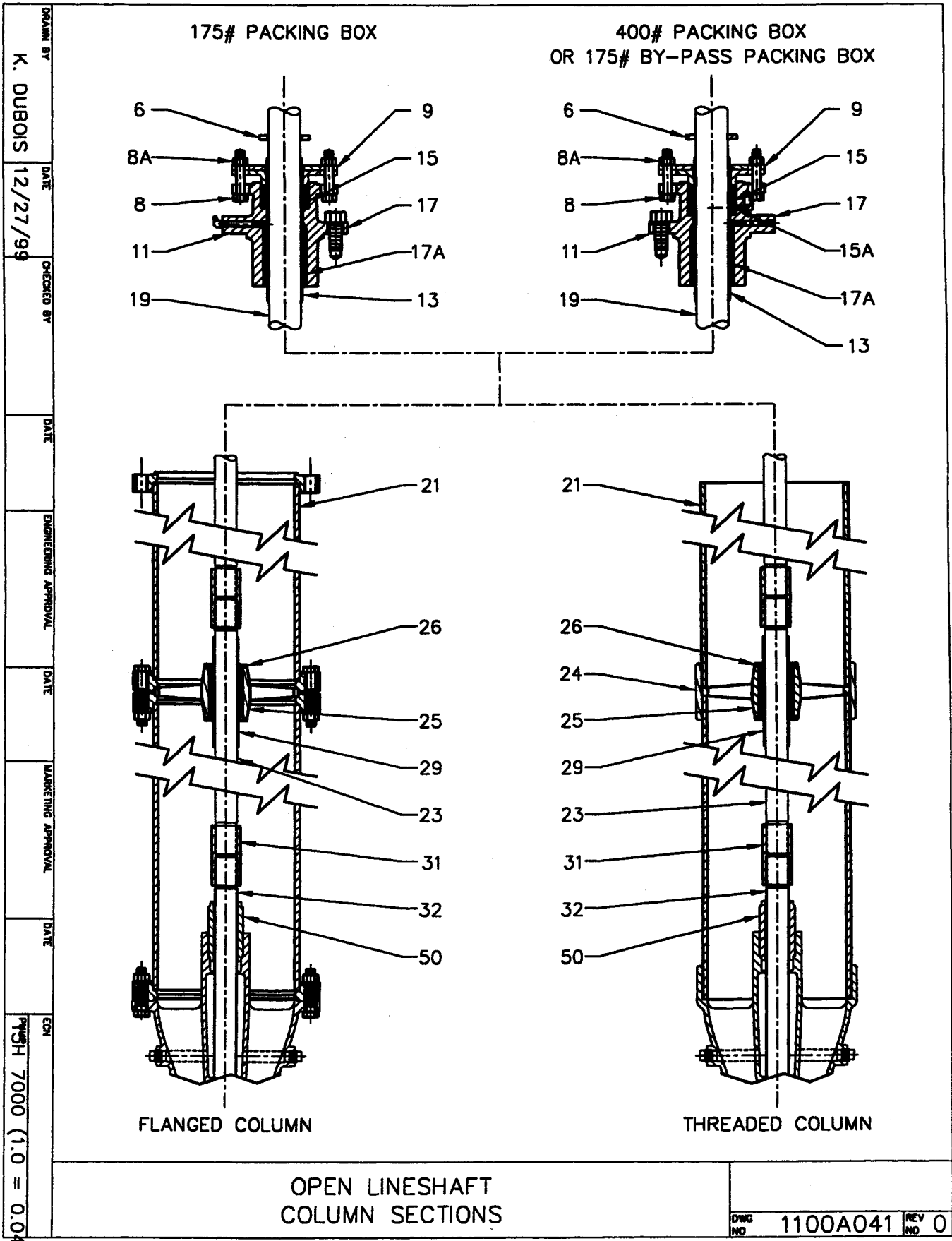
Fig. #4





ENH 7000 (1.0 = 0.04)





DRAWN BY
K. DUBOIS
 DATE
12/27/99
 CHECKED BY

 DATE

 ENGINEERING APPROVAL

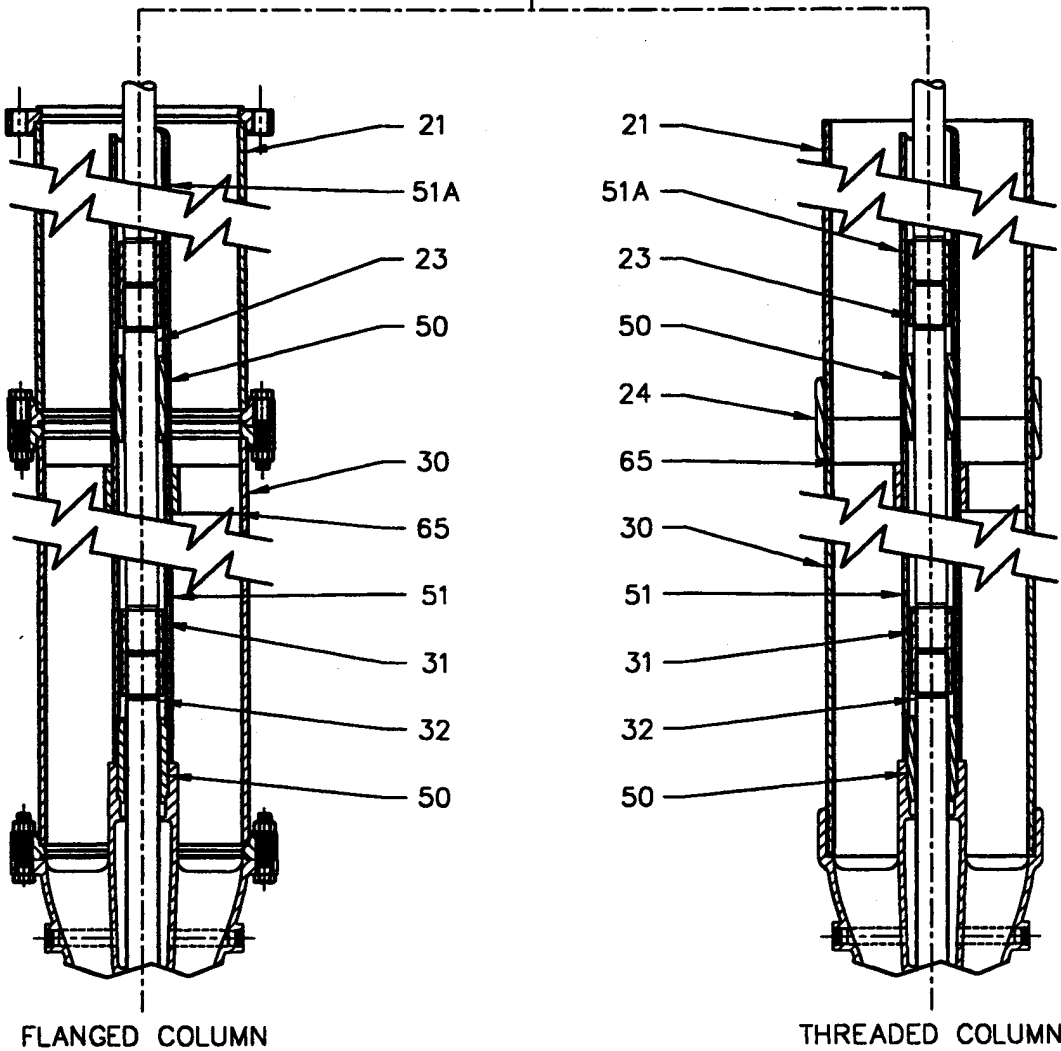
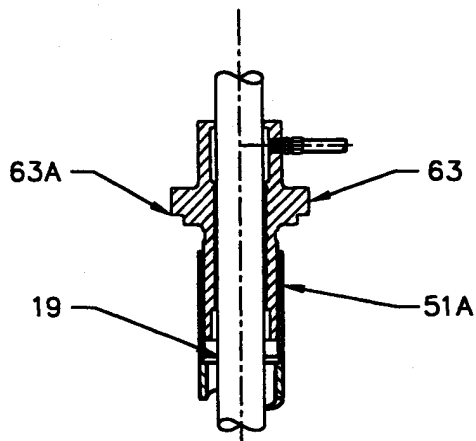
 DATE

 MARKETING APPROVAL

 DATE

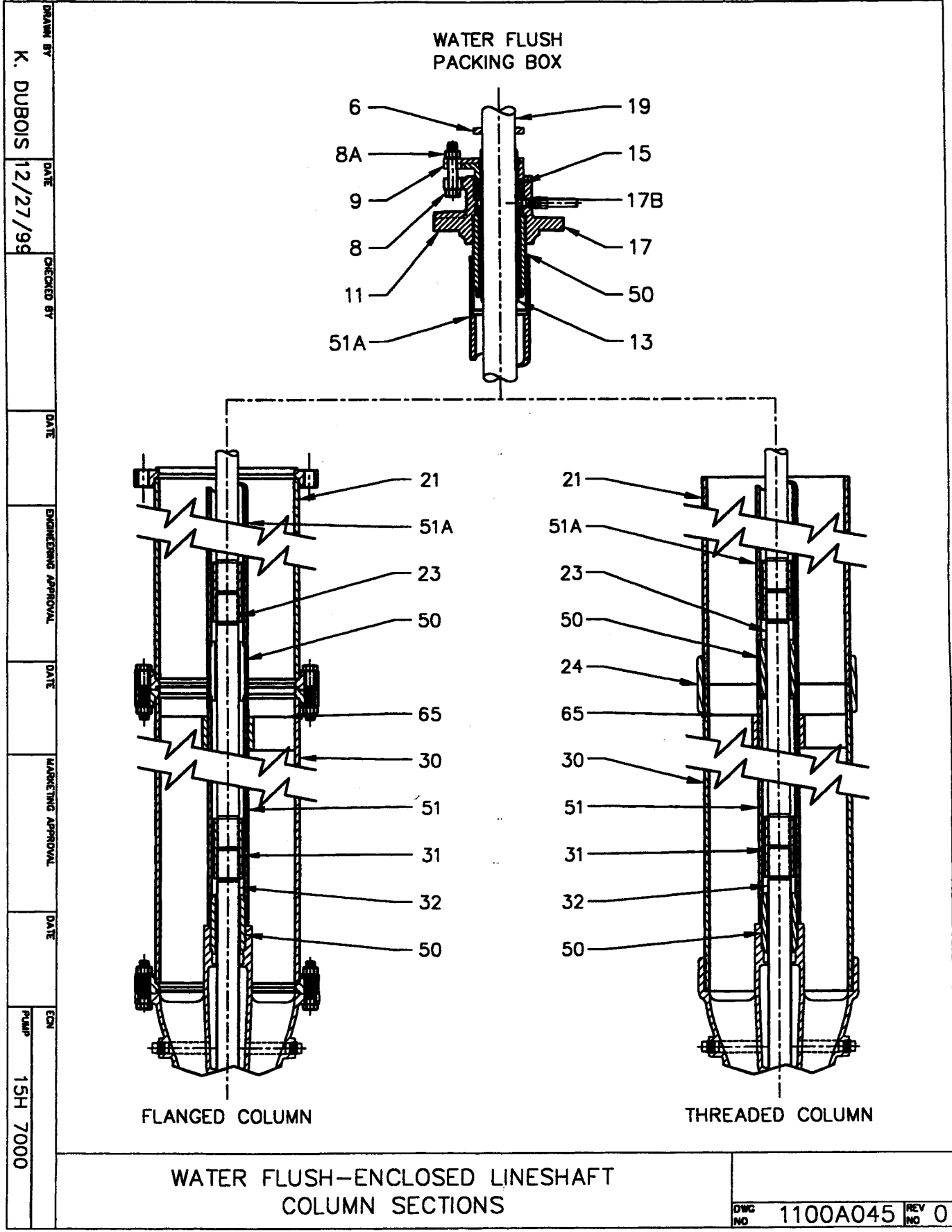
 ECN
 PUMP
15H 7000

OIL LUBRICATED TENSION NUT



OIL LUBRICATED-ENCLOSED LINESHAFT COLUMN SECTIONS

DWG NO **1100A043** REV NO **0**



DRAWN BY
K. DUBOIS

DATE
12/27/99

CHECKED BY

DATE

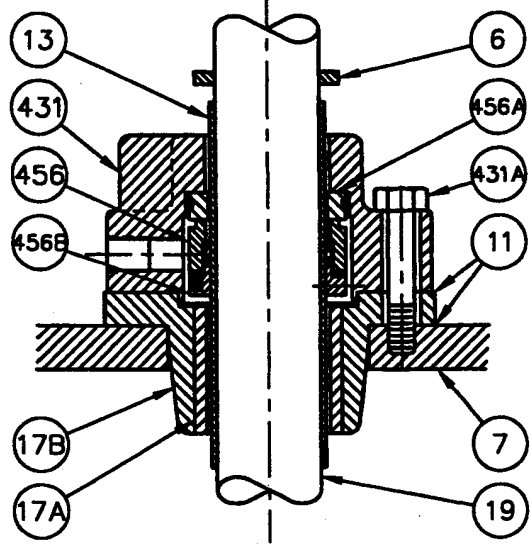
ENGINEERING APPROVAL

DATE

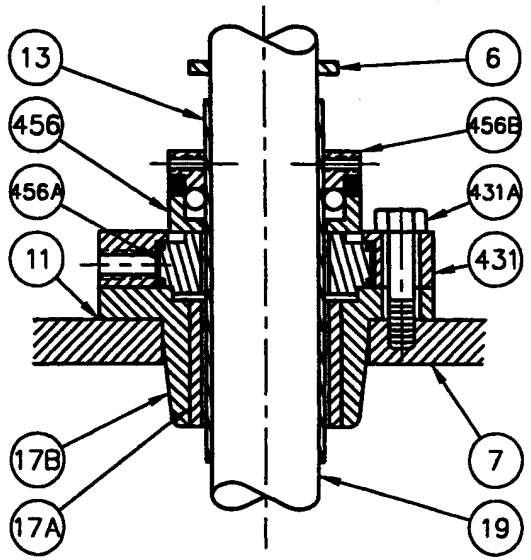
MARKETING APPROVAL

DATE

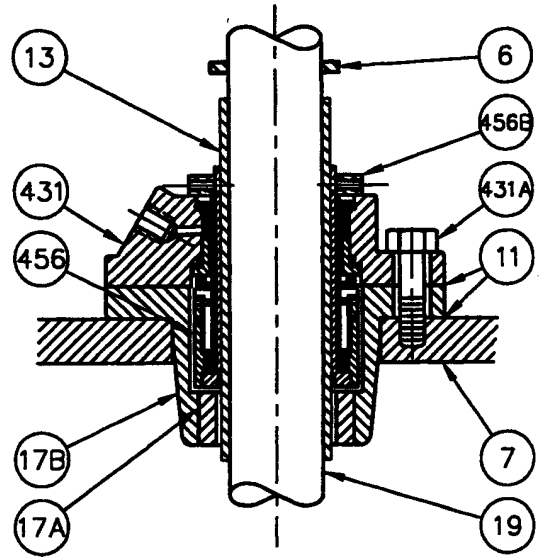
ECH
PUMP



BASIC MECHANICAL SEAL ASSEMBLY



OUTSIDE MECHANICAL SEAL ASSEMBLY



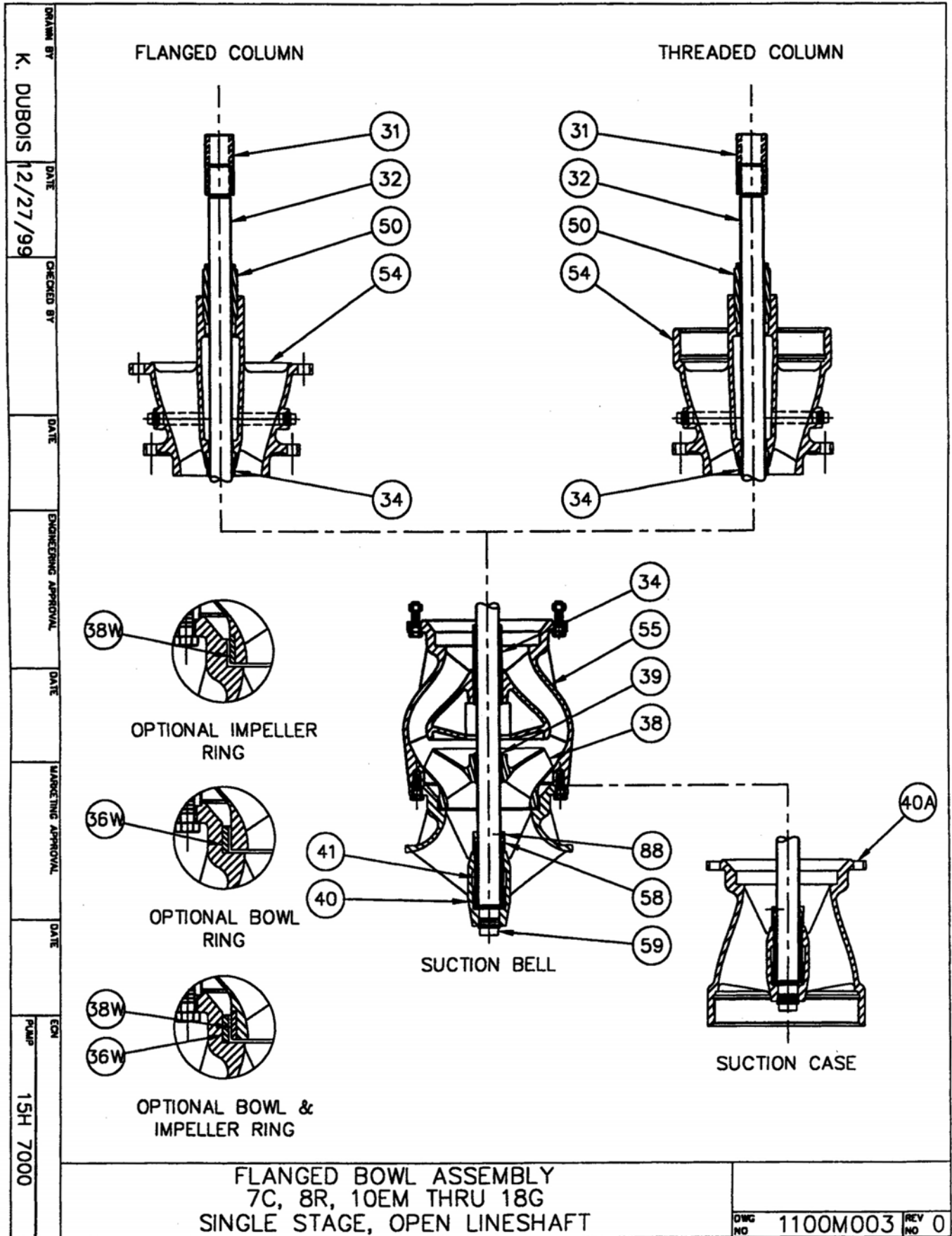
CARTRIDGE MECHANICAL SEAL ASSEMBLY

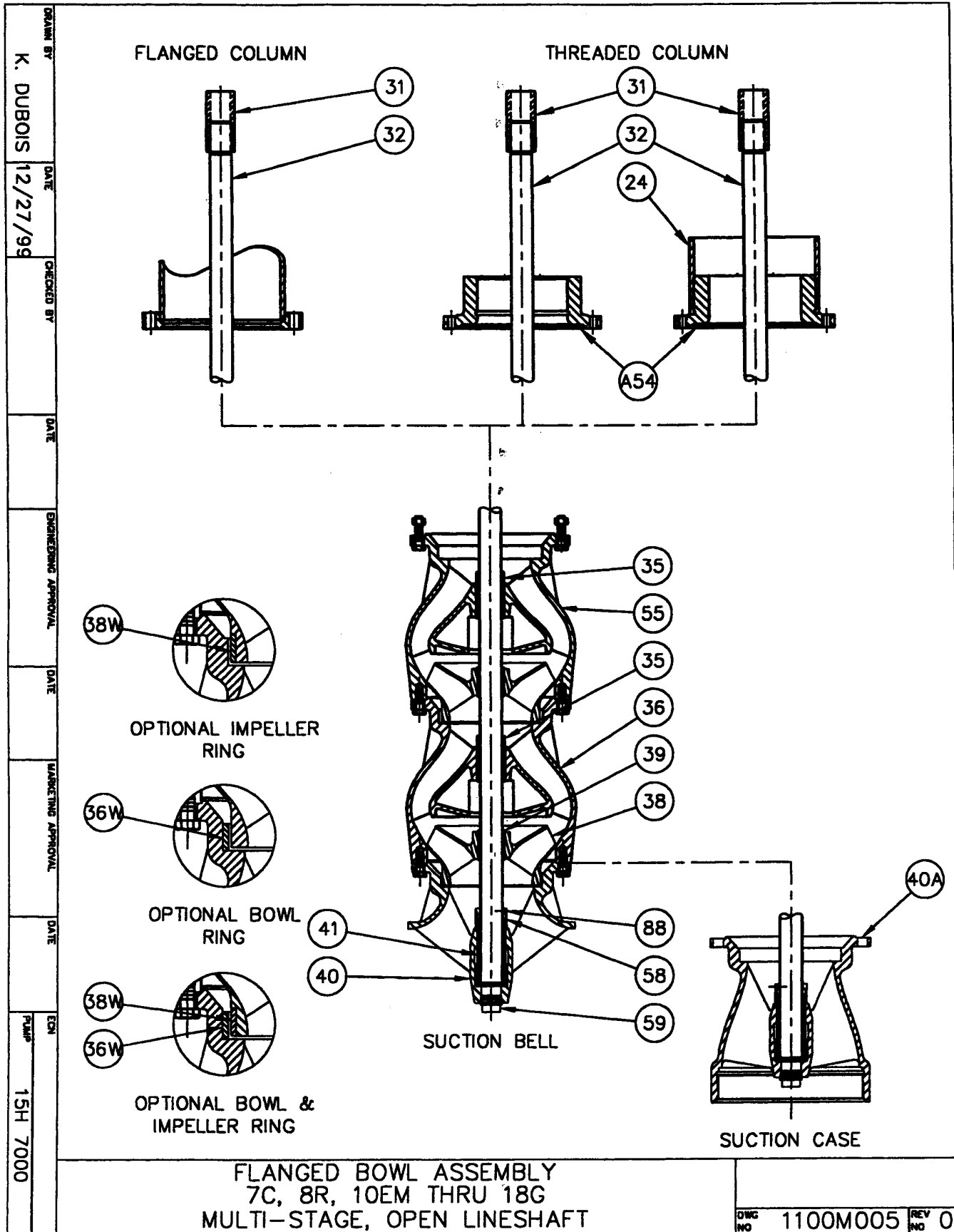
MECHANICAL SEALS

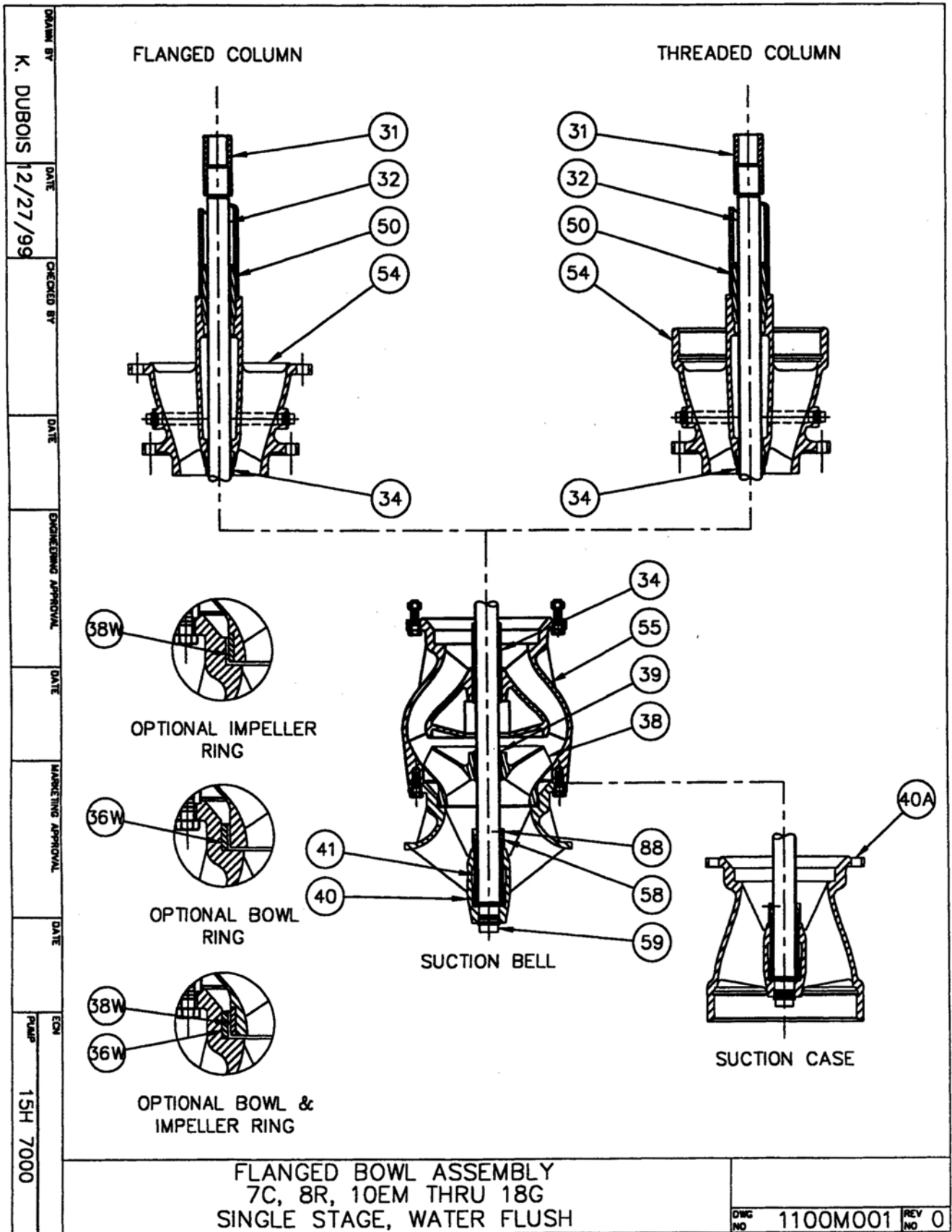
DMC NO 1100A081 REV NO 0

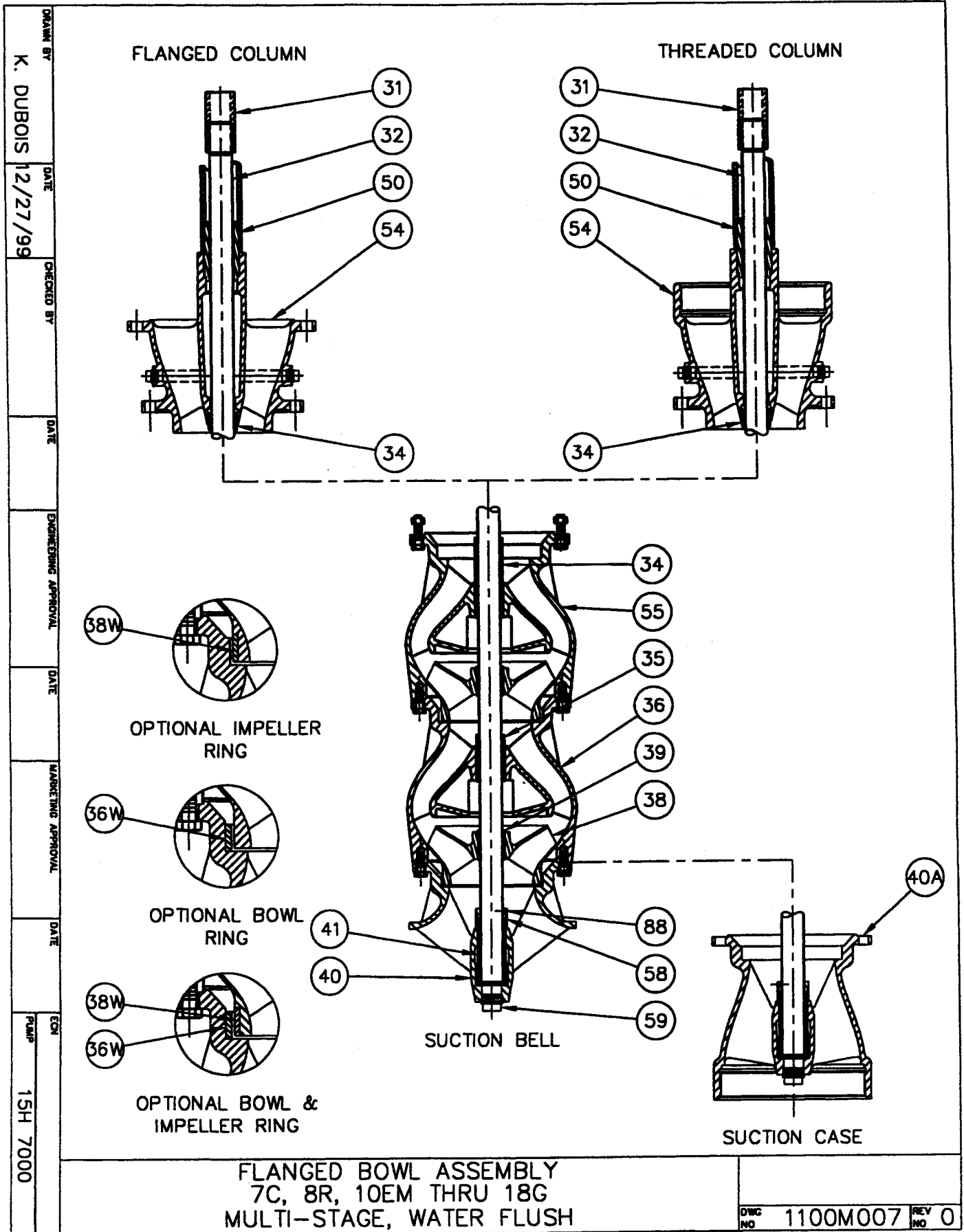
Column / Lineshaft / Seal Box Parts List

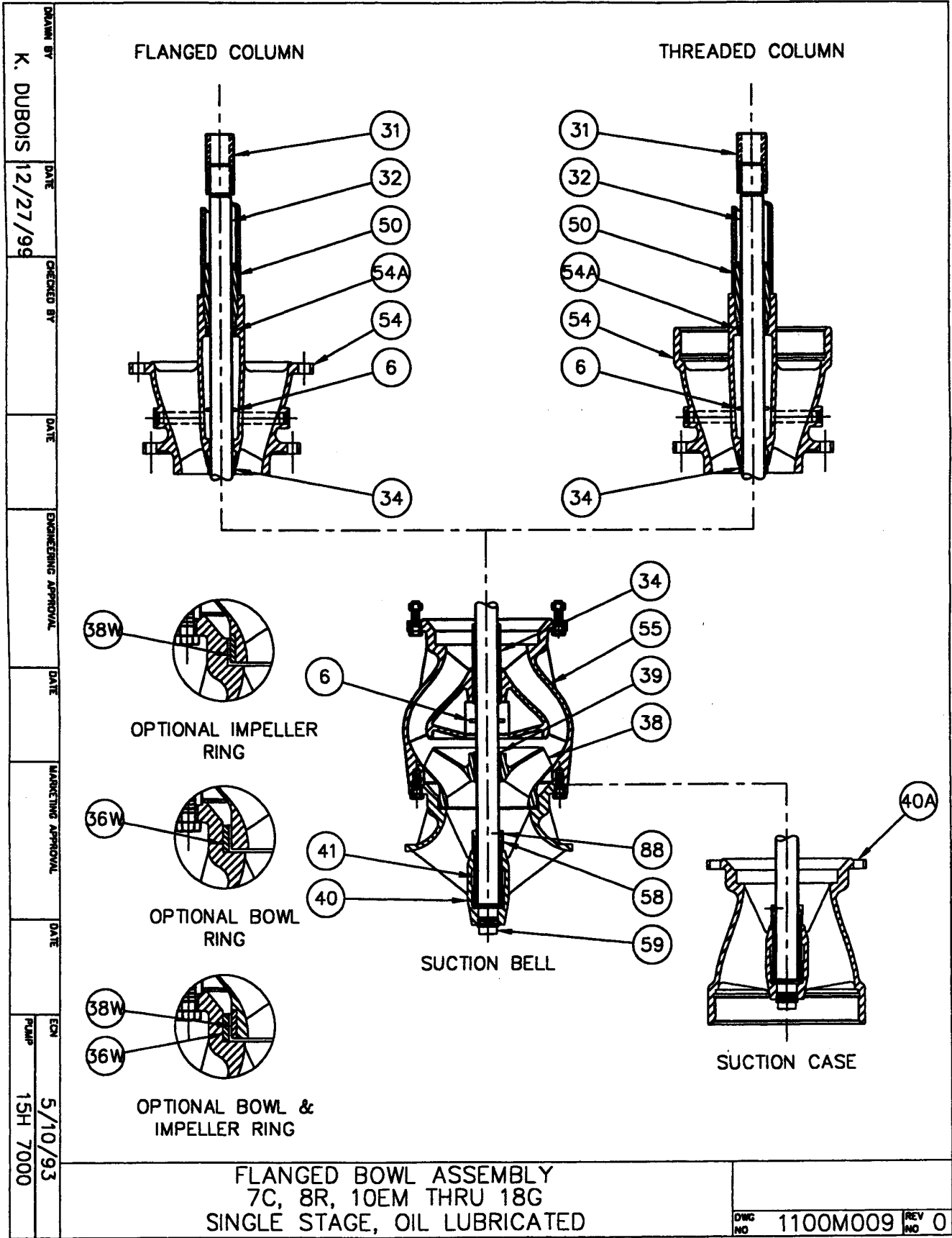
Part No.	Description
6	Slinger, Water
7	Discharge Head
8	Bolt, Gland
8A	Nut, Gland
9	Gland, Packing Box
11	Gasket, Packing Box
13	Sleeve, Top Shaft
15	Packing
15A	Ring, Water Seal
17	Packing Box
17A	Bushing, Packing Box
17B	Seal Housing
19	Shaft, Top
21	Column, Top
23	Lineshaft
24	Coupling, Threaded Column
25	Retainer, Bearing
26	Bearing, Lineshaft
29	Sleeve, Lineshaft
30	Column, Bottom
31	Coupling, Shaft
32	Shaft, Bowl
50	Bearing, Connector
51	Enclosing Tube, Bottom
51A	Enclosing Tube
63	Tension Nut, Enclosing Tube
63A	Gasket, Tension Nut
65	Stabilizer, Enclosing Tube
431	Gland, Mechanical Seal
431A	Capscrews, Packing Box
456	Seat, Mechanical Seal Rotating
456A	Seat, Mechanical Seal Stationary
456B	Retainer, Mechanical Seal







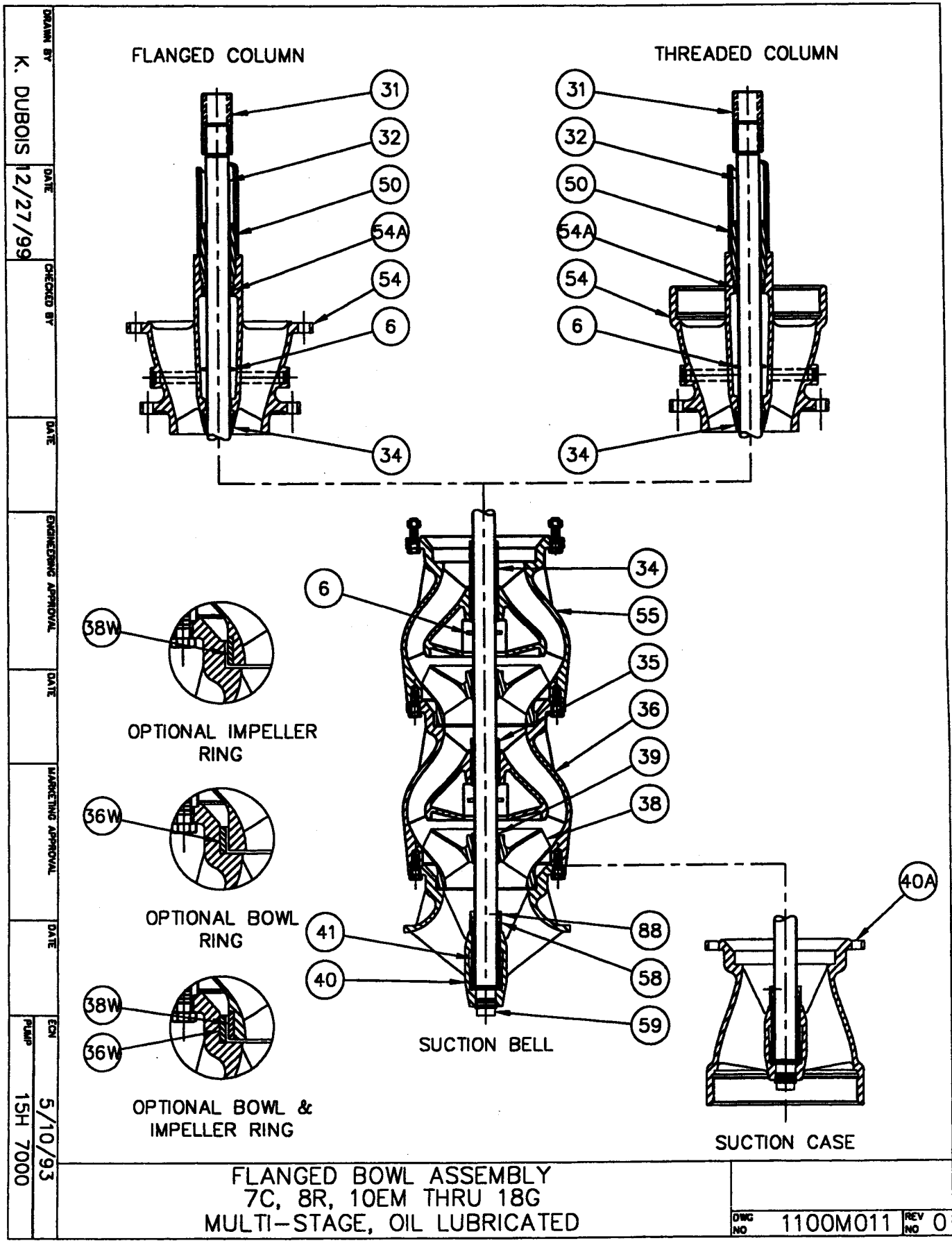




DRAWN BY: K. DUBOIS
 DATE: 12/27/99
 CHECKED BY:
 DATE:
 ENGINEERING APPROVAL:
 DATE:
 MARKETING APPROVAL:
 DATE:
 ENR: 5/10/93
 PUMP: 15H 7000

FLANGED BOWL ASSEMBLY
 7C, 8R, 10EM THRU 18G
 SINGLE STAGE, OIL LUBRICATED

DWG NO: 1100M009 REV NO: 0



DRAWN BY
K. DUBOIS
 DATE
12/27/99
 CHECKED BY

 DATE

 ENGINEERING APPROVAL

 DATE

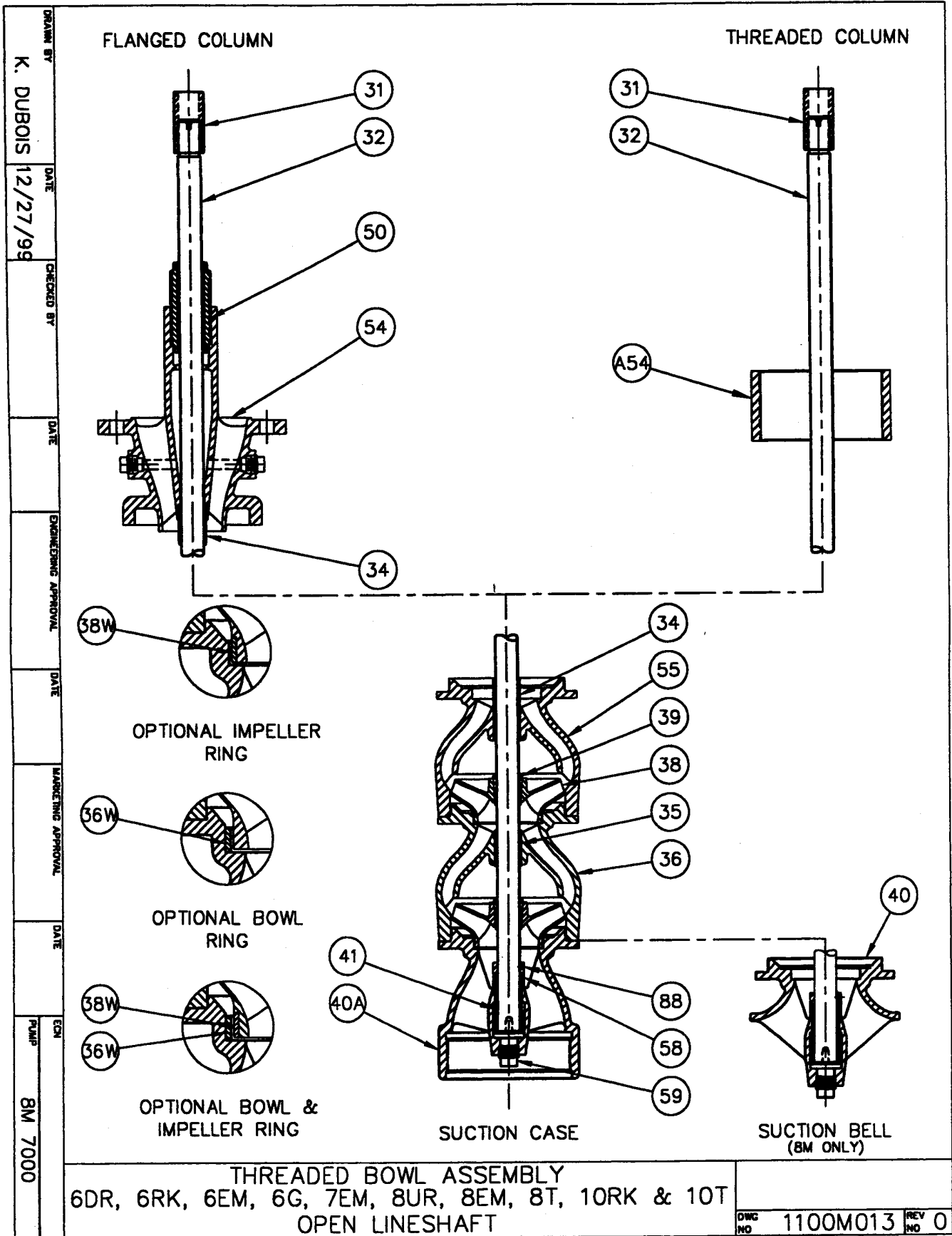
 MARKETING APPROVAL

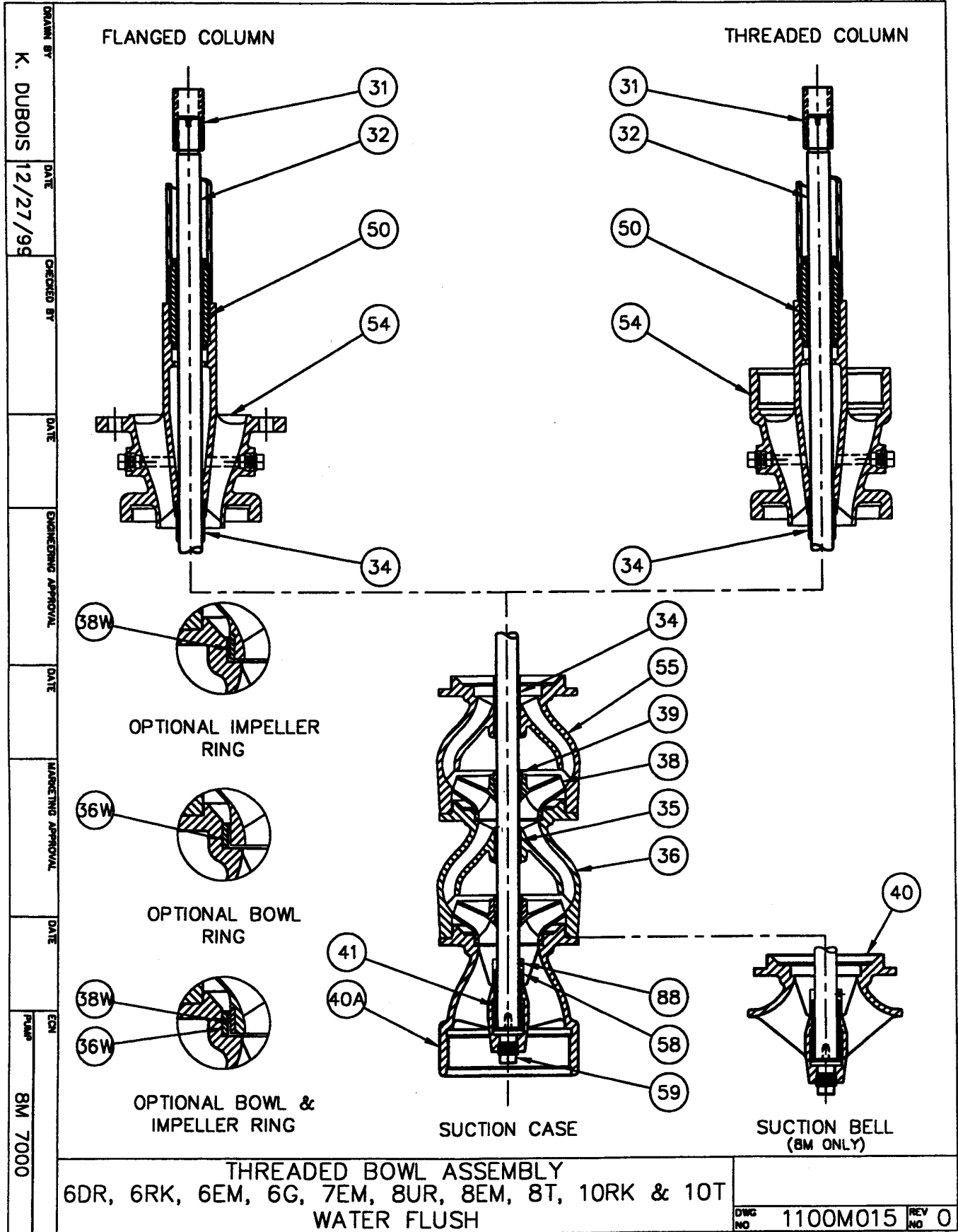
 DATE

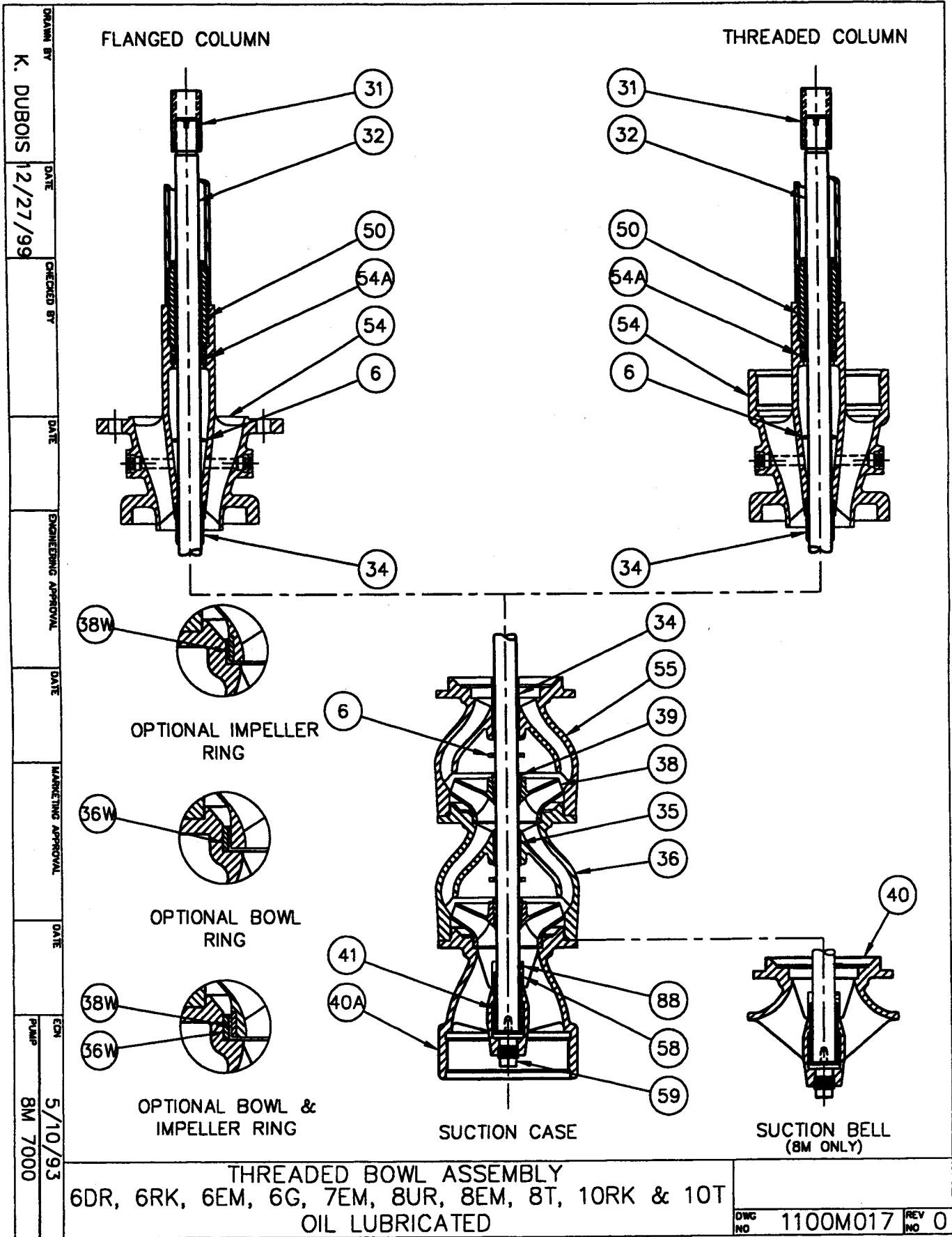
 ENR
 PUMP
15H 7000
 5/10/93

FLANGED BOWL ASSEMBLY
7C, 8R, 10EM THRU 18G
MULTI-STAGE, OIL LUBRICATED

DWG NO **1100M011** REV NO **0**

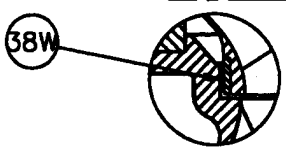
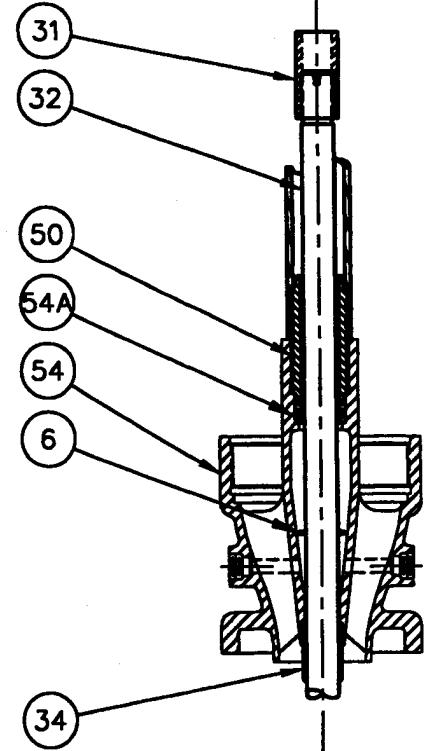
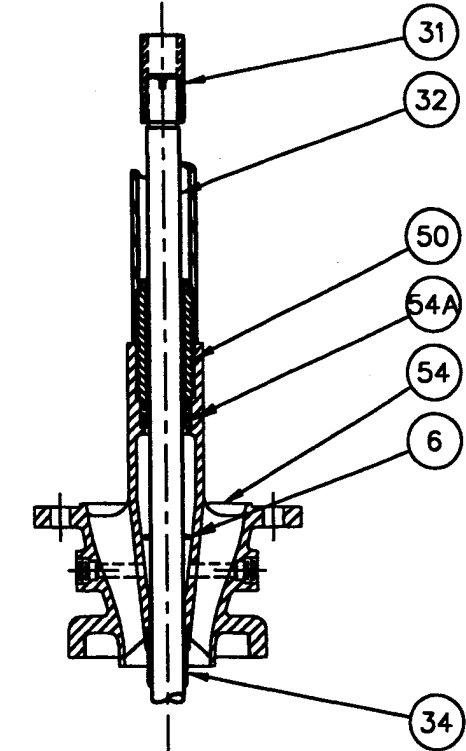




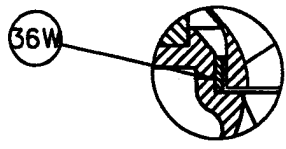


FLANGED COLUMN

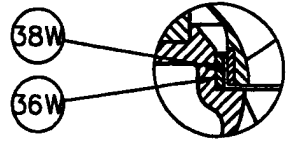
THREADED COLUMN



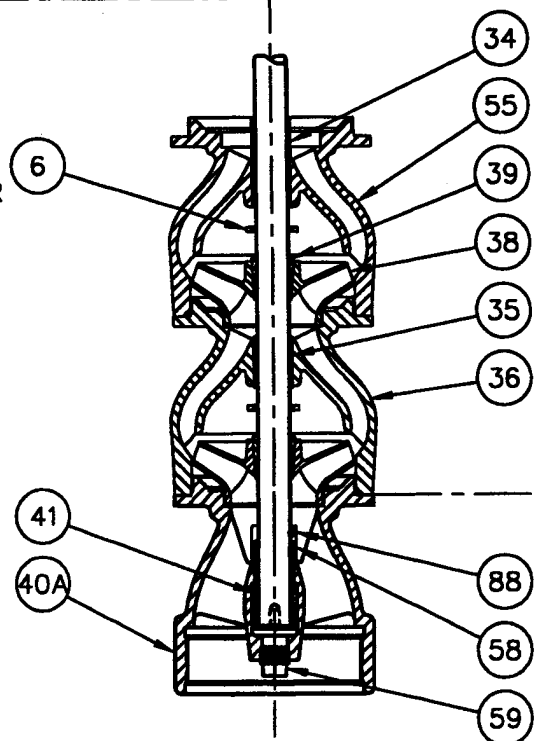
OPTIONAL IMPELLER RING



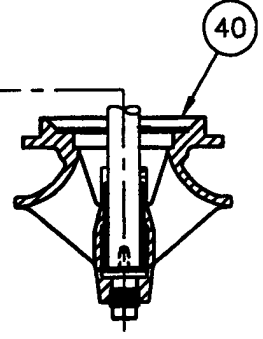
OPTIONAL BOWL RING



OPTIONAL BOWL & IMPELLER RING



SUCTION CASE



SUCTION BELL (BM ONLY)

THREADED BOWL ASSEMBLY
 6DR, 6RK, 6EM, 6G, 7EM, 8UR, 8EM, 8T, 10RK & 10T
 OIL LUBRICATED

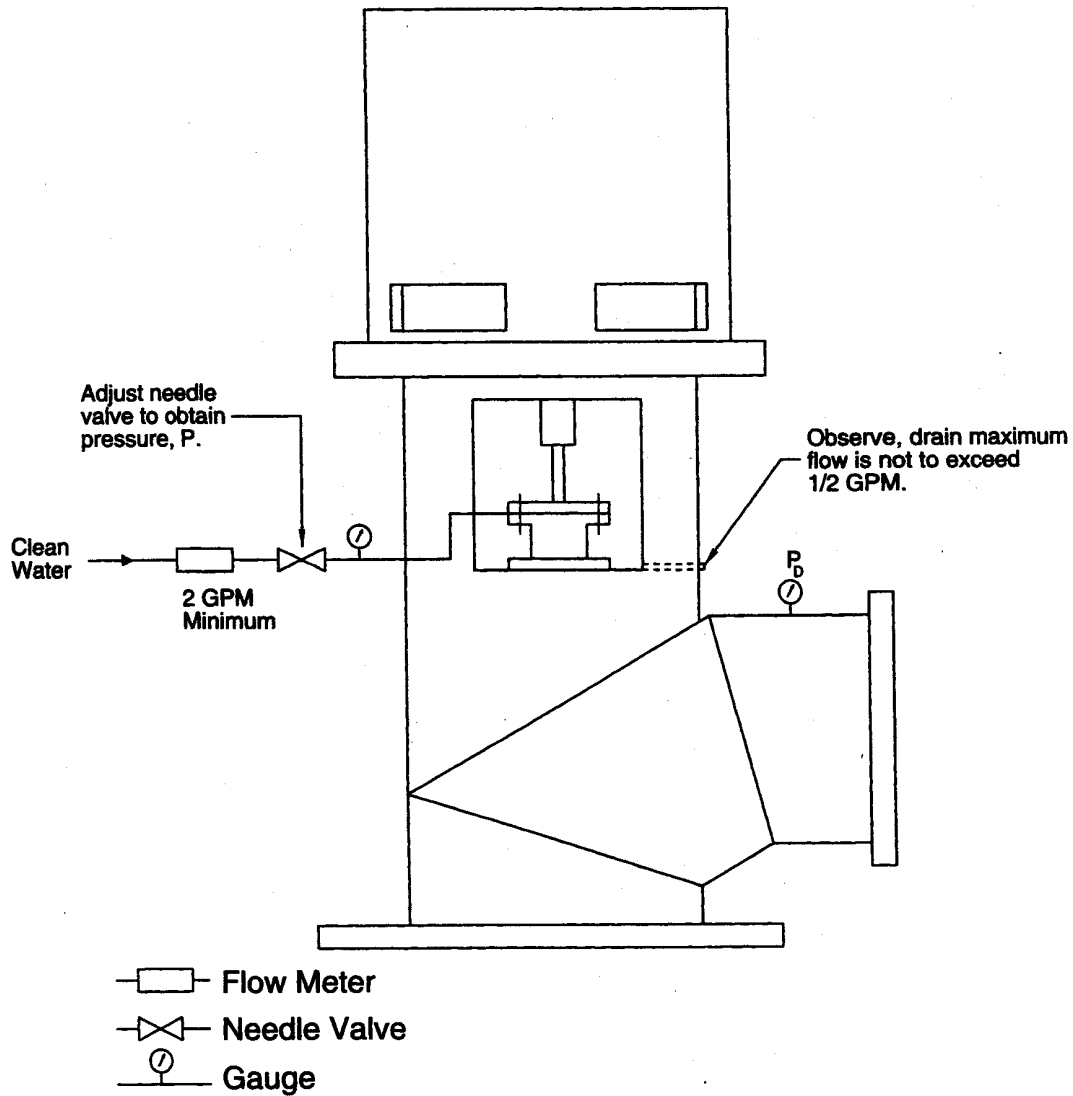
DWG NO 1100M017 REV NO 0

DRAWN BY
 K. DUBOIS
 DATE
 12/27/99
 CHECKED BY
 DATE
 ENGINEERING APPROVAL
 DATE
 MARKETING APPROVAL
 DATE
 PUMP
 BM 7000
 5/10/93

Bowl Assembly Parts List

Part No.	Description
6	Deflector, water
31	Coupling, Shaft
32	Shaft, Bowl
34	Bearing, Top Bowl
35	Bearing, Intermediate Bowl
36	Bowl, Intermediate
36W	Wear Ring, Bowl
38	Impeller
38W	Wear Ring, Impeller
39	Collet, Impeller
40	Suction Bell
40A	Suction Case
41	Bearing, Suction Bowl
50	Bearing, Connector
54	Discharge Case
54A	Lip Seal
A54	Adapter, Column
55	Bowl, Top Intermediate
58	Sand Collar
59	Plug, Suction Bowl
88	Set Screw, Sand Collar

Water Flush System (Only for pump with packing)



P_D = Pressure at discharge

$P = 3 \text{ psi for each 10 ft. of pump setting} + P_D + 5 \text{ psi}$

Example: 70 ft. setting
 $P_D = 52 \text{ psi}$

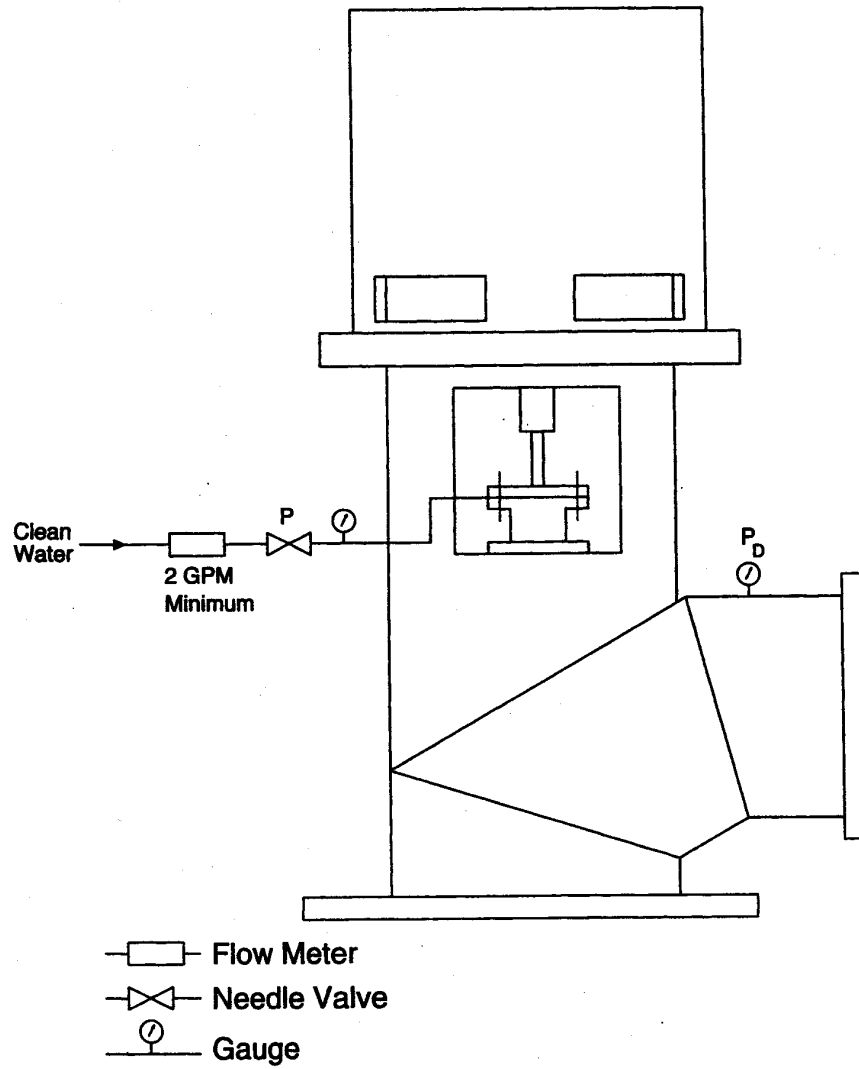
$$P = 3 \times \frac{70}{10} + 52 + 5$$

$$= 78 \text{ psi}$$

- Note: (1) Flush water is recommended at pump at all times, whether pump is operating or not.
 (2) Solenoid valves are not recommended.

Fig. #7

Water Flush System (Only for pump with mechanical seal)



P_D = Pressure at discharge

$P = 3 \text{ psi for each 10 ft. of pump setting} + P_D + 5 \text{ psi}$

Example: 70 ft. setting

$$P = 3 \times \frac{70}{10} + 52 + 5$$

$$= 78 \text{ psi}$$

- Note: (1) Flush water is recommended at pump at all times, whether pump is operating or not.
 (2) Solenoid valves are not recommended.

Fig. # 8

Open Lineshaft Water Vent System

(Only for pump with mechanical seal)

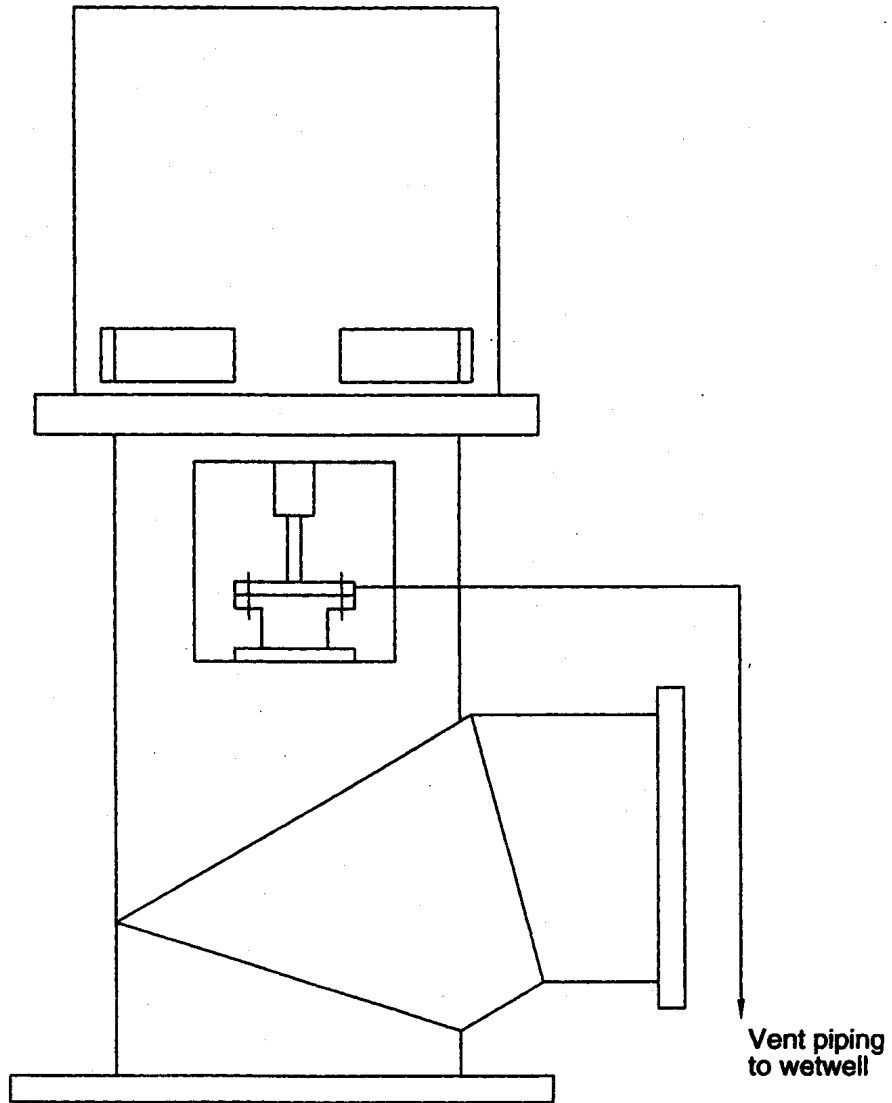


Fig. #9

THIS PAGE INTENTIONALLY LEFT BLANK

