

**AURORA ACCESSORIES**

WATTS BALANCING VALVE

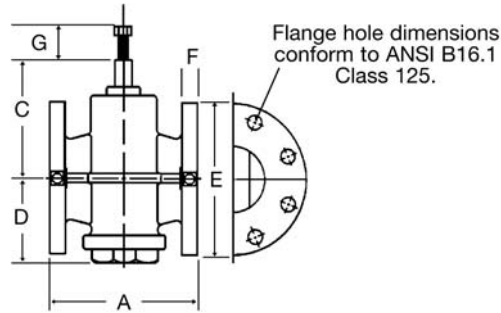

MODEL	SIZE	A	C	D	E	F	G	WT
CSM-81-F	2-1/2" Flange End	7.50 (191)	5.13 (130)	3.94 (99)	7.00 (178)	0.69 (17)	2.50 (64)	29.5 (13.4)
CSM-81-F	3" Flange End	8.00 (203)	5.44 (137)	4.19 (106)	7.50 (191)	0.75 (19)	2.50 (64)	39 (17.7)
CSM-81-F	4" Flange End	9.00 (229)	6.50 (165)	4.94 (124)	9.00 (229)	0.94 (24)	2.50 (64)	61.5 (27.9)
CSM-81-F	5" Flange End	10.50 (267)	7.75 (197)	6.00 (153)	10.00 (254)	1.00 (25)	2.50 (64)	88 (39.9)
CSM-81-F	6" Flange End	10.50 (267)	7.75 (197)	6.00 (153)	11.00 (279)	1.00 (25)	2.50 (64)	100 (45.4)
CSM-81-F	8" Flange End	11.50 (292)	9.19 (233)	6.50 (165)	13.50 (343)	1.13 (28)	2.50 (64)	172 (78)

Flow control and measurement valve of the plug type design. Cast iron body and plug with Teflon stem seat.

**NOTES:**

1. All dimensions in inches (mm), lbs (kg)
2. Dimensions may vary plus minus 1/8 (3)
3. Maximum working pressure: 175 psi (12 Bar)
4. Maximum working temperature 250 deg F (121 deg C)
5. For additional information visit [www.wattsreg.com](http://www.wattsreg.com)