

8" Suction Trap



Applications

- Protects against debris from entering pump
- Mounts directly onto Berkeley "LTH"/"LTM" (3 and 5 HP) and Sta-Rite "D" Medium/High Head units
- For use in residential and commercial systems

Features

- Trap may be cleaned at the pump eliminating the need to retrieve unit from reservoir for servicing
- Unit is ready for operation. No pea gravel required
- High flow design allows capacities up to 170 gpm with minimal friction loss
- Top-access cover with easy removable wing-type fasteners
- Large capacity cast iron body designed for minimum frequency maintenance intervals
- Corrosion proof stainless steel basket construction provides long life duty
- .103" basket perforations maximize filtering capability while minimizing friction loss
- Heavy-duty O-Ring equipped cover prevents air leaks
- Trap body provides additional water reserve for faster pump priming
- Adjustable base support
- 3" NPT suction connection
- Trap may be retrofitted to any existing or remote location**
- Installs in minutes

** PKG. 76 Cast Iron Flange adapts trap to 3" NPT for remote installations (not illustrated; sold separately).



Specifications

Ordering Part Number: PKG 98

Overall Shipping Weight: 46 lbs.

Friction Loss:

.5 psi	1 psi	2 psi	3 psi	4 psi
60 gpm	90 gpm	120 gpm	150 gpm	170 gpm

Dimensions

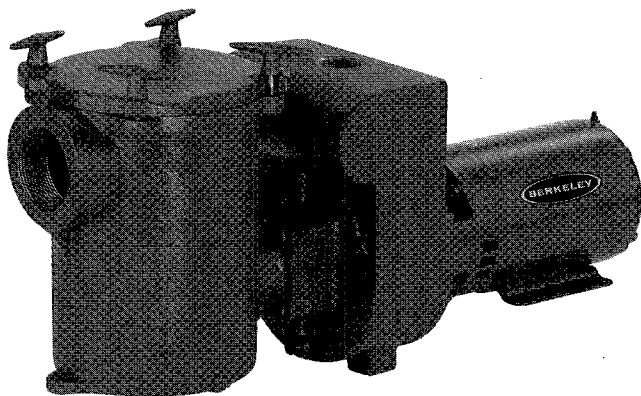
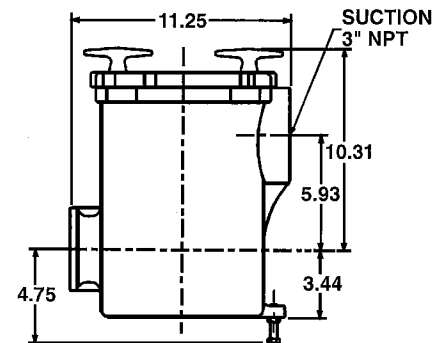

PKG 98 - 8" Trap (mounted on Berkeley LTH self-priming pumps)



Member of
Hydraulic
INSTITUTE

RELAX,
IT'S A BERKELEY™