

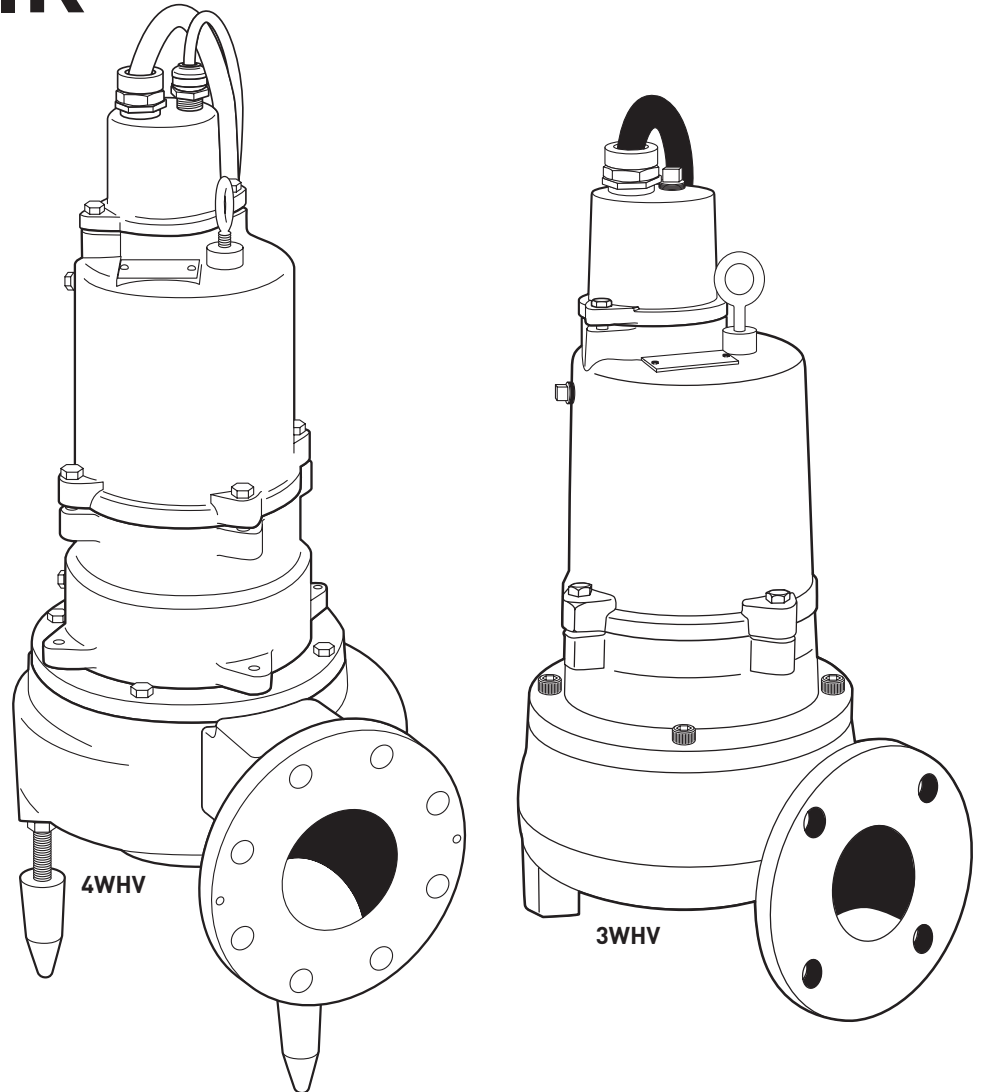

MYERS®



MODELS 3WHV, V3WHV, 3WHR, 4WHV, V4WHV and 4WHR **SUBMERSIBLE SOLIDS HANDLING PUMPS**

INSTALLATION AND SERVICE MANUAL

For use with product built with Regal-Beloit motor.



NOTE! To the installer: Please make sure you provide this manual to the owner of the equipment or to the responsible party who maintains the system.

SAFETY WARNINGS:

Before Installation: This manual contains important information for the safe use of this product. Read this manual completely and follow the instructions carefully. Reasonable care and safe methods relating to the installation and operation of this product should be practiced. Check local codes and requirements before installation.

DANGER: Risk of Electrical Shock or Electrocutation. May result in serious injury or death or fire hazard. Installer must disconnect all electrical sources prior to installation, handling or servicing. Only qualified personnel may install this system. NFPA 70/National Electric Code (NEC) or local codes must be followed. System must be properly grounded according to NEC. Do not lift pump by power cord.

DANGER: Biohazard Risk. Once wastewater source has been connected to system, Biohazard Risk exists. Installer(s) and/or service personnel must use proper Personal Protective Equipment and follow handling procedures per OSHA 29 CFR 1910.1030 when handling equipment after wastewater source has been connected to system.

DANGER: Risk of Asphyxiation. Installer(s) and/or service personnel must use proper Personal Protective Equipment and follow OSHA 29 CFR 1910.146 or OSHA 29 CFR 1926. Pump may be installed in a location classified by as a confined space.

DANGER: Risk of Fire or Explosion. Do not smoke or use open flames in or around this system. This system is intended for use in hazardous locations per NFPA 70 National Electric Code. Do not pump flammable liquids.

DANGER: Cutting Risk. Risk of serious cutting or amputation exists. Disconnect all power sources prior to servicing pump. Pump may start without warning.

Do not modify the cord and plug. When using the cord and plug, plug into a grounded outlet only. When wiring to a system control, connect the pump ground lead to the system ground.

Do not run the pump dry. Dry running can overheat the pump (causing burns to anyone handling it) and will void the warranty.

The pump normally runs hot. To avoid burns, allow it to cool for 30 minutes after shutdown before handling it.

Submersible sump pumps are not approved for use in swimming pools, recreational water installations, decorative fountains or any installation where human contact with the pumped fluid is common. Pump designed to be installed in a sump or wet location where drainage collects.

DO NOT THROW AWAY OR LOSE THIS MANUAL. Keep it in a safe place so that you may refer to it often for the continued safe operation of the product.

PUMP MODELS:

These instructions cover the installation and service of the 3WHV/V3WHV/3WHR and 4WHV/V4WHV/4WHR series of solids handling pumps and guide rail systems for the horizontal discharge models only. These models are designed for handling raw sewage and wastewater. Do not use for acid wastewater. The pumps have vortex, solids handling impellers. These pumps will pass 3" dia. solids and has a 3" or 4" std. flange discharge.

SEAL FAILURE (4WHV/ V4WHV/ 4WHR ONLY):

These pumps have a probe installed in the seal chamber, so that any leakage past the lower seal is detected. A red warning light at the control panel comes on if water enters the seal chamber. This is an indicator only and does not stop the motor. It warns that the seal should be replaced immediately. Longer running without seal replacement could damage motor. Motor must go to authorized service facility for seal replacement.

HEAT SENSOR (4WHV/ V4WHV/ 4WHR ONLY):

All single and three phase pumps have motor heat sensors that are externally wired to the control panel. Any motor temperature above the sensor rating will open the heat sensor and stop the motor. The sensor will automatically close upon cooling. It is important that the heat sensor wires and seal failure wires are connected at the panel terminal block. Warranty is void if wires are not connected or are jumped.

CAUTION: The single phase pumps with automatic heat sensor reset will restart without warning as the motor cools. Therefore, never do service work on the pump unless power supply is disconnected.

WARNING: On three phase pumps only qualified persons shall conduct services and installation of this pump. The pump must be wired by a qualified electrician, using an approved starter box and switching device.

CAUTION: Never pull pump or work on control box until incoming power is disconnected. Never run motor until green ground conductor is connected to a good outside ground. Never pull electrical cable to lift pump.

If the control panel is not located near the pump, consult wire gauge table for permissible wire gauge to run between the control panel and the junction box at the wet well.

CALIFORNIA PROPOSITION 65 WARNING:

▲ WARNING This product and related accessories contain chemicals known to the State of California to cause cancer, birth defects or other reproductive harm.

OIL FILLED MOTOR:

The motor chamber and seal chamber are dielectric oil-filled for good heat transfer and lubrication of bearings and seals. The motor requires no other lubrication. Oil level in the motor housing should be to the bottom of the oil fill plug with the pump in a vertical position. Do not overfill the motor housing since some space is required for oil expansion. Oil level in the seal chamber should be checked with the pump lying horizontally with the fill plug at the top. The oil level should be approximately 3/4" from the outside surface of the housing. Transformer oil should be used and may be purchased from your Myers® distributor.

AIR VENTING:

Upon initial filling of the wet well with the water, air may be trapped in the pump volute. To vent off this air, a 5/32" diameter hole is located in the volute. Be sure this vent hole is clean after any service work on pump.

**ELECTRICAL CONTROLS
(All Models)**

FLOAT SWITCH INSTALLATION

1. Level Controls are held by support bracket and cords are adjusted for proper depth.
 - a. Lower Turn-Off Control should be set so that pump stops when water level is about at the top of the volute.
 - b. First Turn-On Control is set to start pump when level is at height specified above pump.
 - c. Second Turn-On Control of a duplex pump system is set at height specified above first turn-on control.
 - d. Alarm Control is set about 6" to 12" above the highest Turn-On Control.
 - e. No control should be set above basin inlet invert.

MAKING ELECTRICAL CONNECTIONS

1. If control panel is mounted directly on basin top, the power and control wires are taken directly to control box and are sealed in the cord pallet with cord grip connectors.
2. If panel is installed remote from basin, the cords can be taken through a conduit to control panel, or junction box can be used in the basin to make connections. The Myers junction box has a built-in sealing connector to seal the outgoing wires. If other than Myers junction box is used, a separate sealing connector must be used where wires leave the basin.

CAUTION: If cords are taken directly through a conduit to control box, a seal fitting must be used at inlet of conduit to prevent gas vapors from getting to control box. This type of installation is generally not recommended because the sealing cement must be broken to remove a cord.

MOTOR ELECTRICAL CONNECTIONS

Single phase motors are for 230 volts only. A special control panel with start and run capacitors and start relay are required for these pumps.

These control panels must be obtained from Myers (or must be approved by Myers) or warranty on motor is void. Also, warranty is void if the heat sensor and seal fixture wires are not connected properly to control box terminal strip.

CAUTION: Pump motor is not to be taken apart in the field. Motors under warranty must be serviced by Myers authorized service facility or be sent to factory.

3WHV / V3WHV / 3WHR

IMPELLER AND VOLUTE PART NUMBERS

Pump	RPM	hp	Trim	Impeller	Volute
3WHV/V3WHV10M4-21	1750	1	5	22946C515	3WHV – 22945D000 V3WHV – 22945E100
3WHV/V3WHV10M4-03					
3WHV/V3WHV10M4-23					
3WHV/V3WHV10M4-43					
3WHV/V3WHV10M4-53					
3WHV/V3WHV15M4-21	1750	1.5	5.5	22946C511	
3WHV/V3WHV15M4-03					
3WHV/V3WHV15M4-23					
3WHV/V3WHV15M4-43					
3WHV/V3WHV15M4-53					
3WHV/V3WHV20M4-21	1750	2	6	22946C507	
3WHV/V3WHV20M4-03					
3WHV/V3WHV20M4-23					
3WHV/V3WHV20M4-43					
3WHV/V3WHV20M4-53					
3WHV/V3WHV30M4-21	1750	3	6.5	22946C503	
3WHV/V3WHV30M4-03					
3WHV/V3WHV30M4-23					
3WHV/V3WHV30M4-43					
3WHV/V3WHV30M4-53					
3WHV/V3WHV50M4-21	1750	5	6.75	22946C501	
3WHV/V3WHV50M4-03					
3WHV/V3WHV50M4-23					
3WHV/V3WHV50M4-43					
3WHV/V3WHV50M4-53					
3WHR15M4-21	1750	1.5	5	0708120002	27706D000
3WHR15M4-03					
3WHR15M4-23					
3WHR15M4-43					
3WHR15M4-53					
3WHR20M4-21	1750	2	5.25	070812012	
3WHR20M4-03					
3WHR20M4-23					
3WHR20M4-43					
3WHR20M4-53					
3WHR30M4-21	1750	3	6	070812022	
3WHR30M4-03					
3WHR30M4-23					
3WHR30M4-43					
3WHR30M4-53					
3WHR50M4-21	1750	5	6.75	070812032	
3WHR50M4-03					
3WHR50M4-23					
3WHR50M4-43					
3WHR50M4-53					

Pump Catalog No.	Shaft w/Rotor	Stator Only	Housing w/Stator
3WHV10M4-21	24416C000	24407C211	24406D120K
V3WHV10M4-21			
3WHV10M4-03	24416C001	24407C212	24406D125K
V3WHV10M4-03			
3WHV10M4-23	24416C001	24407C213	24406D130K
V3WHV10M4-23			
3WHV10M4-43	24416C001	24407C213	24406D135K
V3WHV10M4-43			
3WHV10M4-53	24416C001	24407C214	24406D140K
V3WHV10M4-53			
3WHV15M4-21	24416C000	24407C211	24406D120K
V3WHV15M4-21			
3WHV15M4-03	24416C001	24407C212	24406D125K
V3WHV15M4-03			
3WHV15M4-23	24416C001	24407C213	24406D130K
V3WHV15M4-23			
3WHV15M4-43	24416C001	24407C213	24406D135K
V3WHV15M4-43			
3WHV15M4-53	24416C001	24407C214	24406D140K
V3WHV15M4-53			
3WHV20M4-21	24416C002	24407C215	24406D145K
V3WHV20M4-21			
3WHV20M4-03	24416C003	24407C216	24406D150K
V3WHV20M4-03			
3WHV20M4-23	24416C003	24407C217	24406D155K
V3WHV20M4-23			
3WHV20M4-43	24416C003	24407C217	24406D160K
V3WHV20M4-43			
3WHV20M4-53	24416C003	24407C218	24406D165K
V3WHV20M4-53			
3WHV30M4-21	24416C004	24407C000	24406D170K
V3WHV30M4-21			
3WHV30M4-03	24416C004	24407C201	24406D175K
V3WHV30M4-03			
3WHV30M4-23	24416C004	24407C206	24406D180K
V3WHV30M4-23			
3WHV30M4-43	24416C004	24407C206	24406D185K
V3WHV30M4-43			
3WHV30M4-53	24416C004	24407C203	24406D190K
V3WHV30M4-53			
3WHV50M4-21	24416C004	24407C204	24406D170K
V3WHV50M4-21			
3WHV50M4-03	24416C004	24407C201	24406D175K
V3WHV50M4-03			
3WHV50M4-23	24416C004	24407C206	24406D180K
V3WHV50M4-23			
3WHV50M4-43	24416C004	24407C206	24406D185K
V3WHV50M4-43			
3WHV50M4-53	24416C004	24407C203	24406D190K
V3WHV50M4-53			

REGAL MOTOR END PARTS LIST

Item	Description	Qty.	Eng. No.
1	35° CORD ASSEMBLY 14-4	1	22569B421
	35° CORD ASSEMBLY 10-4	1	22569B402
	35° CORD ASSEMBLY 8-4 SOOW	1	22569B451
	35° CORD ASSEMBLY 8-4 W	1	22569B461
2	SCREW; MACH ST 10-24UNC x 3/8 LG	3	05434A043
3	WASHER; LOCK SHKPRF INTERNAL ST NO 10	1	06107A015
4	WASHER; SPRING FINGER 1.189 ID x 1.830 OD	2	19331A006
5	BEARING, BALL, UPPER	1	08565A022
6	HOUSING; MOTOR 3WHV SEWAGE PUMP CI	1	24406D001
7	STATOR	1	SEE CHART
8	SHAFT W/ ROTOR	1	SEE CHART

Item	Description	Qty.	Eng. No.
9	BEARING, BALL, LOWER	1	000650181
10	GASKET; RUBBER TETRASEAL 7 x 6-3/4 x 1/8	1	05014A181
11	SEAL, SHAFT 1-1/4	1	049160001
12	HOUSING; SEAL CI 3HP 3WHV SEWAGE PUMP	1	24414D000
13	SCREW; CAP SKT HD SST 7/16-14UNC-3A x 1-1/2 LG	4	06106A035
14	PLUG; PIPE MALL GALV 1/2 SQ HD	1	05022A039
15	BOLT, EYE; ELECTRO GALV 3/8-16THD x 1	1	21929A002
16	GASKET; RUBBER TETRASEAL 3-3/4 x 3-1/2 x 1/8	1	05014A133
17	SCREW; CAP HEX SST 7/16-14UNC x 2 LG	4	19102A022
18	GASKET; VELLUMOID 10-3/8 x 8-7/16 x 1/32	1	05231A079

3WHV / V3WHV / 3WHR

WET END DRAWINGS

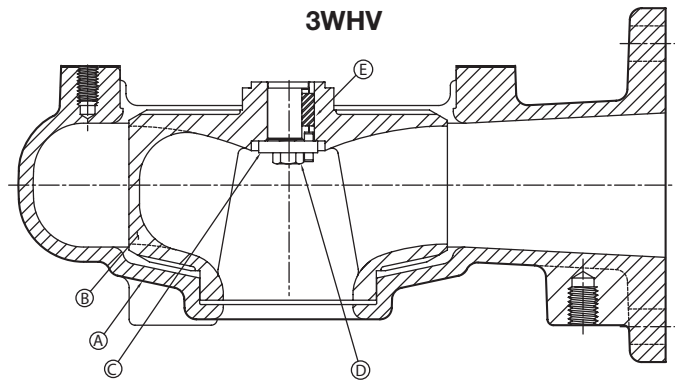
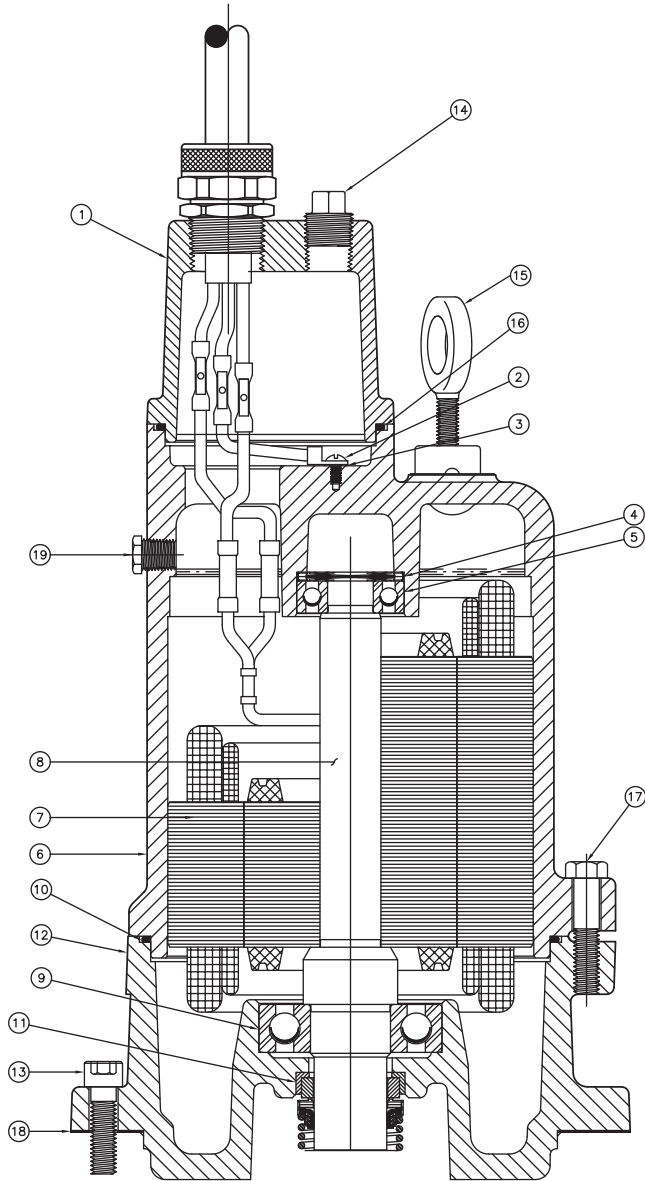

V3WHV VOLUTE

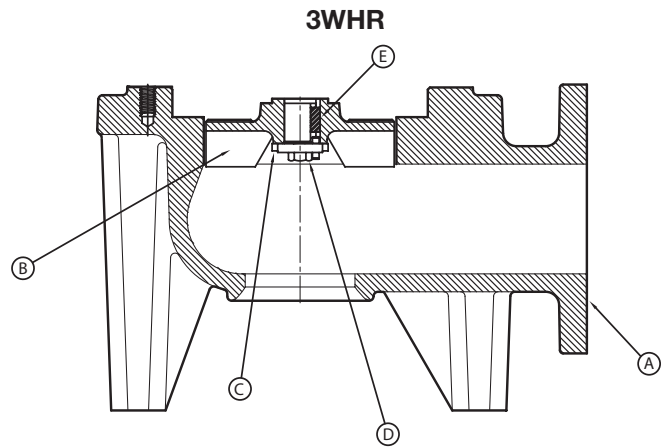
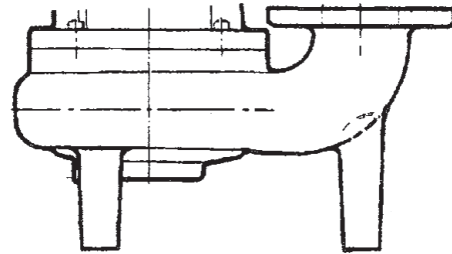

3WHV / V3WHV / 3WHR

Item	Description	Qty.	Eng. No.
A	VOLUTE	1	See Table
B	IMPELLER	1	See Table
C	WASHER; RETAINER, W/PIN, FOR 4R & 3WHV SERIES	1	23609A001
D	SCREW; CAP HEX SST 3/8-16 x 1 LG	1	19101A017
E	KEY; SQ SST 1/4 x 1/4 x 11/16	1	05818A074

4WHV / V4WHV / 4WHR

IMPELLER AND VOLUTE PART NUMBERS

Pump	RPM	hp	Trim	Impeller	Volute
4WHV/V4WHV30M4-21	1750	3	6	22711C518	4WHV – 22712D000 V4WHV – 22712E100
4WHV/V4WHV30M4-03					
4WHV/V4WHV30M4-23					
4WHV/V4WHV30M4-43					
4WHV/V4WHV30M4-53					
4WHV/V4WHV50M4-21	1750	5	7	22711C510	
4WHV/V4WHV50M4-03					
4WHV/V4WHV50M4-23					
4WHV/V4WHV50M4-43					
4WHV/V4WHV50M4-53					
4WHV/V4WHV75M4-03	1750	7.5	7.5	22711C506	
4WHV/V4WHV75M4-23					
4WHV/V4WHV75M4-43					
4WHV/V4WHV75M4-53					
4WHV/V4WHV100M4-03					
4WHV/V4WHV100M4-23					
4WHV/V4WHV100M4-43					
4WHV/V4WHV100M4-53					
4WHR30M4-21	1750	3	6	070814002	
4WHR30M4-03					
4WHR30M4-23					
4WHR30M4-43					
4WHR30M4-53					
4WHR50M4-21	1750	5	6.5	070814012	
4WHR50M4-03					
4WHR50M4-23					
4WHR50M4-43					
4WHR50M4-53					
4WHR75M4-03	1750	7.5	7.5	070814022	
4WHR75M4-23					
4WHR75M4-43					
4WHR75M4-53					

Pump Catalog No.	Shaft w/Rotor	Stator Only	Housing w/Stator
4WHV/4WHR30M4-21	24408C000	24407C200	24406D020K
V4WHV30M4-21			
4WHV/4WHR30M4-03	24408C000	24407C201	24406D025K
V4WHV30M4-03			
4WHV/4WHR30M4-23	24408C000	24407C202	24406D031K
V4WHV30M4-23			
4WHV/4WHR30M4-43	24408C000	24407C202	24406D035K
V4WHV30M4-43			
4WHV/4WHR30M4-53	24408C000	24407C203	24406D040K
V4WHV30M4-53			
4WHV/4WHR50M4-21	24408C000	24407C204	24406D045K
V4WHV50M4-21			
4WHV/4WHR50M4-03	24408C000	24407C205	24406D050K
V4WHV50M4-03			
4WHV/4WHR50M4-23	24408C000	24407C206	24406D055K
V4WHV50M4-23			
4WHV/4WHR50M4-43	24408C000	24407C206	24406D060K
V4WHV50M4-43			
4WHV/4WHR50M4-53	24408C000	24407C207	24406D065K
V4WHV50M4-53			
4WHV/4WHR75M4-03	24408C000	24407C208	24406D070K
V4WHV75M4-03			
4WHV/4WHR75M4-23	24408C000	24407C209	24406D075K
V4WHV75M4-23			
4WHV/4WHR75M4-43	24408C000	24407C209	24406D080K
V4WHV75M4-43			
4WHV/4WHR75M4-53	24408C000	24407C210	24406D085K
V4WHV75M4-53			
4WHV/4WHR100M4-03	24408C000	24407C208	24406D070K
V4WHV100M4-03			
4WHV/4WHR100M4-23	24408C000	24407C209	24406D075K
V4WHV100M4-23			
4WHV/4WHR100M4-43	24408C000	24407C209	24406D080K
V4WHV100M4-43			
4WHV/4WHR100M4-53	24408C000	24407C210	24406D085K
V4WHV100M4-53			

REGAL MOTOR END PARTS LIST

Item	Description	Qty.	Eng. No.
1	35' CORD ASSEMBLY 14-4	1	22569B431
	35' CORD ASSEMBLY 10-4	1	22569B406
	35' CORD ASSEMBLY 8-4 SOOW	1	22569B411
	35' CORD ASSEMBLY 8-4 W	1	22569B441
	SCREW; MACH ST 10-24UNC x 3/8 LG	6	05434A043
3	WASHER; LOCK SHKPRF INTERNAL ST NO 10	2	06107A015
4	WASHER; SPRING FINGER 1.189 ID x 1.830 OD	2	19331A006
5	BEARING, BALL, UPPER	1	08565A022
6	HOUSING; MOTOR 4WHV SEWAGE PUMP CI	1	24406D001
7	STATOR	1	SEE CHART
8	SHAFT W/ ROTOR	1	SEE CHART
9	BEARING, BALL, LOWER	1	08565A027
10	GASKET; RUBBER TETRASEAL 7 x 6-3/4 x 1/8	1	05014A181
11	SEAL, SHAFT 1-1/2	2	009200011
12	HOUSING; BEARING 4WHV SEWAGE PUMP CI	1	24411D000

Item	Description	Qty.	Eng. No.
13	SCREW; CAP HEX SST 7/16 x 1-1/2 LG	4	19102A006
14	RING; RET EXTERNAL SST 1-1/2 SHAFT	1	12558A018
15	BOLT, EYE; ELECTRO GALV 3/8-16THD x 1	1	21929A002
16	HOUSING; LOWER SEAL 4WHV SEWAGE PUMP CI	1	24412D000
17	SCREW; CAP HEX SST 7/16-14UNC x 2LG	4	19102A022
18	GASKET; VELLUMOID 10-3/8 x 8-7/16 x 1/32	1	05231A079
19	GROMMET; SEALING CONTROL 4WHV SERIES	1	24323A002
20	WIRE; ELECT 16 GA 1 STR YELLOW 20 LG	1	22500A126
21	FERRULE; RUBBER .312 OD .171 ID .265 LG ONE HOLE	1	12619A001
22	PLUG; SPECIAL 1/2 HEX BR ROD	1	21577A000
23	ELECTRODE; WIRE 4-1/2 LG	1	21792A003
24	SCREW; CAP SKT HD SST 3/8-16UNC-3A x 1 LG	4	06106A028
25	GASKET; RUBBER 7-1/2 x 7-1/4 x 1/8 THK	1	05014A176
26	GASKET; RUBBER TETRASEAL 3-3/4 x 3-1/2 x 1/8	1	05014A133

4WHV / V4WHV / 4WHR

WET END DRAWINGS

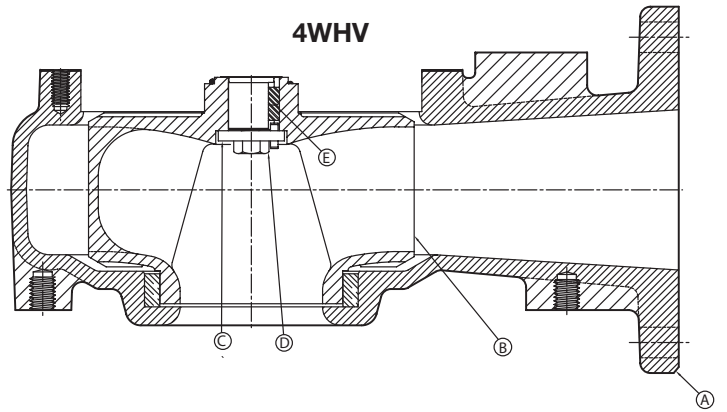
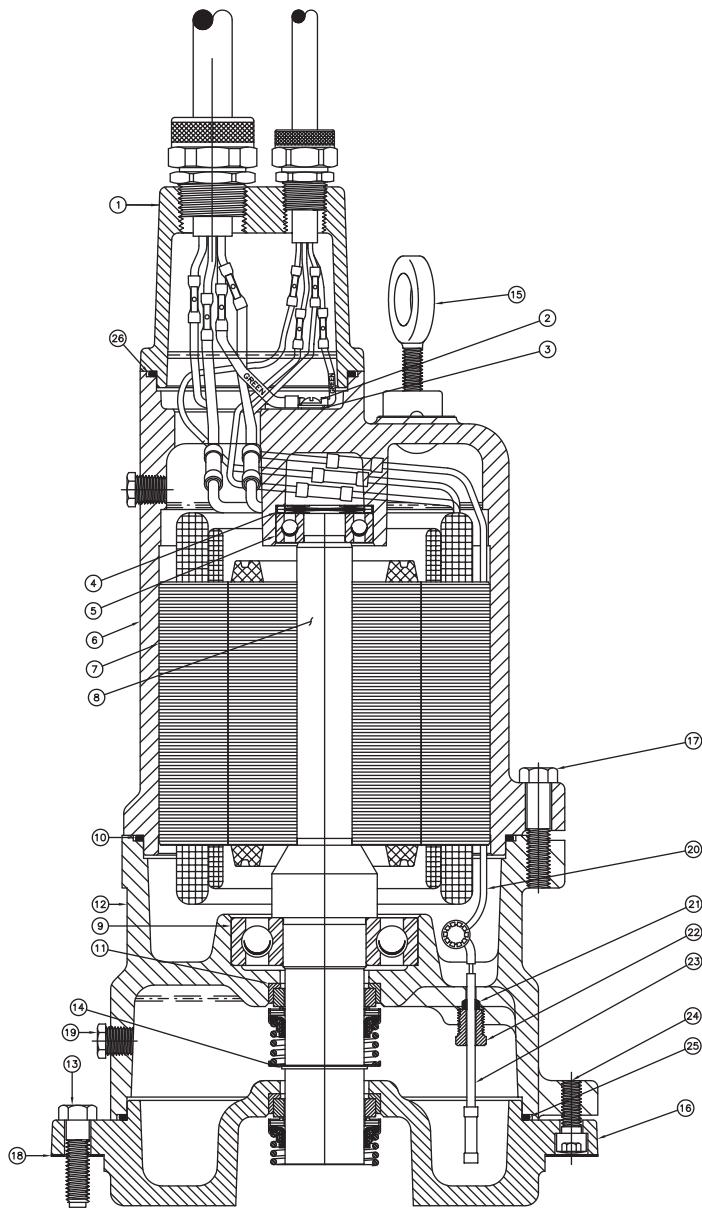

V4WHV VOLUTE

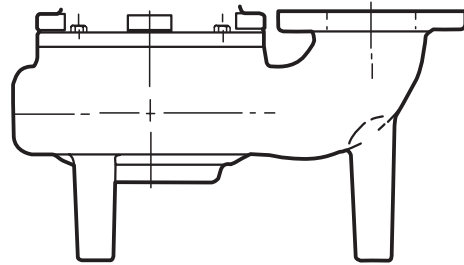

4WHR

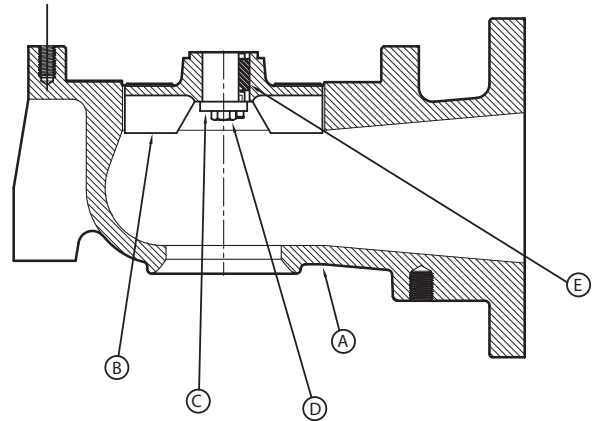

4WHV / V4WHV / 4WHR

Item	Description	Qty.	Eng. No.
A	VOLUTE	1	See Table
B	IMPELLER	1	See Table
C	WASHER; RETAINER, W/PIN, FOR 4V & 4WHV SERIES	1	23609A002
D	SCREW; CAP HEX SST 300 1/2-13UNC x 1-1/4 LG	1	19103A052
E	KEY; SQ SST 1/4 x 1/4 x 13/16	1	05818A066

3WHV / V3WHV / 3WHR WIRING DIAGRAMS

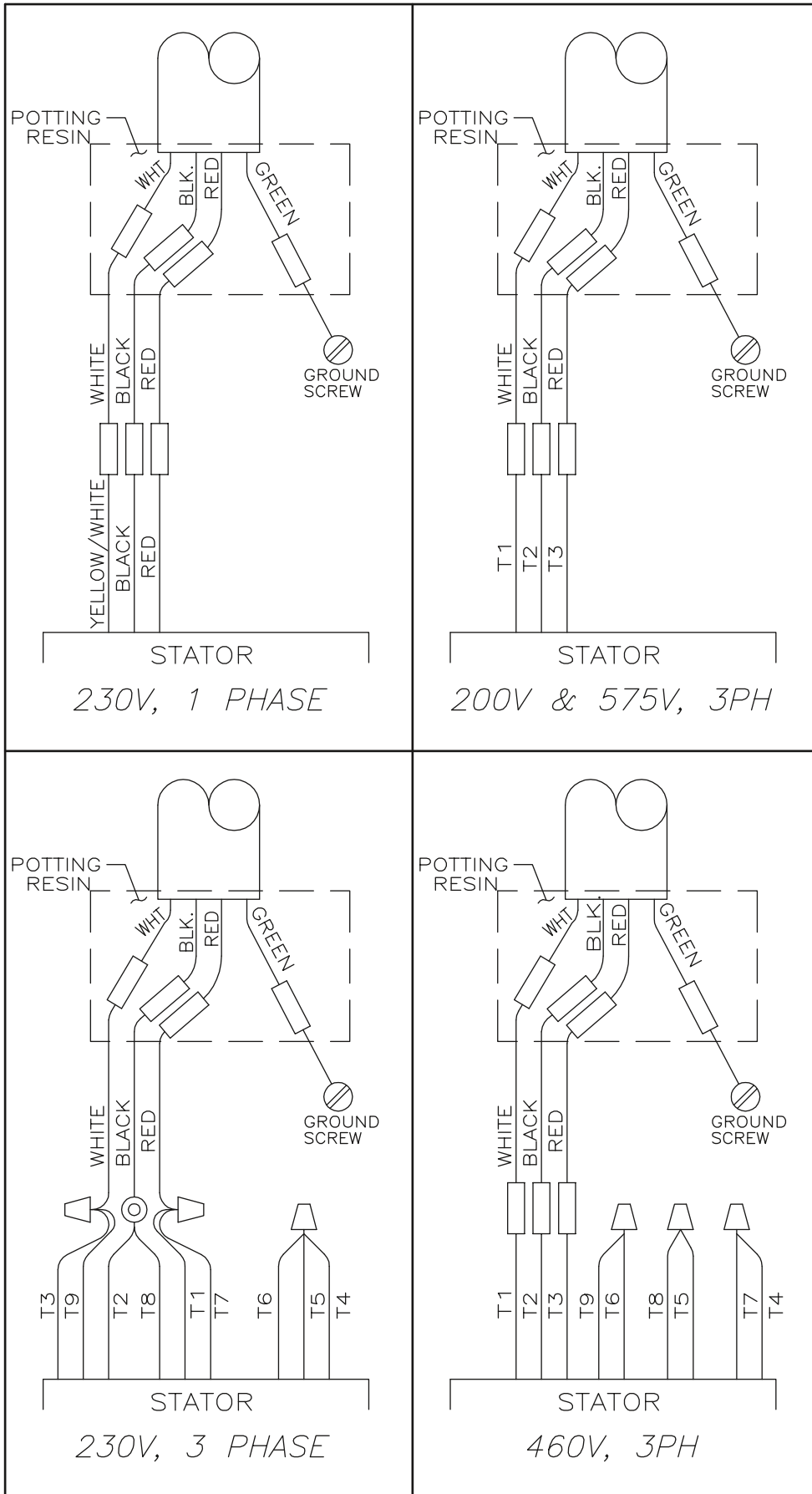

4WHV / V4WHV / 4WHR WIRING DIAGRAMS

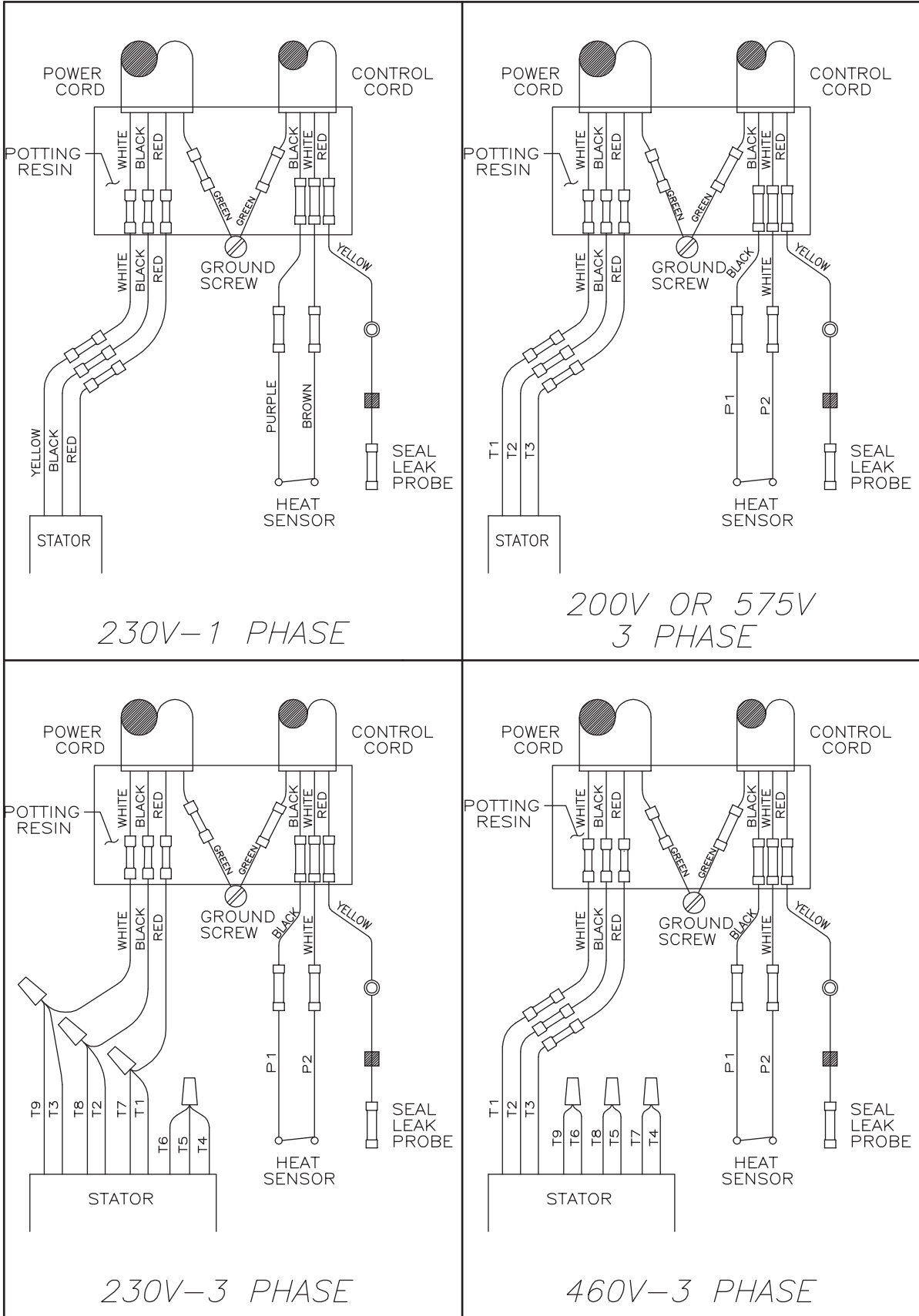

REMOVING PUMP CASE AND IMPELLER

In case of wear, damage due to dropping, plugged pump, or replacing a defective motor, the pump volute case and impeller can be removed in the field.

1. Remove bolts between seal housing flange and volute case. The motor and impeller can now be lifted off as a unit.
2. If necessary to remove impeller, lay pump on its side. With a screwdriver bend the tabs of the lockwasher away from the hex head bolt.
3. Loosen and remove the bolt by turning counter-clockwise. Since Loctite® is used to secure the bolt and is applied to the shaft/impeller interface, heating of the shaft end to 450° F will usually be required.
4. Impeller is mounted by a straight fit with driving key. Pry evenly on opposite impeller sides with two large screwdrivers or small bars behind the impeller.
5. Set motor on end with shaft up after removing impeller so that oil will not drain past the seal.

REPLACING IMPELLER AND PUMP CASE

1. Apply Loctite #680; before assembly, in keyway, in the impeller bore (lower shaft O.D.), and on the threads of the hex head cap screw.
2. Before placing the impeller on the shaft, be sure the mechanical seal and its spring are in place.
3. Position retaining washer with long pin extension in keyway.
4. Assemble hex head cap screw and tighten securely.

CAP SCREW	TORQUE VALUE
3/8-16	20 ft.-lbs.
1/2-13	43 ft.-lbs.
5/8-11	93 ft.-lbs.
3/4-10	128 ft.-lbs.

TROUBLE CHECK LIST

Troubles listed generally pertain to the pump and auxiliary components. Other trouble can occur from a faulty control box. These will be listed with the control box instructions.

CONDITION	PROBABLE CAUSE
Pump runs but does not pump liquid from basin.	<ol style="list-style-type: none">1. Pump impeller may be air locked; this occasionally occurs on a new installation. Start and stop pump several times to purge air. Be sure air vent hold in volute case is clean.2. Run additional water into basin so that pump will be submerged deeper to clear air.3. If pump is three phase, rotation may be wrong. See instructions for checking proper rotation.4. If pump has been installed for some time and does not pump, it may be clogged at inlet.5. Discharge gate valve may be closed.6. Discharge check valve may be clogged or have a broken clapper or spring.7. Discharge head may be too high. Check elevation.8. If above checks do not locate trouble, motor rotor may be loose on shaft which allows motor to run but will not turn impeller or only at low RPM.
Red light comes on at control box.	<ol style="list-style-type: none">1. This indicates some water has leaked past the lower seal and has entered the seal chamber and made contact with the electrode probe. Pump must be removed immediately from basin for replacement of lower seal. This preventive repair will save an expensive motor.

TROUBLE CHECK LIST (Cont'd)

CONDITION	PROBABLE CAUSE
Overload trips at control box and alarm buzzer or flashing red light comes on due to high water level in basin.	<ol style="list-style-type: none">1. Push red reset button to reset overload. If overload trips again after short run, pump has some damage and must be removed from basin for checking.2. Trouble may be from clogged impeller causing motor to overload or could be from failed motor.3. Trouble may be from faulty component in control box. Always check control box before removing pump.
Yellow run light stays on continuously.	<ol style="list-style-type: none">1. Indicates H-O-A switch may be in the Hand position.2. Level control switch may have failed causing pump to continue to operate when water is below lower control.3. Impeller may be partially clogged causing pump to operate at much reduced capacity.4. Gate valve or check valve may be clogged causing low pump flow.5. Pump may be air logged. Lift arm on check valve to vent off air. Also, check that the 5/32" vent hole in volute is open.
Circuit breaker trips.	<ol style="list-style-type: none">1. Reset breaker by pushing clear down on handle then back to On position. If breaker trips again in few seconds, it indicates excessive load probably caused by a short in the motor or control box. Check out instructions given with control box before pulling pump.2. If this condition happens after an electrical storm, motor or control box may be damaged by lightning.3. Resistance reading of the motor with lead wires disconnected from the control box can determine if trouble is in motor or control box.
Pump is noisy and pump rate is low.	<ol style="list-style-type: none">1. Impeller may be partially clogged with some foreign objects causing noise and overload on the motor.2. Impeller may be rubbing on wear ring due to bent shaft or misalignment.3. Pump may be operating too close to shut-off. Check head.
Grease and solids have accumulated around pump and will not pump out of basin.	<ol style="list-style-type: none">1. Lower control which may be set too high.2. Run pump on manual operation for several minutes with small amount of water running into basin to clean out solids and grease. This allows pump to break suction and surge, breaking up the solids. If level switch is set properly, this condition generally will not occur.3. Trash and grease may have accumulated around floats causing pump to operate erratically.

STANDARD LIMITED WARRANTY

Pentair Myers® warrants its products against defects in material and workmanship for a period of 12 months from the date of shipment from Pentair Myers or 18 months from the manufacturing date, whichever occurs first – provided that such products are used in compliance with the requirements of the Pentair Myers catalog and technical manuals for use in pumping raw sewage, municipal wastewater or similar, abrasive-free, noncorrosive liquids.

During the warranty period and subject to the conditions set forth, Pentair Myers, at its discretion, will repair or replace to the original user, the parts that prove defective in materials and workmanship. Pentair Myers reserves the right to change or improve its products or any portions thereof without being obligated to provide such a change or improvement for prior sold and/or shipped units.

Start-up reports and electrical schematics may be required to support warranty claims. Submit at the time of start-up through the Pentair Myers website: <http://forms.pentairliterature.com/startupform/startupform.asp?type=m>. Warranty is effective only if Pentair Myers authorized control panels are used. All seal fail and heat sensing devices must be hooked up, functional and monitored or this warranty will be void. Pentair Myers will cover only the lower seal and labor thereof for all dual seal pumps. Under no circumstance will Pentair Myers be responsible for the cost of field labor, travel expenses, rented equipment, removal/reinstallation costs or freight expenses to and from the factory or an authorized Pentair Myers service facility.

This limited warranty will not apply: (a) to defects or malfunctions resulting from failure to properly install, operate or maintain the unit in accordance with the printed instructions provided; (b) to failures resulting from abuse, accident or negligence; (c) to normal maintenance services and parts used in connection with such service; (d) to units that are not installed in accordance with applicable local codes, ordinances and good trade practices; (e) if the unit is moved from its original installation location; (f) if unit is used for purposes other than for what it is designed and manufactured; (g) to any unit that has been repaired or altered by anyone other than Pentair Myers or an authorized Pentair Myers service provider; (h) to any unit that has been repaired using non factory specified/OEM parts.

Warranty Exclusions: PENTAIR MYERS MAKES NO EXPRESS OR IMPLIED WARRANTIES THAT EXTEND BEYOND THE DESCRIPTION ON THE FACE HEREOF. PENTAIR MYERS SPECIFICALLY DISCLAIMS THE IMPLIED WARRANTIES OF MERCHANTABILITY AND FITNESS FOR ANY PARTICULAR PURPOSE.

Liability Limitation: IN NO EVENT SHALL PENTAIR MYERS BE LIABLE OR RESPONSIBLE FOR CONSEQUENTIAL, INCIDENTAL OR SPECIAL DAMAGES RESULTING FROM OR RELATED IN ANY MANNER TO ANY PENTAIR MYERS PRODUCT OR PARTS THEREOF. PERSONAL INJURY AND/OR PROPERTY DAMAGE MAY RESULT FROM IMPROPER INSTALLATION. PENTAIR MYERS DISCLAIMS ALL LIABILITY, INCLUDING LIABILITY UNDER THIS WARRANTY, FOR IMPROPER INSTALLATION. PENTAIR MYERS RECOMMENDS INSTALLATION BY PROFESSIONALS.

Some states do not permit some or all of the above warranty limitations or the exclusion or limitation of incidental or consequential damages and therefore such limitations may not apply to you. No warranties or representations at any time made by any representatives of Pentair Myers shall vary or expand the provision hereof.



MYERS®

1101 MYERS PARKWAY
ASHLAND, OHIO, USA 44805
419-289-1144

490 PINEBUSH ROAD, UNIT #4
CAMBRIDGE, ONTARIO, CANADA N1T 0A5
800-363-PUMP

WWW.FEMYERS.COM