

Drive Replacement Kit (P/N 358085 and 358086) Installation Guide

For WhisperFloXF® VS and Max-E-ProXF® VS Commercial Variable Speed Pumps

Removing and Replacing the Drive Assembly

Removing the Existing Drive Assembly:

1. If possible, record your programmed schedule and priming speed before proceeding.
2. Disconnect power to the pump at the circuit breaker. **Wait five (5) minutes after disconnecting the power before removing the drive cover.**
3. Using a #2 Phillips-head screwdriver, uninstall the field wiring compartment cover from the side of the drive. Place the cover and all screws aside.
4. Uninstall field wiring, strain relief and/or conduit from the drive.
5. Using a T20 star-head screwdriver, remove the four (4) Drive Cover Screws (**Figure 1**).
6. Gently lift the drive cover and disconnect the keypad cable from the Keypad Terminal (**Figure 2**). Place the drive cover aside.
7. Carefully disconnect the four (4) white Motor Connections (**Figure 2**) from their flag terminals.
Note: Take note of which flag terminal each cable is paired with. Each connector must be installed to the same flag terminal when installing the new drive.
8. Using a T20 star-head screwdriver, remove the two (2) Front Drive-to-Motor Screws (**Figure 2**).
9. Using a T20 star-head screwdriver, remove the two (2) Rear Drive-to-Motor Screws (**Figure 3**) from underneath the drive.
10. Lift the drive away from the motor, carefully guiding the motor cables through the opening in the front of the drive. Place the old drive aside.

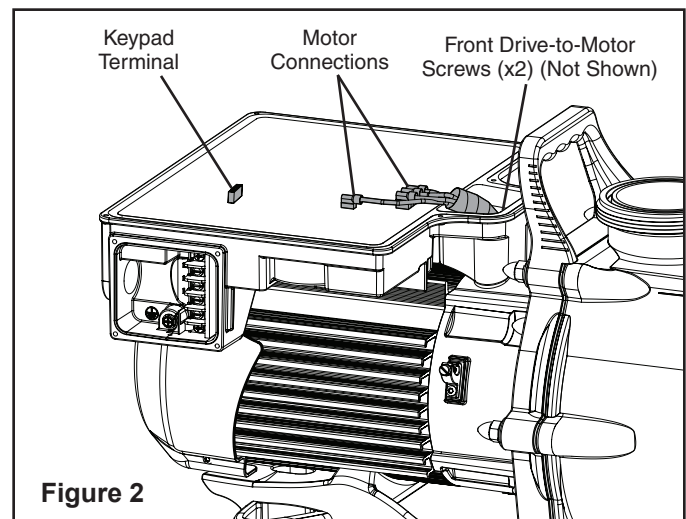
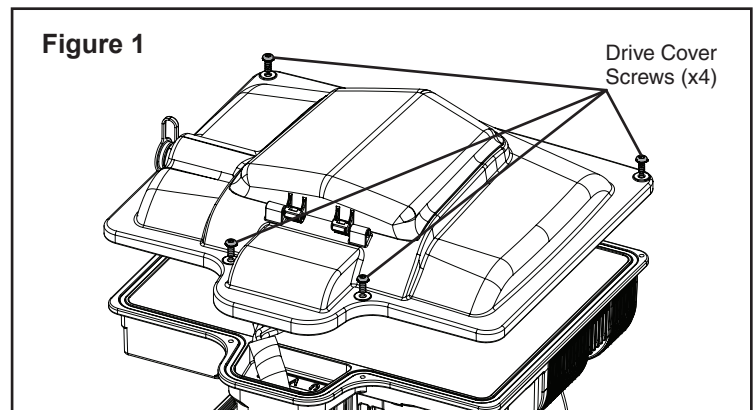

Installing the New Drive Assembly:

11. Place the new drive onto the motor, carefully feeding the Motor Connectors through the opening in the front of the drive.
12. Reinstall the four (4) Drive-to-Motor Screws (**Figures 2 and 3**).
13. Referring back to the notes taken in Step 7, plug each motor cable into its corresponding flag terminal.
14. Reconnect the drive cover's keypad connector to the drive and seat the drive cover onto the drive body.
15. Reinstall the four (4) Drive Cover Screws (**Figure 1**).
16. Reconnect the Main Power supply and strain relief or conduit for the electrical wires.
17. Reinstall the field wiring compartment cover using the four (4) cover screws.
18. Return power to the pump at the circuit breaker.
19. Your pump's time, schedule and priming speed will need to be reprogrammed. Refer to the pump "Installation and User's Guide" for programming procedures.

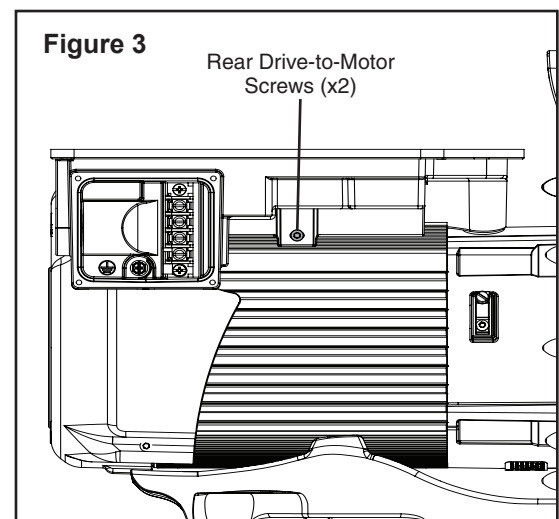

Drive Cover Replacement Kit (P/N 358093 and 358094) Installation Guide

For WhisperFloXF® VS and Max-E-ProXF® VS Commercial Variable Speed Pumps

Removing and Replacing the Drive Cover

1. If possible, record your programmed schedule and priming speed before proceeding.
2. Disconnect power to the pump at the circuit breaker. **Wait five (5) minutes after disconnecting the power before removing the drive cover.**
3. Using a T20 star-head screwdriver, remove the four (4) Drive Cover Screws (**Figure 4**).
4. Gently lift the drive cover and disconnect the keypad cable from the Keypad Terminal (**Figure 5**). Place the drive cover aside.
5. Ensure the Drive Gasket (**Figure 5**) is correctly seated into the groove around the outer edge of the drive body.
6. Plug the new drive cover's keypad cable into the Keypad Terminal (**Figure 5**) and seat the new drive cover onto the drive body.
7. Reinstall the four (4) Drive Cover Screws (**Figure 4**).
8. Return power to the pump at the circuit breaker.
9. The schedule, priming speed, and time will need to be reprogrammed. Refer to the pump "Installation and User's Guide" for programming procedures.

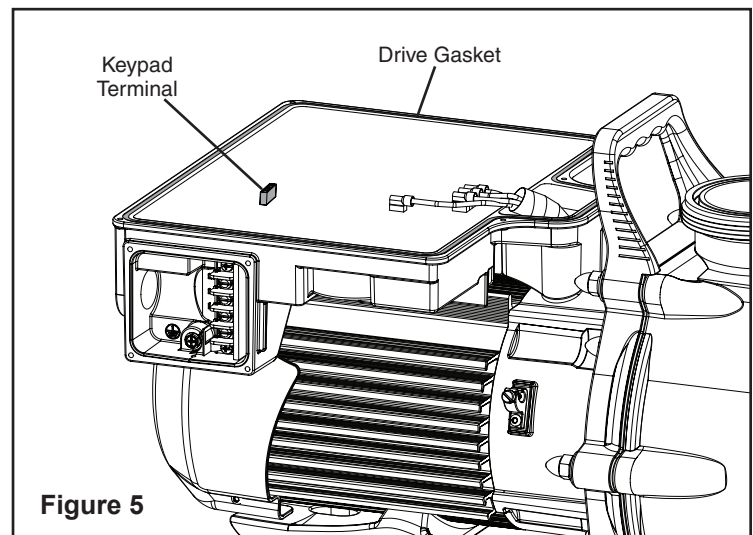
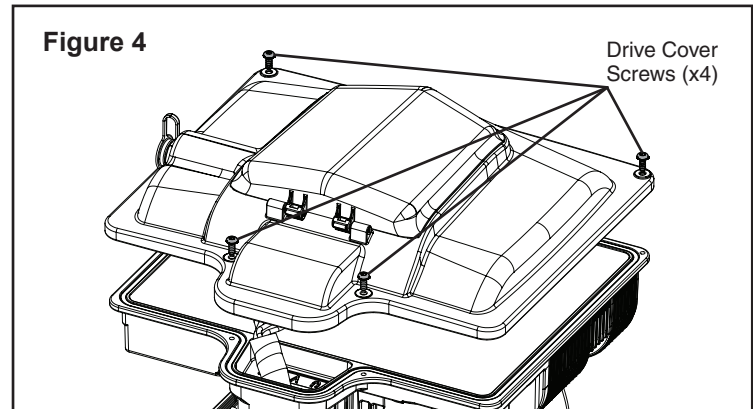

1620 HAWKINS AVE., SANFORD, NC 27330 • (919) 566-8000
10951 WEST LOS ANGELES AVE., MOORPARK, CA 93021 • (805) 553-5000
WWW.PENTAIR.COM

All Pentair trademarks and logos are owned by Pentair or one of its global affiliates. WhisperFloXF® VS and Max-E-ProXF® VS are registered trademarks of Pentair Water Pool and Spa, Inc. and/or its affiliated companies in the United States and/or other countries. Unless expressly noted, names and brands of third parties that may be used in this document are not used to indicate an affiliation or endorsement between the owners of these names and brands and Pentair Water Pool and Spa, Inc. Those names and brands may be the trademarks or registered trademarks of those third parties. Because we are continuously improving our products and services, Pentair reserves the right to change specifications without prior notice. Pentair is an equal opportunity employer.

© 2019 Pentair Water Pool and Spa, Inc. All rights reserved. This document is subject to change without notice.



P/N 358078 REV. A 5/2/19