

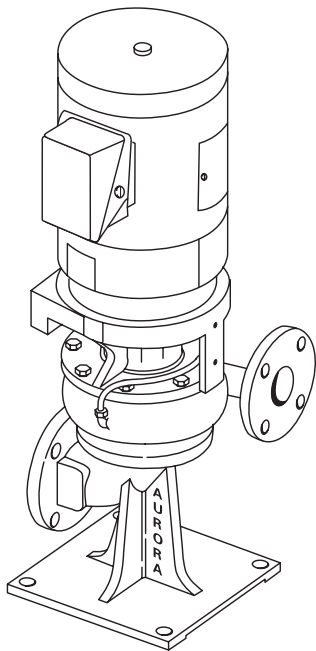

**AURORA<sup>®</sup>**

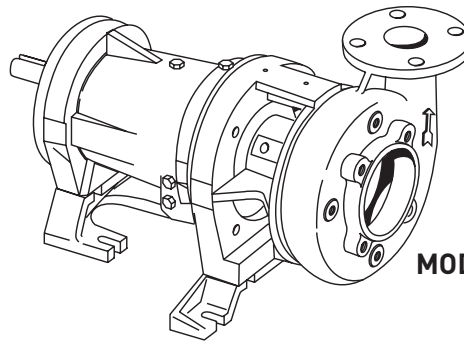

**MODEL 342A**



**MODEL 344A**

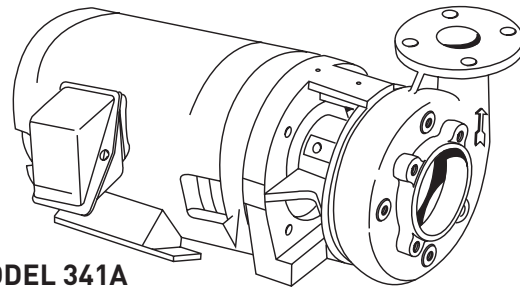

**MODEL 341A**

# MODELS 341A, 342A and 344A **SINGLE STAGE END SUCTION PUMPS**

## **INSTRUCTION AND REPAIR MANUAL**

NOTE! To the installer: Please make sure you provide this manual to the owner of the equipment or to the responsible party who maintains the system.

NOTE

This repair manual is applicable to pump Models 341A, 342A and 344A. All photos illustrate Model 344A.

**ATTENTION: SAFETY WARNINGS:**

Read and understand all warnings before installation or servicing pump.

**CALIFORNIA PROPOSITION 65 WARNING:**

 **Warning:** This product and related accessories contain chemicals known to the State of California to cause cancer, birth defects or other reproductive harm.

**OPERATIONAL LIMITS: \***

Maximum Operating Pressure: 175 psi at Temperatures to 150°F (65.6°C)  
Maximum Operating Temperature: 225°F (107°C)

\* See ASTM A126/ANSI B16.1 for pressure/temperature ratings of flanges.

**ELECTRICAL SAFETY:**

 **Warning:** Electrical Shock Hazard

All electrical connections are to be made by a qualified electrician in accordance with all codes and ordinances. Failure to follow these instructions could result in serious personal injury, death or property damage.

 **Warning:** Electrical Overload Hazard

Insure all motors have properly sized overload protection. Failure to follow these instructions could result in serious personal injury, death or property damage.

 **Warning:** Sudden Start-Up Hazard

Disconnect and lockout power source before servicing. Failure to follow these instructions could result in serious personal injury, death or property damage.

**HIGH TEMPERATURE SAFETY:**

 **Warning:** Hot Surface Hazard

If pumping hot water, insure guards or proper insulation is installed to protect against skin contact to hot piping or pump components. Failure to follow these instructions could result in serious personal injury, death or property damage.

 **Warning:** Spraying Water Hazard

When servicing pump replace all gaskets and seals. Do not re-use old gaskets or seals. Failure to follow these instructions could result in serious personal injury, death or property damage.

**HIGH PRESSURE SAFETY:**

 **Warning:** High Pressure Hazard

The pump is rated at a maximum of 175 psi at 150°F. Do not exceed this pressure. Install properly sized pressure relief valves in system. Failure to follow these instructions could result in serious personal injury, death or property damage.

 **Warning:** Expansion Hazard

Water expands when heated. Install properly sized thermal expansion tanks and relief valves. Failure to follow these instructions could result in serious personal injury, death or property damage.

**SERVICE**

Your Aurora pump requires no maintenance other than periodic inspection, occasional cleaning and lubrication of bearings (MODEL 344A only). The intent of inspection is to prevent breakdown, thus obtaining optimum service life. The liquid end of the pump is lubricated by the fluid being pumped and therefore does not require periodic lubrication. The motor, however may require lubrication, in which case, the motor manufacturer's recommendation should be followed.

**LUBRICATION OF IMPELLER SHAFT BEARINGS**

The MODEL 344A pump is available with three options for lubricating the shaft bearings. They are:

1. Regreasable (standard)
2. Oil Lubrication
3. Sealed Bearings, Permanent Lubrication

Regreasable bearings will require periodic lubrication and can be accomplished by using the zerk or lubrication fittings in the cartridge cap and power frame. Lubricate the bearings at regular intervals using a grease of high quality. Polyurea base grease is recommended as lubricants for pumps operating in both wet and dry locations. Mixing of different brands of grease should be avoided due to possible chemical reactions between the brands which could damage the bearings. Accordingly, avoid grease of vegetable or animal base which can develop acids, as well as grease containing rosin, graphite, talc and other impurities. Under no circumstances should used grease be reused.

Over lubrication should be avoided as it may result in overheating and possible bearing failure. Under normal application, adequate lubrication is assured if the amount of grease is maintained at 1/3 to 1/2 the capacity of the bearing and adjacent space surrounding it.

In dry locations, each bearing will need lubrication at least every 600 hours of running time or every 6 to 12 months, whichever is more frequent. In wet locations the bearings should be lubricated at least after every 300 hours of running time or every 4 to 6 months, whichever is more frequent. A unit is considered to be installed in a wet location if the pump and motor are exposed to dripping water, to the weather, or to heavy condensation such as is found in unheated and poorly ventilated underground locations.

Oil lubricated bearings are optional on MODEL 344 pumps. A fixed oil level is maintained with the power frame by an oiler which allows visual indications of reserve oil.

At initial installation and before starting a unit that has been shut down for repairs or for any extended length of time, run enough 10W-30 weight motor oil through the oiler to maintain a constant oil level to insure that the bearing will never be without an oil supply. Oil will have to be added at intervals to maintain a constant level in the oiler. This interval can only be determined by experience.

Under working conditions, oil will breakdown and need to be replaced at regular intervals. The length of these intervals will depend on many factors. Under normal operation, in clean and dry locations, the oil should be changed about once a year. However, when the pump is exposed to dirt contamination, high temperatures (200°F. or above) or a wet location, the oil may have to be changed every 2 to 3 months.

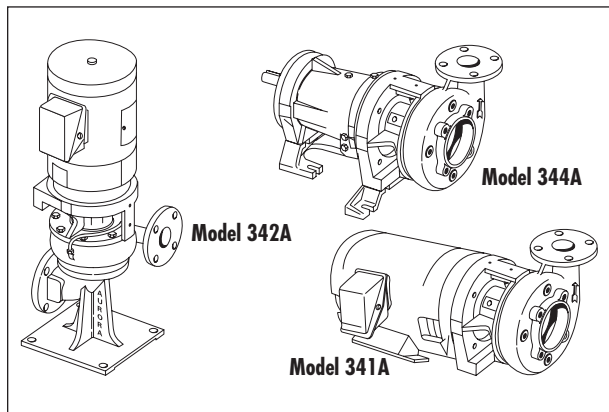

A. Assembled Units.

## CAUTION

Use normal fire caution procedures when using any petroleum cleaner.

### REPAIRS

Before starting any work, insure the electrical power is locked out, the system pressure has been lowered to 0 psi and temperature of the unit is at a safe level.

The pump may be disassembled using the illustrations and text provided. Although complete disassembly is covered, it will seldom be necessary to completely disassemble your Aurora pump.

The illustrations accompanying the disassembly instructions show the pump at various stages of disassembly. The illustrations are intended to aid in the correct identification of the parts mentioned in the text.

Inspect removed parts at disassembly to determine if they can be reused. Ball bearings that turn roughly or show wear should be replaced. Cracked castings should never be reused. Scored or worn pump shafts should be replaced. Gaskets should be replaced at reassembly simply as a matter of economy. They are much less expensive to replace routinely than to replace singly as the need arises.

#### **Warning:** Sudden Start-Up Hazard

Disconnect and lockout power source before servicing. Failure to follow these instructions could result in serious personal injury, death or property damage.

#### **Warning:** Hot Surface Hazard

If pumping hot water, insure guards or proper insulation is installed to protect against skin contact to hot piping or pump components. Failure to follow these instructions could result in serious personal injury, death or property damage.

#### **Warning:** High Pressure Hazard

The pump is rated at a maximum of 175 psi at 150°F. Do not exceed this pressure. Install properly sized pressure relief valves in system. Failure to follow these instructions could result in serious personal injury, death or property damage.

#### **Warning:** Spraying Water Hazard

When servicing pump replace all gaskets and seals. Do not re-use old gaskets or seals. Failure to follow these instructions could result in serious personal injury, death or property damage.

## MODELS 341A-342A-344A

### DISASSEMBLY

Disassemble only what is needed to make repairs or accomplish inspection. (See Figure 2 for Model 341A, Figure 3 for Model 342A and Figure 3 for Model 344A.)

1. Disconnect and lockout power source to prevent drive unit from being energized during disassembly.
2. Unscrew the two drain plugs (4) from the casing (6). On Model 342A pumps, remove plugs (74 and 75) to drain pump. Also unscrew the two plugs (4) from casing (6).
3. Remove all relief, cooling, flushing or drain lines from pump, including compression connections (1 and 2) and tubing (3). Break suction and discharge connections unless it is intended to remove the power frame or motor assembly and leave casing (6) in the line. On Model 342A pumps, break discharge connections only, unless it is desired to remove base (73). Remove capscrews (39) and lift pump assembly from base (73). Remove gasket (72).
4. On Model 344A pumps, remove the flexible coupling from between the pump and motor. Next unscrew the bolts that hold support(s) (41 and 64) to the base and slide the pump out to be worked on.
5. Remove capscrews (5) and pull casing (6) from bracket (35). Remove gasket (8).
6. Unscrew impeller screw (9) and remove washer (9A), taking care not to damage gasket (9B) or capscrew seal (9C).

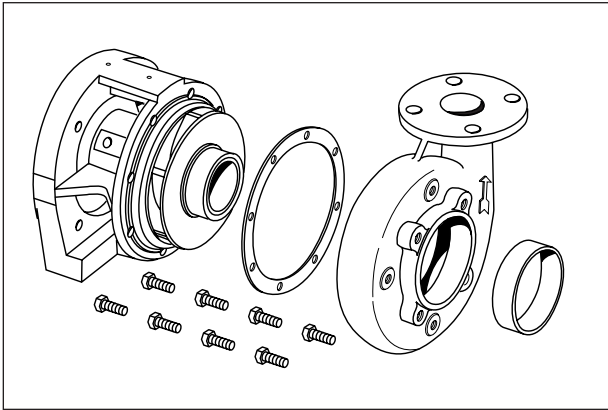

B. Casing, Gasket, and Wearing Ring Removed.

7. Slide impeller (11) and impeller key (12) from the shaft, again taking care not to damage gasket (10) located behind impeller. Remove gasket (10).
8. Wearing ring(s) (7 and 16) are pressed into their housings with an interface fit and must be removed with a puller. New ring(s) should be used for reassembly since it is likely that during removal this fit will be lost. Do not remove wearing rings if not being replaced.

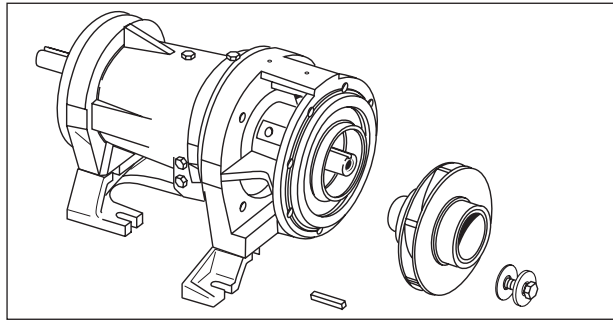

C. Impeller and Key Removed.

9. Impeller wearing rings (optional - 14 and 15) are pressed on and must be cut off if replacement is necessary. If they are turned off in a lathe, take care not to cut into the impeller.
10. Slide sleeve (25) with rotating parts of mechanical seal (27) from the shaft. The sleeve should be carefully cleaned to remove any residue that may be remaining in the seal area. The rubber in seal (27) may have become partially adhered to the sleeve. The sleeve must also be checked for abrasion or corrosion that can occur when fluid residue penetrates between the seal (27) and sleeve (25). The sleeve under the seal may be polished lightly to a 32 RMS finish before reassembly. Do not reuse a pitted sleeve. Pin (61) may be removed if necessary.

### CAUTION

The mechanical seal (see Figure 1) is a precision product and must be treated as such. During removal, great care must be taken to avoid dropping any part of the seal. Take particular care not to scratch the lapped faces on the washer or the sealing seat. If any wear of the seal faces is noted, it is recommended to replace with a new seal during reassembly.

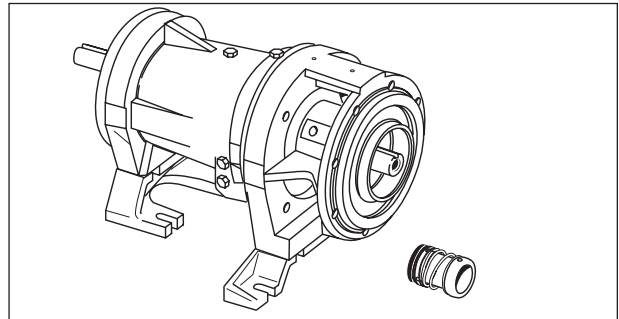

D. Mechanical Seal Removed.

11. On Model 344A pumps, remove capscrews (39 and 62) and washers (40 and 63) to take off support feet (41 and 64). On Model 341A frame size 143 thru 184-JM only, unscrew capscrews (39) washers (40) and remove support (41) from bracket (35).
12. Unscrew capscrews (32) to remove bracket (35) from frame (57) or motor on Models 341A and 342A.

## MODELS 341A-342A-344A

13. The seal flexible cup and stationary seat should be pressed out of the bracket (35) and the cavity cleaned of all residue. Make sure that the 1/32 inch radius in the seal seat cavity is not damaged during disassembly since a sharp edge can easily cut the flexible cup during reassembly.

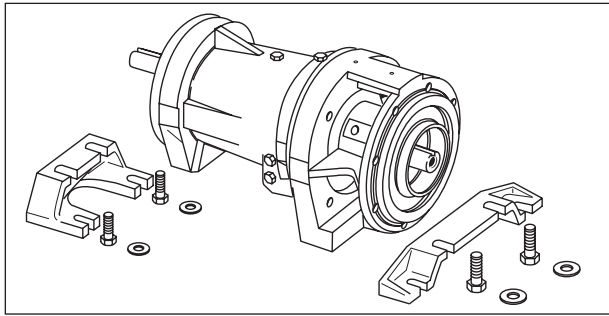

E. Support Feet Removed.

14. On Model 344A pumps, remove key (42) from the shaft and remove slingers (47 and 47A).
15. Unscrew capscrews (48) and remove bearing cap (49). Remove "O" ring (oil lubed only) (50) and retainer ring (52).

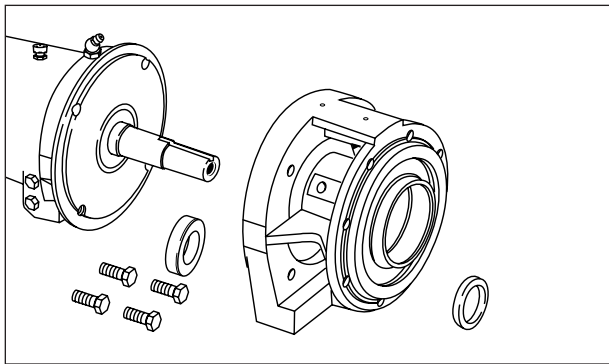

F. Bracket and Slinger Seal Flexible Cup and Stationary Seat Removed.

16. Slide out shaft (55) and bearings (53 and 54). Since bearings (53 and 54) are press fitted on the shaft, they will have to be pulled or pressed off the shaft. Remove grease seals (51) from frame (57), and bearing cap (49).
17. Remove nameplate (34) and screws (33) only if replacement is needed.

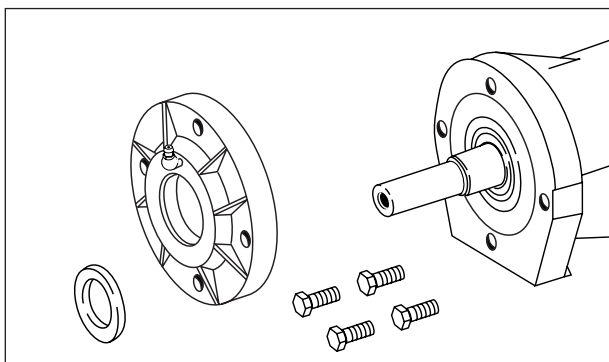

G. Bearing Cap and Slinger Removed.

## REASSEMBLY

Reassembly will generally be in reverse order of disassembly. If disassembly was not complete, use only those steps related to your particular repair program.

1. Press grease seals (51) into frame (57). (344A)
2. Press bearings (53 and 54) onto shaft (55). Snap retainer ring (52) into place. (344A)

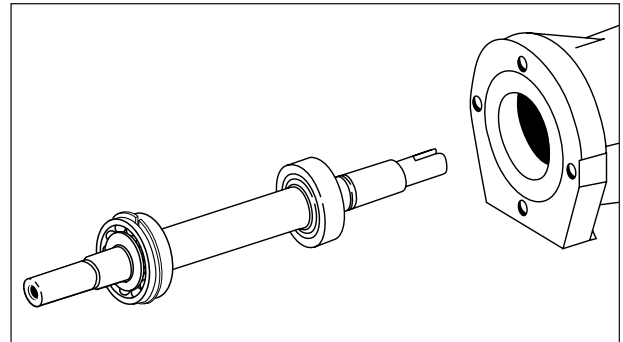

H. Shaft Assembly Removed.

3. Slide shaft (55) and bearings (53 and 54) into frame (57) until retainer ring on bearing (54) comes in contact with frame (57). Place "O" ring (oil lubed only) (50) in place. (344A)
4. Fasten bearing cap (49) in position with capscrews (48). Insert grease seals (51A) and position slingers (47 and 47A) on the shaft. (344A)
5. The mechanical seal (27) (see Figure 1) cannot be installed as an assembly. It is necessary to have the seal seat properly in place in bracket (35) before the balance of parts can be added.

Thoroughly inspect the seal cavity in seal bracket, checking for burrs or nicks which could damage flexible cup of mechanical seal. Apply a film of liquid dishwashing detergent (do not use oil or grease) to the flexible cup and seal seat. Insert seat in cup and install in seal bracket, taking care to seat it evenly and squarely.

### NOTE

If it is not possible to insert seat with fingers, place the cardboard protecting ring furnished with seal over lapped face of seat and press into place with a piece of tubing having end cut square. Tubing should be slightly larger than the diameter of the shaft. Remove cardboard after seat is firmly seated.

6. On Model 344A pumps, mount bracket (35) by screwing capscrews (32) evenly into frame (57) to assure proper alignment. Turn all capscrews in an even amount. Fasten the bracket and frame to supports (41 and 64) by placing washers (40 and 63) over capscrews (39 and 62) and screwing them into position.

On Model 341A and 342A pumps position bracket (35) on the motor and secure with capscrews (32). Tighten screws evenly to assure proper alignment.



## MODELS 341A-342A-344A

- Secure support (41) to bracket (35) with capscrews (39) and washers (40). Frame sizes 143 thru 184-JM Model 341A only.
- If nameplate (34) was removed, install and attach with screws (33).
  - Wipe the sealing faces of the seat and seal washer clean. Replace pin (61) in sleeve if it was removed during disassembly. Apply a film of liquid dishwashing detergent to the washer and bellows of the seal and slide the remaining seal parts onto the sleeve making sure the washer is seated against the seal seat. Check the proper sequence of assembly as indicated in Figure 1. The shaft sleeve with the seal rotating assembly on it may now be replaced onto the motor shaft. Spring tension will probably prevent the sleeve from remaining in position axially until the impeller is locked against it.
  - Press wearing ring(s) (7 and 16) in casing (6) and bracket (35). Rings should not be hammered into place. Use a press, or clamp the parts in a bench vise, using wooden blocks to protect the rings. It may be necessary to pin or dowel the rings after assembly if the insert or casing has had rings replaced before, since each reassembly can stretch or tear metal and thereby loosen the fits. If the facilities are available, it is good practice to take a very light finish cut or to ream the inside diameter of the casing rings after pressing to restore roundness. When rings are pressed, they may get squeezed out of shape.
  - Coat the mating surfaces of impeller wear ring(s) (optional - 14 and 15) and impeller (11) with Loctite sealant grade 271. Replace wear rings, using the same care as for the case wear ring(s). If the rings are to be trued on a lathe, do not clamp the impeller so tightly that it is permanently distorted.
  - Carefully replace gasket (10) on motor end of impeller. Assembly key (12) and impeller (11) to motor shaft. Secure impeller with gasket (9B), washer (9A), capscrew seal (9C) and impeller screw (9).
  - Install the two pipe plugs (4) in the pump casing. Position the gasket (8) and casing (6) against the motor bracket and secure with screws (5). On Model 342A pumps position gasket (72) and set pump assembly in place. Tighten pump to base (73) with capscrews (39).
  - Replace all relief, cooling, flushings, or drain lines from the pump including compression connections (1 and 2) and tubing (3). Replace all grease fittings pipe plugs, tube vents and oiler assembly for oil lubricated units. Connect discharge piping and suction piping, if required. Make sure to install gaskets on the flanged connections. On Model 342A pumps replace plugs (74 and 75) in base elbow (73).
  - Read carefully the section of the manual titled INSTALLATION, especially those paragraphs referring to pump and coupling alignment.
  - Connect electricity to the motor.

## STARTING PUMP AFTER REASSEMBLY

Do not start pump until all air and vapor has been bled and until making sure that there is liquid in the pump to provide the necessary lubrication. Without the fluid around it, the seal may be ruined in a few seconds of operation. It is possible that the mechanical seal may drip during the first few minutes to one hour of operation.



### **Warning:** Hot Surface Hazard

If pumping hot water, insure guards or proper insulation is installed to protect against skin contact to hot piping or pump components. Failure to follow these instructions could result in serious personal injury, death or property damage.



### **Warning:** Spraying Water Hazard

When servicing pump replace all gaskets and seals. Do not re-use old gaskets or seals. Failure to follow these instructions could result in serious personal injury, death or property damage.



### **Warning:** Electrical Shock Hazard

All electrical connections are to be made by a qualified electrician in accordance with all codes and ordinances. Failure to follow these instructions could result in serious personal injury, death or property damage.



### **Warning:** Electrical Overload Hazard

Insure all motors have properly sized overload protection. Failure to follow these instructions could result in serious personal injury, death or property damage.



### **Warning:** Sudden Start-Up Hazard

Disconnect and lockout power source before servicing. Failure to follow these instructions could result in serious personal injury, death or property damage.

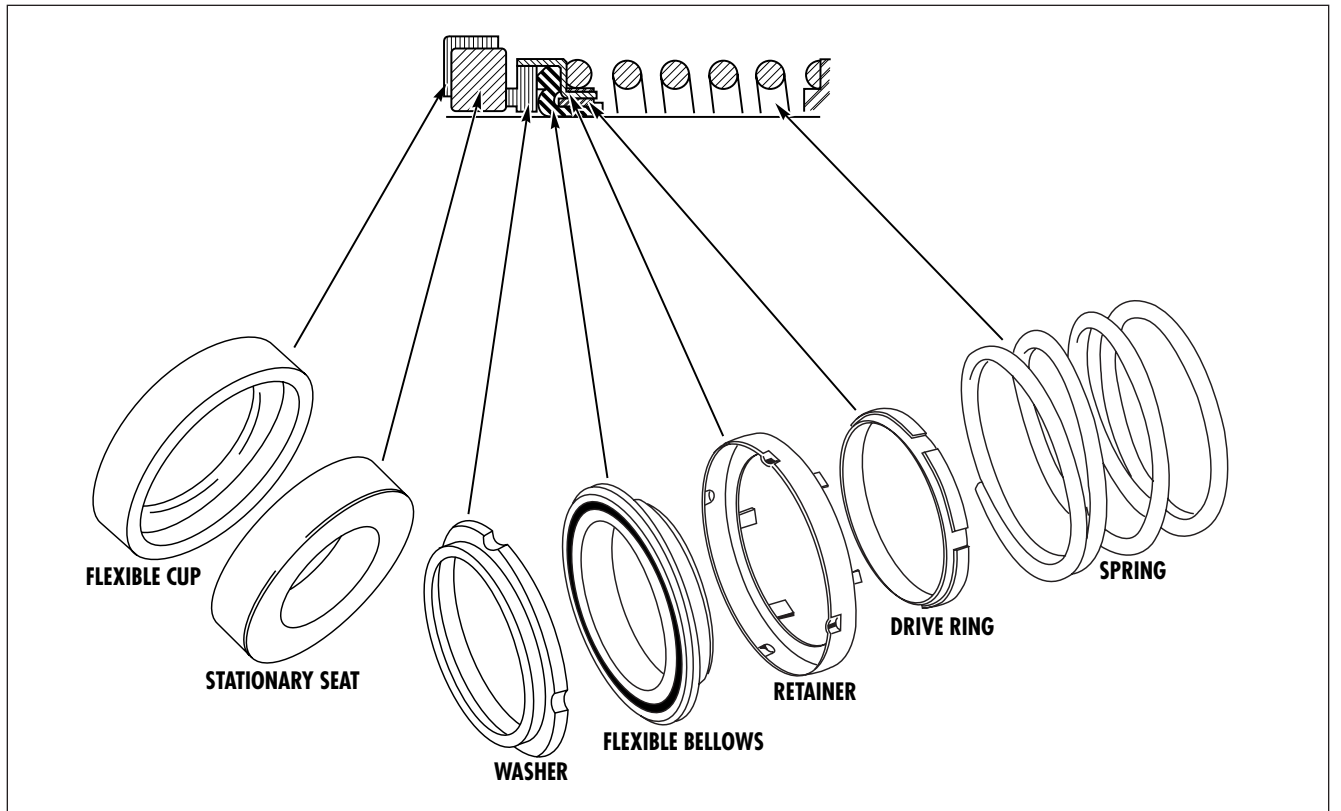

Figure 1. Mechanical Seal

**MODELS 341A-342A-344A**

**MODEL 341A LIST OF PARTS**

- |                   |                   |               |
|-------------------|-------------------|---------------|
| 1. Elbow          | 9A. Washer        | 27. Seal      |
| 2. Connector      | 9B. Gasket        | 32. Capscrew  |
| 3. Tubing         | 9C. Capscrew Seal | 33. Screw     |
| 4. Plug, Pipe     | 10. Gasket        | 34. Nameplate |
| 5. Capscrew       | 11. Impeller      | 35. Bracket   |
| 6. Casing         | 12. Impeller Key  | 39. Capscrew  |
| 7. Wear Ring      | 14. Wear Ring     | 40. Washer    |
| 8. Gasket         | 15. Wear Ring     | 41. Support   |
| 9. Impeller Screw | 16. Wear Ring     | 61. Pin       |
|                   | 25. Sleeve        |               |

**MODEL 342A LIST OF PARTS**

- |                   |                   |                |
|-------------------|-------------------|----------------|
| 1. Elbow          | 9B. Gasket        | 33. Screw      |
| 2. Connector      | 9C. Capscrew Seal | 34. Nameplate  |
| 3. Tubing         | 10. Gasket        | 35. Bracket    |
| 4. Plug, Pipe     | 11. Impeller      | 39. Capscrew   |
| 5. Capscrew       | 12. Impeller Key  | 61. Pin        |
| 6. Casing         | 14. Wear Ring     | 72. Gasket     |
| 7. Wear Ring      | 15. Wear Ring     | 73. Base       |
| 8. Gasket         | 16. Wear Ring     | 74. Plug, Pipe |
| 9. Impeller Screw | 25. Sleeve        | 75. Plug, Pipe |
| 9A. Washer        | 27. Seal          |                |
|                   | 32. Capscrew      |                |

**MODEL 344A LIST OF PARTS**

- |                   |                    |                    |
|-------------------|--------------------|--------------------|
| 1. Elbow          | 25. Sleeve         | 50. O-Ring         |
| 2. Connector      | 27. Seal           | 51. Seal           |
| 3. Tubing         | 32. Capscrew       | 51A. Seal          |
| 4. Plug, Pipe     | 33. Screw          | 52. Retaining Ring |
| 5. Capscrew       | 34. Nameplate      | 53. Bearing        |
| 6. Casing         | 35. Bracket        | 54. Bearing        |
| 7. Wear Ring      | 39. Capscrew       | 55. Shaft          |
| 8. Gasket         | 40. Washer         | 56. Plug, Pipe     |
| 9. Impeller Screw | 41. Support        | 57. Frame          |
| 9A. Washer        | 42. Key            | 58. Grease Fitting |
| 9B. Gasket        | 43. Grease Fitting | 59. Plug, Pipe     |
| 9C. Capscrew Seal | 44. Tube, Vent     | 60. Oiler Assembly |
| 10. Gasket        | 46. Plug, Pipe     | 61. Pin            |
| 11. Impeller      | 47. Slinger        | 62. Capscrew       |
| 12. Impeller Key  | 47A. Slinger       | 63. Washer         |
| 14. Wear Ring     | 48. Capscrew       | 64. Support        |
| 15. Wear Ring     | 49. Bearing Cap    |                    |
| 16. Wear Ring     |                    |                    |

**NOTES:**

1. BRONZE FITTED CONSTRUCTION WILL BE FURNISHED AS STANDARD UNLESS SPECIFIED.
2. REFER TO FACTORY FOR SPECIAL ALLOYS.
3. AURORA PUMP RESERVES THE RIGHT TO SUBSTITUTE MATERIALS WITHOUT NOTICE
4. PIECE NUMBERS 14 AND 15 ARE NOT FURNISHED AS STANDARD, WHEN FURNISHED, IMPELLER MUST BE MODIFIED.
5. PIECE NUMBERS 39, 40, 41 USED ONLY WITH MOTOR FRAMES 143 THRU 184-JM ON MODEL 341A PUMPS.

**NOTE**

**WHEN ORDERING SPARE PARTS ALWAYS INCLUDE THE PUMP TYPE, SIZE, SERIAL NUMBER, AND THE PIECE NUMBER FROM THE EXPLODED VIEW IN THIS MANUAL.**

**ORDER ALL PARTS FROM YOUR LOCAL AUTHORIZED DISTRIBUTOR, FACTORY BRANCH SALES OFFICE OR THE FACTORY AT NORTH AURORA, ILLINOIS.**



MODEL 341A

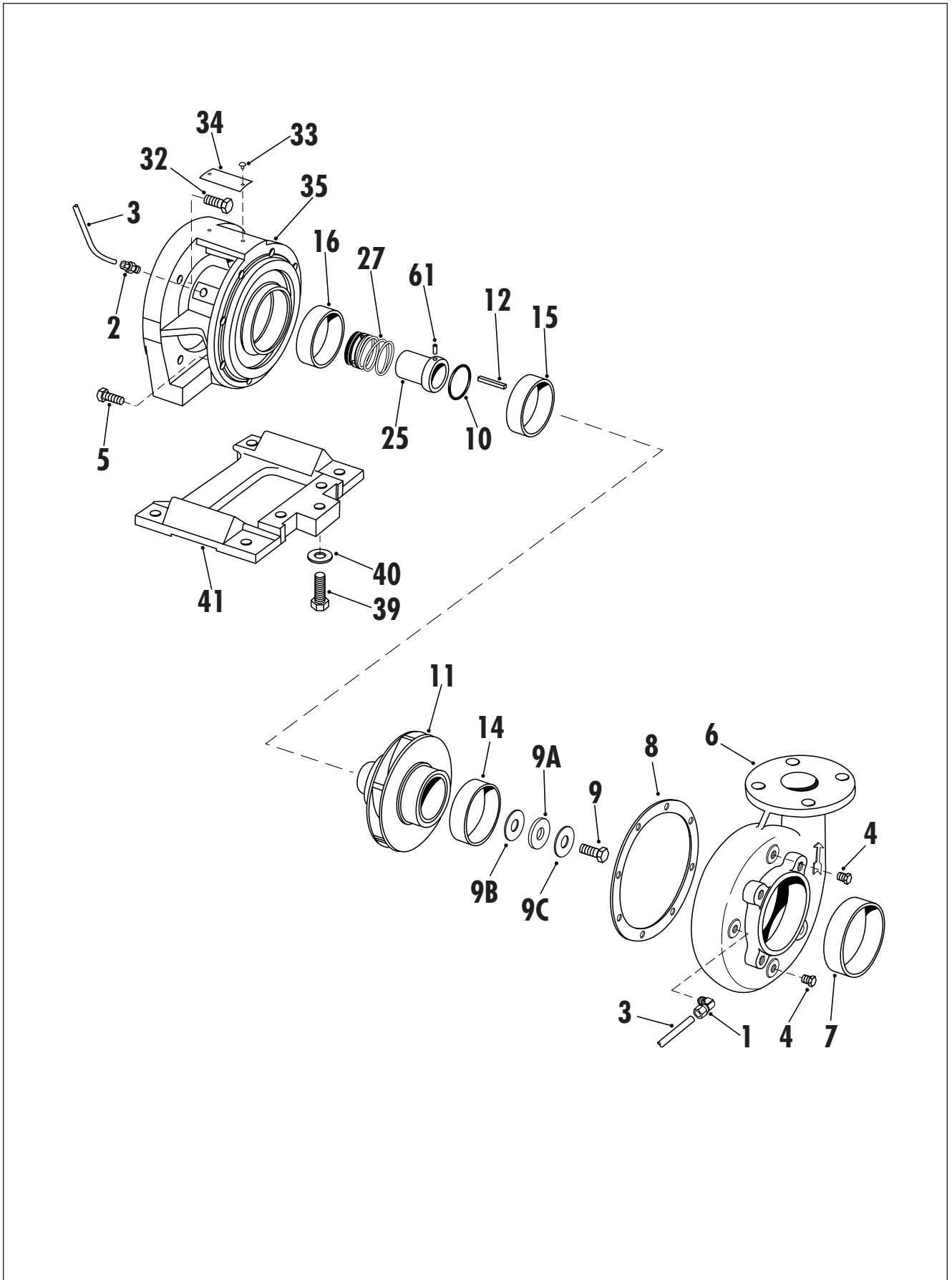

Figure 2. Model 341A Exploded View

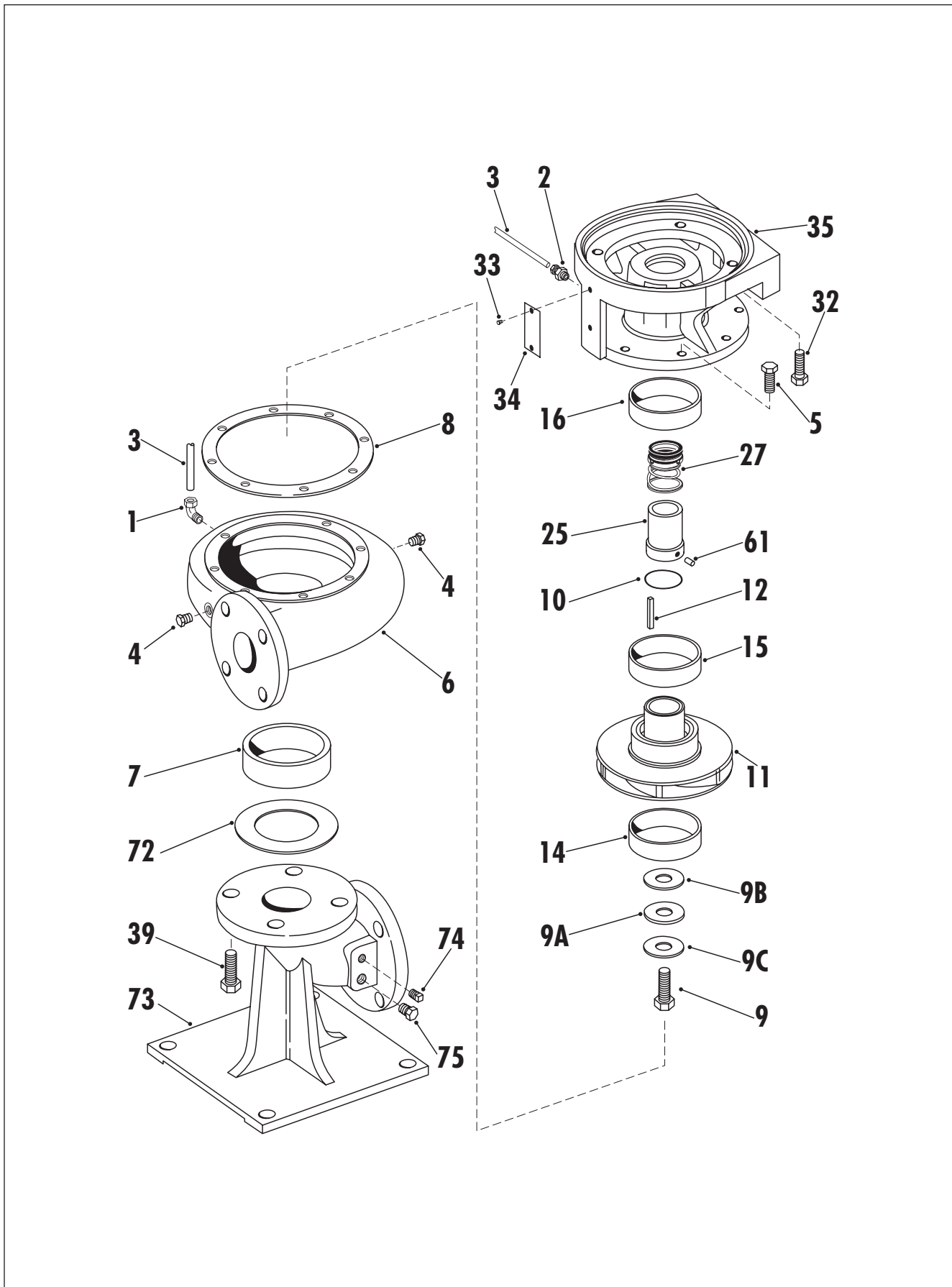

Figure 3. Model 342A Exploded View

MODEL 344A

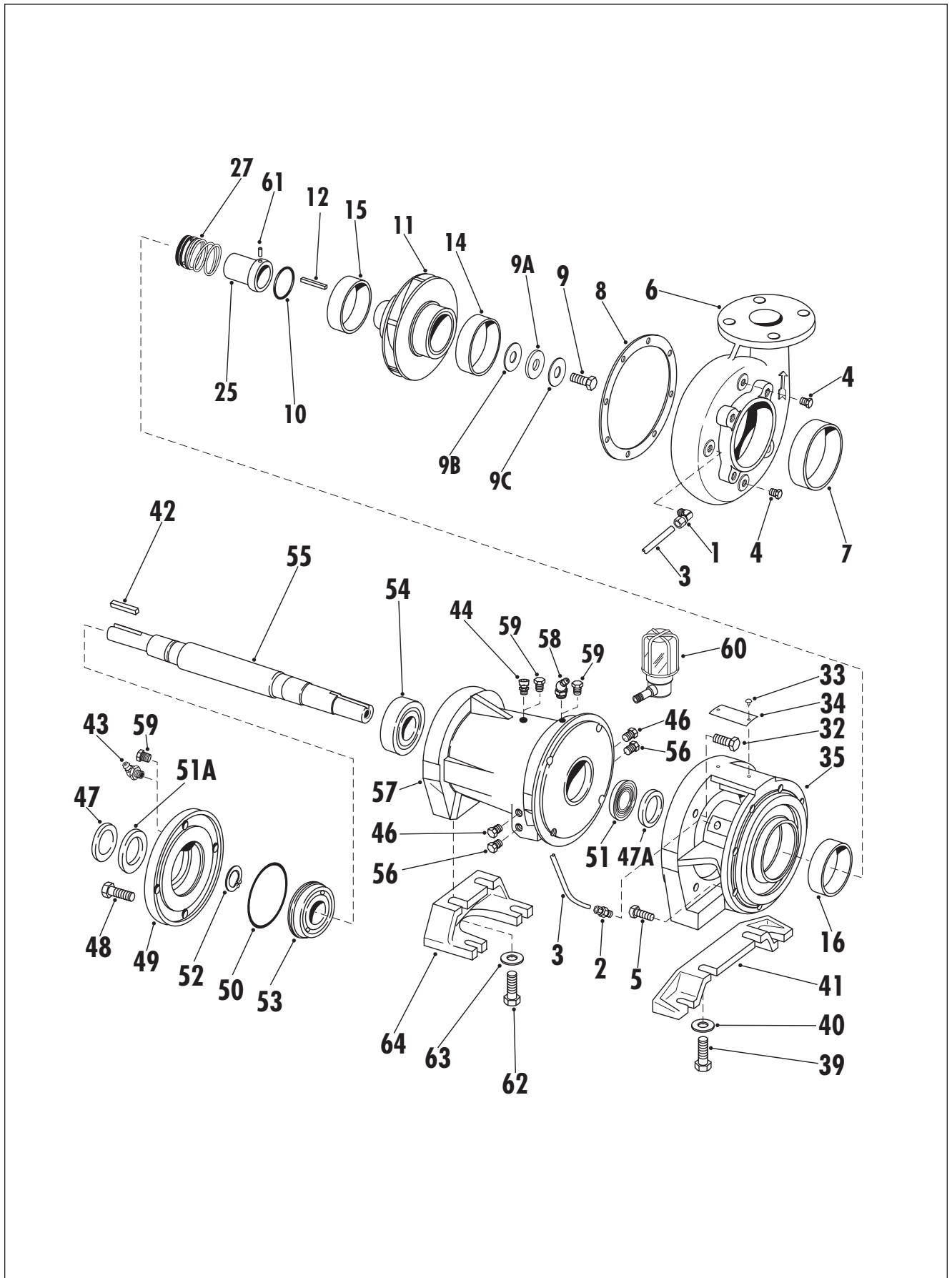

Figure 4. Model 344A Exploded View

## WARRANTY

Seller warrants equipment (and its component parts) of its own manufacture against defects in materials and workmanship under normal use and service for one (1) year from the date of installation or start-up, or for eighteen (18) months after the date of shipment, whichever occurs first. Seller does not warrant accessories or components that are not manufactured by Seller; however, to the extent possible, Seller agrees to assign to Buyer its rights under the original manufacturer's warranty, without recourse to Seller. Buyer must give Seller notice in writing of any alleged defect covered by this warranty (together with all identifying details, including the serial number, the type of equipment, and the date of purchase) within thirty (30) days of the discovery of such defect during the warranty period. No claim made more than 30 days after the expiration of the warranty period shall be valid. Guarantees of performance and warranties are based on the use of original equipment manufactured (OEM) replacement parts. Seller assumes no responsibility or liability if alterations, non-authorized design modifications and/or non-OEM replacement parts are incorporated. If requested by Seller, any equipment (or its component parts) must be promptly returned to Seller prior to any attempted repair, or sent to an authorized service station designated by Seller, and Buyer shall prepay all shipping expenses. Seller shall not be liable for any loss or damage to goods in transit, nor will any warranty claim be valid unless the returned goods are received intact and undamaged as a result of shipment. Repaired or replaced material returned to customer will be shipped F.O.B., Seller's factory. Seller will not give Buyer credit for parts or equipment returned to Seller, and will not accept delivery of any such parts or equipment, unless Buyer has obtained Seller's approval in writing. The warranty extends to repaired or replaced parts of Seller's manufacture for ninety (90) days or for the remainder of the original warranty period applicable to the equipment or parts being repaired or replaced, whichever is greater. This warranty applies to the repaired or replaced part and is not extended to the product or any other component of the product being repaired. Repair parts of its own manufacture sold after the original warranty period are warranted for a period of one (1) year from shipment against defects in materials and workmanship under normal use and service. This warranty applies to the replacement part only and is not extended to the product or any other component of the product being repaired. Seller may substitute new equipment or improve part(s) of any equipment judged defective without further liability. All repairs or services performed by Seller, which are not covered by this warranty, will be charged in accordance with Seller's standard prices then in effect.

THIS WARRANTY IS THE SOLE WARRANTY OF SELLER AND SELLER HEREBY EXPRESSLY DISCLAIMS AND BUYER WAIVES ALL OTHER WARRANTIES EXPRESSED, IMPLIED IN LAW OR IMPLIED IN FACT, INCLUDING ANY WARRANTIES OF MERCHANTABILITY OR FITNESS FOR A PARTICULAR PURPOSE. Seller's sole obligation under this warranty shall be, at its option, to repair or replace any equipment (or its component parts) which has a defect covered by this warranty, or to refund the purchase price of such equipment or part. Under the terms of this warranty, Seller shall not be liable for (a) consequential, collateral, special or liquidated losses or damages; (b) equipment conditions caused by normal wear and tear, abnormal conditions of use, accident, neglect, or misuse of said equipment; (c) the expense of, and loss or damage caused by, repairs or alterations made by anyone other than the Seller; (d) damage caused by abrasive materials, chemicals, scale deposits, corrosion, lightning, improper voltage, mishandling, or other similar conditions; (e) any loss, damage, or expense relating to or resulting from installation, removal or reinstallation of equipment; (f) any labor costs or charges incurred in repairing or replacing defective equipment or parts, including the cost of reinstalling parts that are repaired or replaced by Seller; (g) any expense of shipment of equipment or repaired or replacement parts; or (h) any other loss, damage or expense of any nature.

The above warranty shall not apply to any equipment which may be separately covered by any alternate or special warranties.

**PERFORMANCE:** In the absence of Certified Pump Performance Tests, equipment performance is not warranted or guaranteed. Performance curves and other information submitted to Buyer are approximate and no warranty or guarantee shall be deemed to arise as a result of such submittal. All testing shall be done in accordance with Seller's standard policy under Hydraulic Institute procedures.

**LIABILITY LIMITATIONS:** Under no circumstances shall the Seller have any liability under the Order or otherwise for liquidated damages or for collateral, consequential or special damages or for loss of profits, or for actual losses or for loss of production or progress of construction, regardless of the cause of such damages or losses. In any event, Seller's aggregate total liability under the Order or otherwise shall not exceed the contract price.

**ACTS OF GOD:** Seller shall in no event be liable for delays in delivery of the equipment or other failures to perform caused by fires, acts of God, strikes, labor difficulties, acts of governmental or military authorities, delays in transportation or procuring materials, or causes of any kind beyond Seller's control.

**COMPLIANCE WITH LAW:** Seller agrees to comply with all United States laws and regulations applicable to the manufacturing of the subject equipment. Such compliance shall include: The Fair Labor Standards Acts of 1938, as amended; Equal Employment Opportunity clauses of Executive Order 11246, as amended; Occupational Safety and Health Act of 1970 and the standards promulgated thereunder, if applicable. Since compliance with the various Federal, State, and Local laws and regulations concerning occupational health and safety, pollution or local codes are affected by the use, installation and operation of the equipment and other matters over which Seller has no control, Seller assumes no responsibility for compliance with those laws and regulations, whether by way of indemnity, warranty, or otherwise. It is incumbent upon the Buyer to specify equipment which complies with local codes and ordinances.



**AURORA®**

800 Airport Road  
North Aurora, Illinois 60542  
630-859-7000  
[www.aurorapump.com](http://www.aurorapump.com)