



USER'S GUIDE

CodeLine

End Ported Membrane Housings For Reverse Osmosis

MODEL – 40E60

All information included in this publication is based on the latest information available at the time of printing. Pentair reserves the right to make changes at any time without notice and without incurring any obligation whatsoever. Photocopying of this publication by authorized original equipment manufacturers who have purchased directly from Pentair, or by persons using the materials for legitimate educational purposes, is approved by Pentair. Otherwise all copyright protection afforded by the law applies.

Goa, India. Phone: 91-832-6754400 • Fax: 91-832-6754412

www.codeline.com

DANGER – HIGH PRESSURE DEVICE

This vessel may cause loss of life, severe bodily harm, or property damage if not correctly installed, operated and maintained. Read and understand all guidelines given in this bulleting before attempting to open, operate or service this vessel. Failure to follow these guidelines and observe every precaution will result in malfunction and could result in catastrophic failure. Misuse, incorrect assembly, or use of damaged or corroded components can result in high-velocity release of the end closure. We recommend that only a qualified technician experienced in servicing high-pressure hydraulic systems open, close and service this vessel.

Important Safety Precautions

Do	Do Not
<ul style="list-style-type: none"> • Read, understand and follow every guide- line in this bulletin. Failure to take every precaution may void warranty and could result in catastrophic failure. • Install in an area where a vessel or piping malfunction that result in water leakage would not damage sensitive or expensive equipment, such as electronic components. • Verify that head locking components are properly placed and secured. • Inspect end closures regularly, replace deteriorated components and correct causes of corrosion. • Follow membrane element manufacturer's recommendations for loading elements into the vessel (see Replacing Elements). • The vessel is designed for continuous use at a pH of 3-11 and for intermittent cleaning (max. 43.2 hours per year at a pH of 2-12). • Flush the vessel before system shut down. Some feed waters may cause corrosion under static conditions. Flushing with noncorrosive permeate is recommended. 	<ul style="list-style-type: none"> • Operate the vessel outside the recommended operating and cleaning pH range. • Operate vessel at pressures and temperatures more than their specific rating. • Service any component until you verify that pressure is fully relieved from the vessel. • Use corroded components. Use of such components may result in catastrophic failure. • Pressurize vessel until after visually inspecting to ensure that the spiral retaining rings is correctly installed and seated in their grooves. • Tolerate leaks or allow end closures to be routinely wetted in any way. • Use excessive silicone lubricant. • pressurize vessel without element in place unless permeate ports are plugged internally. • Use vessel at negative pressure. • Pressurize vessel with Compressed Air. • Stand or climb on the pressure vessel, or the feed/ Concentrate or permeate ports. • Allow petroleum or silicone based products to come in contact with membrane elements during installation or maintenance.

General Information

The 40E60 RO Pressure Vessel Housings are designed to be used in water desalination systems. Any make of 4-inch nominal diameter spiral-wound element may be used. The vessels utilize a fiberglass reinforced plastic shell for superior corrosion resistance. However, metallic parts of the vessel may be subject to corrosion, which can result in an unsafe condition. The fiberglass shell can be damaged by rigid clamping, impact, scratches or abrasion.

The information and guidelines incorporated in this User's Guide are intended only as a supplement to good industrial practice. Full responsibility for correct operation and maintenance of vessel remains with the user.

This guide should be used in conjunction with drawing number 518017.

When properly installed and maintained, 40E60 vessels can be expected to provide safe operation over a long service life.

INSTALLATION

Regardless of when or by whom your vessel may have been installed, there are a few quick checks you should make before use. Check that each vessel is:

- Mounted with compliant material (Polyurethane saddle) between the fiberglass shell and any rigid frame.
- Free to expand under pressure - shell not clamped rigidly in place, no rigid piping connections to port fittings.
- Not used in any way to support other components such as piping, manifolds hanging from ports.

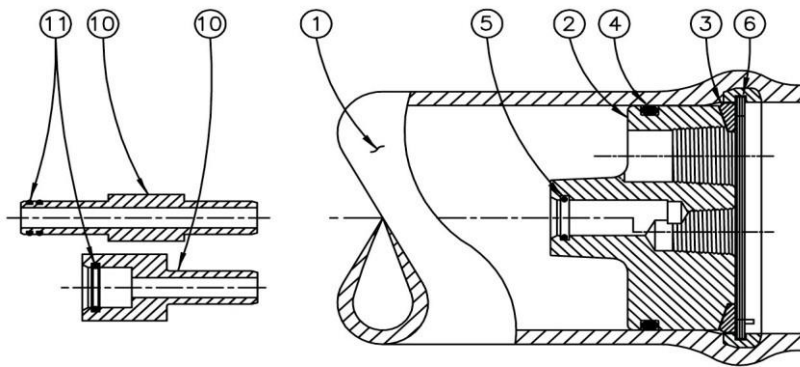

Figure 1: Section Through End Closure

Dwg Ref	Qty Per	Item #	Description	Materials
Shell				
1	1		Shell	Filament Wound epoxy/glass composite. Head locking grooves internally wound in place. Shell exterior coated with white high gloss polyurethane paint.
Head				
2	2	50420	End Plug	Engineering Thermoplastic
3	2	50440	Bearing Ring	Nickel Plated Alloy Steel
4	2	196266	Plug Seal	Ethylene Propylene O-ring
5	2	196431	Adapter Seal	Ethylene Propylene O-ring
Head Interlock				
6	2	45260	Retaining Ring	316 SST
10	2	A/R	Adapter	Engineering Thermoplastic
11	A/R	A/R	PWT Seal	Ethylene polypropylene O-ring
Vessel Support				
7*	2**	45058	Saddle	Engineering Thermoplastic
8*	2**	47459	Strap Assembly	304 SST - PVC Cushion
9*	4	47458	Strap Screw	5/16-18 UNC, 18-8 SST
* Note items 7,8 and 9 not shown in the above cross section				
** 3 each furnished with length code 4,5 and 6				

OPENING THE VESSEL

WARNING

Relieve pressure from vessel before beginning this procedure.

Contamination Removal

Metal oxidation products and mineral deposits can interfere with vessel disassembly. Remove all foreign matter from both ends of vessel as follows:

1. Remove contaminants using a small wire brush or suitable abrasive (such as medium-grade ScotchBrite™).



Cleaning inside the vessel

2. Flush away loosened deposits with clean water.

Removing the Head

The head assembly is shown in Figure 1.

Remove head as follows:

Disconnect Permeate Piping -

1. Disconnect permeate piping as required at nearest convenient joint, being careful not to place undue stress on the threaded connections of the plastic permeate port(s).

CAUTION

DO NOT tap on fittings as this could damage the ports.

Remove the Retaining Ring from the groove –

1. Lift the tabbed end of the retaining ring up out of the stainless-steel groove in the shell and then away from the head so that it rests in the end margin of the vessel. This is best accomplished by using CodeLine Removal Tool, part number 50303, which is available from your supplier.

This can also be accomplished using a screwdriver and a pair of pliers if the tool is not readily available.

With the removal tool the retaining ring can be lifted upward by simply rotating the tool counterclockwise after inserting it over the tab on the retaining ring. (Use the smaller hole). Hold the tool flat against the end margin and parallel to the vessel bore. It is then possible to pull the end of the retaining ring straight out. The retaining ring snap back into the groove if this alignment is not closely adhered to. If the retaining ring is difficult to remove, try soaking with a release agent such as LPS™ or WD40™, being careful to avoid any contamination of a membrane element.



Retaining Ring Removal Tool

When using screwdriver and pliers, pry the tabbed end of the retaining ring out of the stainless-steel groove with the tip of the screwdriver. Once the end of the retaining ring is clear of the groove, grab the tab with the pliers and pull towards the end of the vessel until the end of the ring is resting in the end margin of the shell.

2. Remove the 4" retaining ring from the stainless groove in the shell by rotating your finger behind the ring as it continues to exit the groove.



Removal of Retaining Ring

OPENING THE VESSEL (CONTD...)

Once the retaining ring has been removed, examine the area for burrs or dings which could damage the head or membrane. If necessary, use ScotchBrite™ or 600 grade sandpapers to smooth the area.

Removing Head Assembly –

1. Using a mallet, tap the head assembly lightly. Do not use a metal component to tap the head assembly.
2. Install a ½”NPT x 6” long nipple into the product port of the head on one end of the vessel.
3. Grasp the nipple and pull the head straight out. A small amount of side-to-side movement may be necessary to move the end plug. Care should be taken to avoid placing too much stress on the product port threads.



Removal of Head Assembly

4. Remove and discard plug seal, taking care not to scratch or otherwise damage the sealing surfaces.
5. Repeat above procedure for the opposite end of the vessel.
6. As soon as possible after removal, disassemble and check all head components, as described in Rebuilding the Head and Refurbishing Parts.

REPLACING ELEMENTS

The following procedures are provided for information only. Elements should be installed in accordance with the element manufacturer's recommendations. Where conflicts exist, contact the element manufacturer or Pentair Water for clarification.

Removing Elements

1. Remove heads from both ends of vessels as described in Opening the Vessel.

NOTE

Always remove and install element in the direction of feed flow. The feed end (upstream end) is the end plumbed most directly to the pump.

2. Push element out of vessel from the upstream end.
3. For multi-element vessels, remove the inter-connectors and retain for reinstallation.

Inserting Elements

1. Ensure that heads are available in clean, as-new condition before proceeding. (If in doubt as to head condition see section on inspecting parts, page 10).
2. Check that all required elements are ready for assembly, with no dings or other damage which could scratch the inside of the vessel.
3. Check that the interior of the vessel is clean and free of burrs, sharp edges or other damage. Remove any residual lubricant from the vessel bore and work a fresh, thin film of Parker-Super O-Lube™ lubricant into the lead-in chamfer and an area approximately ½ inch in from the chamfer.

CAUTION

When lubricating the vessel chamfer, wear protective gloves or finger cots to prevent cuts or penetration of fiberglass.

4. Install adapter if required into one end plug. At downstream end of vessel, orient end plug ports into desired position and push plug fully into vessel. A sharp, forceful thrust may be needed to enter plug seal into the vessel bore.



Installation of the End Plug Assembly into the vessel

5. Carefully insert retaining ring into its groove. This is done by inserting the lead end of the spiral retaining ring (end without bent tab) into the stainless-steel retaining ring groove located in the shell, and slowly pushing the remaining



Inserting Retaining Ring into the groove

6. Check that the spiral retaining ring is fully seated in the groove. If it is not, remove and check for foreign material that is causing the spiral ring not to sit into the groove.



Retaining ring seated in the groove

REPLACING ELEMENTS (CONTD...)

7. Lubricate element seals sparingly with the element manufacturers recommended lubricant or with glycerin.
8. Insert each element with the brine seal (typically a U-cup seat) installed on the upstream end with its lip facing upstream.

CAUTION

System malfunctions and element damage may result if elements are installed in the wrong direction.

9. Install the interconnectors between multiple elements as each succeeding element is installed.

NOTE

On some systems it may be easier to install the piping connections before the head is installed. If so, please proceed with Steps 10 & 11.

10. Push each element downstream into the shell as it is installed until the element is fully engaged with the downstream head. If the elements are hard to push, make sure the brine seal is properly installed and you are pushing from the upstream end.
When all the elements are fully inserted into the vessel, install the upstream head with the adapter fitted if required, as described in paragraphs 4 to 6 on page 6.
11. Reconnect piping to vessel as described in Remaking Pipe Connection to End Plug on page 10.
12. Pressurize the vessel. Inspect for leaks at connections to the vessel and all around the vessel itself. If any leaks occur, release pressure from the vessel and tighten the fittings as necessary. Then pressurize vessel and check for leaks again.

CAUTION

DO NOT tolerate any leaks. Leaks can result in corrosion and eventual catastrophic vessel failure.

HEAD ASSEMBLY

NOTE

Head Rebuilding should be performed in a clean work area. Dust or dirt on O-rings or other parts can scratch inner surfaces, with subsequent leakage.

1. Using a small screwdriver or similar tool remove the Plug Seal. However, do not damage the sealing surface in any way as it may lead to leakage.
2. Using a small screwdriver or similar tool remove the PWT Seal from the groove in the end plug.

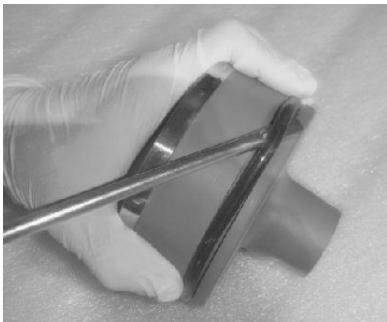

Removal of the Plug Seal



Removal of the PWT Seal

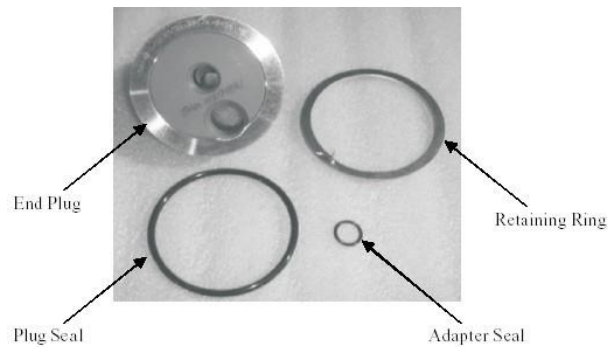

Head Component Identification – Head Disassembled

HEAD ASSEMBLY (CONTD...)

1. Use only head components in as-new condition. Use new O-rings each time the head is assembled.
2. Cover O-rings with a thin even layer of Parker Super O-Lube™ silicone lubricant or the lubricant recommended by your element supplier.



Lubricating Plug seals and O-rings

NOTE

Glycerin is a commercially available lubricant that will not foul elements. However, silicone lubricant is recommended for this application.

3. Assemble the Adapter Seal into the groove in the End Plug.



Installing PWT Seal

4. Insert the Head Seal O-ring into the groove on the outside diameter of the End Plug.

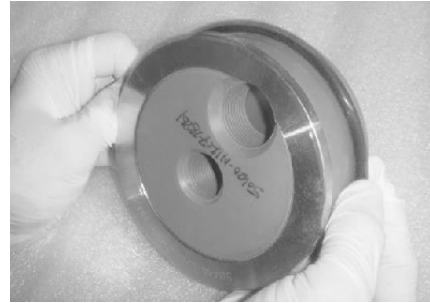

Installing Plug Seal

5. Protect heads from contamination until ready to assemble into the vessel(s).

REFURBISHING PARTS

Inspecting Parts -

Plastic parts: examine for cracking, softening or discoloring. This may indicate chemical attack of the material. Defective parts must be replaced. Alternatematerial may be required. Contact your supplier or Pentair Water for assistance.

Metal parts: check for corrosion, scratches, dents, cracks or other damages to insert ring and spiral retaining ring.

Other parts: examine for any damage, such as gouges, chips or cracks, that could affect structural strength or sealing characteristics. The following are some examples of defects that may require replacement of the affected part -

- End Plug: cracked, discolored, sealing areas damaged (chipped or gouged), threads stripped or cross-threaded.
- Spiral Retaining rings: are the sole means of end plug retention. Parts bent, corroded, cracked, or damaged in any way must not be used. Carefully check for hairline cracks.

Refurbishing Shell –

1. Using a fine wire brush, remove any large deposits from locking ring groove in the shell.
2. Using a medium or finer grade of ScotchBrite™ and mild soap solution, clean the inside of the vessel at least 4 inches in from each end.
3. Use clean water to rinse away all loosened deposits and soap residue.
4. Examine inside of vessel for scratches, gouges, or other imperfections that could prevent proper sealing. If such areas exist and leaks are observed when the vessel is placed back in service, the shell may need to be replaced.

Refurbishing Other Parts –

1. Remove any large deposits from metal parts using a wire brush.
2. Scrub the entire surface with medium grade ScotchBrite™ until all contaminants are removed.
3. Rinse parts clean with fresh water and dry.
4. Inspect all parts for serviceability as specified above.

Remaking Pipe Connection to End plug -

1. Use a wire brush to remove all foreign matter from threads on pipe fittings.
2. Apply non-hardening thread sealant or Teflon™ tape to fitting and install into end plug. Tighten each fitting a maximum one quarter-turn past hand tight; the plastic end plug could be damaged if fittings are over-tightened.
3. Fit end plug and retaining ring as described in Replacing the Elements section on page 6 and 7.

Part Replacement –

Replace all parts that cannot be restored to as-new condition.

Replace any parts showing signs of structural damage or corrosion.

CAUTION: Use of components damaged by corrosion can cause catastrophic failure.

Seals should be replaced as necessary each time the vessel is serviced. Any parts that need to be replaced are available from your supplier or from Pentair.

NOTE
AFTER END OF SERVICE LIFE OF VESSEL, DISPOSE THE VESSEL AND ITS COMPONENTS
AS PER APPLICABLE LOCAL LAWS AND REGULATIONS

WARRANTY TERMS & CONDITION

FOR LATEST WARRANTY TERMS & CONDITIONS VISIT ON
<https://codeline.pentair.com/en/downloads> (Document Name - Warranty Terms & Conditions - Pentair Warranty FRP Housings)

