

FX-12E EMPTY SYSTEM

Part Number: FX-12E: 160-50202



APPLICATIONS

- ◆ Fountain beverages
- ◆ Drinking water
- ◆ Coffee
- ◆ Tea

SYSTEM DESCRIPTION

The FX-12E empty water filtration system for foodservice applications allows the flexibility to choose the appropriate filter cartridge to fit your needs. The system includes the mounting bracket, mounting hardware, pressure gauge, inlet shut-off valve, and sump.

FEATURES • BENEFITS

- ◆ Sturdy mounting bracket and full-flow inlet shut-off valve simplify installation
- ◆ Built-in pressure gauge allows visual monitoring when filters need to be changed
- ◆ Inlet shut-off and depressurization valves make filter replacement quick and simple
- ◆ Minimizes waste by only replacing drop-in cartridge and reusing filter sump

INSTALLATION TIPS

- ◆ Choose a mounting location suitable to support the weight of the system while operating.
- ◆ Install vertically and allow 2½" (6.35 cm) clearance below the sump for easy removal and replacement.
- ◆ Feed water temperature must not exceed 100°F (38°C).
- ◆ Do not install where the system could be exposed to freezing temperatures.
- ◆ Feed water supply pressure must not exceed 125 psi (non-shock). When pressure exceeds 85 psi, a pressure reducing valve is recommended.
- ◆ Detailed installation, operation and maintenance manual included with the system.

FX-12E EMPTY SYSTEM

160-50202

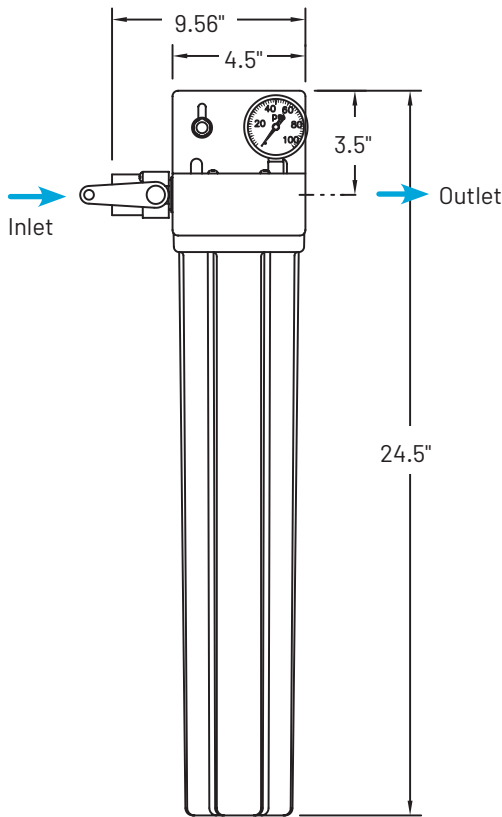

SPECIFICATIONS

System

Overall Dimensions

24.5" L 9.56" W 5.1" D
(62.23 cm x 24.89 cm x 12.95 cm)

Connections

Inlet Connection: 1/2" FNPT
Outlet Connection: 1/2" FNPT

Operating Pressure

10 - 125 psi (0.7 - 8.6 bar)

Water Temperature

35 - 100°F (2 - 38°C)

Shipping Weight

8 lbs (3.63 kgs)

Electrical Connection

None required

For Pentair Everpure Product Warranties visit:
<http://pentair.com/assets/foodservice-warranty>

It is recommended that filter cartridges be replaced every six (6) months on a regular scheduled program, or when capacity is reached or if water pressure or flow to equipment becomes inadequate.

Always replace filter cartridges at least once per year.

The contaminants or other substances removed or reduced by this drinking water system are not necessarily in your water. Do not use with water that is microbiologically unsafe or of unknown quality without adequate disinfection before or after the system.

Systems certified for cyst reduction may be used on disinfected water that may contain filterable cysts.

Since the conditions under which our products may be used are beyond our control, we cannot accept any liability with respect to the improper installation, application and/or use of our products.



United States | 1040 Muirfield Drive | Hanover Park, IL 60133 | 800.942.1153 (US Only) 630.307.3000 Main | cseverpure@pentair.com | foodservice.pentair.com
Australia | 1-21 Monash Drive | Dandenong South, Vic 3175 | Australia | 011.1300 576 190 Tel | au.everpure@pentair.com
China | 21F Cloud 9 Plaza, NO 1118 | Shanghai, 200052 | China | 86.21.3211.4588 Tel | china.water@pentair.com
India | Boulevard, B-9/A, 7th Floor - Tower B Sector 62 | Noida - 201301 | 91.120.419.9444 Tel | indiacustomer@pentair.com
Europe | Pentair Water Belgium BVBA | Industriepark Wolfstee, Toekomstlaan 30, B-2200 Herentals | Belgium | +32.(0).14.283.504 Tel | sales@everpure-europe.com
Japan | Japan Inc. | Hashimoto MN Bldg. 7F, | 3-25-1 Hashimoto, Midori-ku, Sagami-hara-shi | Kanagawa 252-0143 | Japan | 81.(0)42.775.3011 Tel | info@everpure.co.jp
Southeast Asia | 390 Havelock Road, | #04-01 King's Centre | Singapore 169662 | 65.6768.5800 Tel | cseverpure@pentair.com

All indicated Pentair trademarks and logos are property of Pentair. Third party registered and unregistered trademarks and logos are the property of their respective owners.

©2021 Pentair. All Rights Reserved.

160-50202 DE21