



► FROM PENTAIR WATER SOLUTIONS

# QT11+CR WATER FILTRATION SYSTEM

System Part Number: 170-52081



## SYSTEM DESCRIPTION

The **QT11+CR** is a dual cartridge water filtration system with two Qwik-Twist cartridges. Gradient-density media filters sediment particles as small as 0.5 micron while minimizing chloramines, chlorine and taste & odors at a flow rate of 2.5 gpm and up to 20,000 gallons. An additional built-in scale inhibitor can help extend equipment longevity and ensure optimum performance and efficiency.

## FEATURES • BENEFITS

- ◆ IsoNet® - patented scale-inhibiting technology
- ◆ Gradient-density sediment filtration reduces dirt, rust and other debris
- ◆ CTO-Q10 cartridge - Activated carbon filtration reduces chlorine, taste & odors
- ◆ CTOS-QCR cartridge - Catalytic carbon provides chloramine reduction
- ◆ Sturdy, powder-coated mounting bracket and multi-function valve simplify installation
- ◆ Multi-function valve provides:
  - Shutoff valve for easy cartridge replacement
  - System bypass valve for easy system maintenance
  - Flush port to flush cartridges after installation
- ◆ Built-in pressure gauge provides a visual indicator for monitoring of when filters need to be changed
- ◆ Qwik-Twist cartridges

## APPLICATIONS

- ◆ Steam
- ◆ Combi ovens

## INSTALLATION TIPS

- ◆ Choose a mounting location suitable to support the weight of the system while operating.
- ◆ Install vertically and allow 3" (7.62 cm) clearance below the cartridge for easy removal and replacement.
- ◆ To be used for treated water connection only.
- ◆ Do not exceed system specifications for temperature and pressure.
- ◆ Do not install where the system could be exposed to freezing temperatures.
- ◆ For more details, see the installation, operation, and maintenance guide included with the system.

# QTI1+CR

170-52081

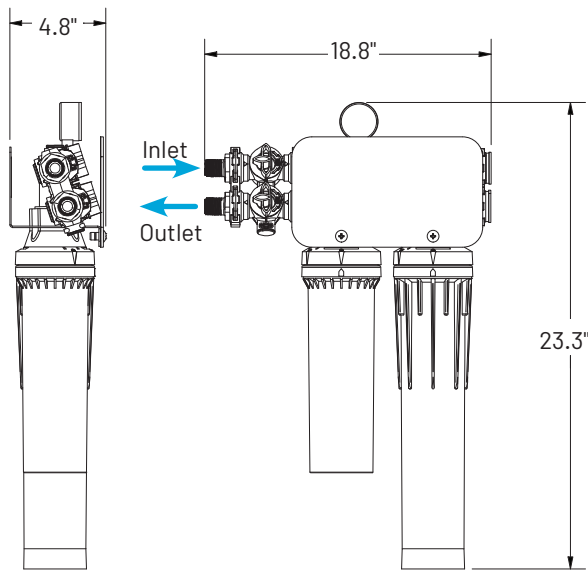

## SPECIFICATIONS

System	Performance
<b>Overall Dimensions</b> 23.3" H x 18.8" W x 4.8" D (59.2 cm x 36.3 cm x 12.2 cm)	<b>Service Flow Rate</b> Maximum 2.5 gpm (9.5 Lpm)
<b>Connections</b> Inlet Connection: 1/2" MNPT Outlet Connection: 1/2" MNPT	<b>Rated Capacity</b> 20,000 gallons (75,708 L)
<b>Operating Pressure</b> 20 - 125 psi (1.4 - 8.6 bar) non-shock	<b>Chlorine, Taste &amp; Odor Reduction</b> Yes
<b>Water Temperature</b> 35 - 100°F (2 - 38°C)	<b>Chloramines Reduction</b> Yes
<b>Operating Weight</b> 7.5 lbs (3.4 kgs)	<b>Particulate Reduction</b> Yes
<b>Shipping Weight</b> 9 lbs (4.1 kgs)	<b>Scale Reduction</b> Yes
<b>Electrical Connection</b> None required	

## REPLACEMENT CARTRIDGES

Model	Qty	Description	Part No
CTO-Q10	1	Pre/Post-filter	300-05828
CTOS-QCR	1	Primary Chloramine filter	300-05832

For Pentair Everpure Product Warranties visit:  
<http://pentair.com/assets/foodservice-warranty>

It is recommended that filter cartridges be replaced every six (6) months on a regular scheduled program, or when capacity is reached or if water pressure or flow to equipment becomes inadequate.

Always replace filter cartridges at least once per year.

The contaminants or other substances removed or reduced by this drinking water system are not necessarily in your water. Do not use with water that is microbiologically unsafe or of unknown quality without adequate disinfection before or after the system.



1040 Muirfield Drive | Hanover Park, IL 60133 | 800.942.1153 (US Only) 630.307.3000 Main | [cseverpure@pentair.com](mailto:cseverpure@pentair.com) | [foodservice.pentair.com](http://foodservice.pentair.com)

All indicated Pentair trademarks and logos are property of Pentair. Third party registered and unregistered trademarks and logos are the property of their respective owners.

©2024 Pentair. All rights reserved.

170-52081 AP24