



SHURFLO® 8075 HIGH PERFORMANCE BRUSHLESS D.C. RO BOOSTER PUMP

ROBUST, VERSATILE, LONG-LIFE PUMP DESIGNED FOR DEMANDING COMMERCIAL RO APPLICATIONS

Pump: 8075-192-319



APPLICATIONS

Reverse Osmosis (RO)

FEATURES • BENEFITS

One (1)-piece piston diaphragm

Precision bypass system maintains a constant safe outlet pressure

Extended motor life with brushless technology

Ultra quiet operation at any flow and pressure range

Unique, two (2)-speed switch

Meets the performance requirements of 150 or 200 gpd (568 or 757 Lpd)

Self-priming up to 8 ft (2.44 m) vertical

Can run dry without damage

INSTALLATION TIPS

Ideal for high flow, high pressure applications.

Can be mounted in any position.

OPERATION TIPS

Can run dry without damage.

Self-priming.

SIZING

High Flow Rate: supports 150 - 200 gpd (568 - 757 Lpd) systems at standard recovery rates.

Pressures: up to 140 psi (9.6 bar)

SHURFLO® RO BOOSTER PUMP

8075-192-319

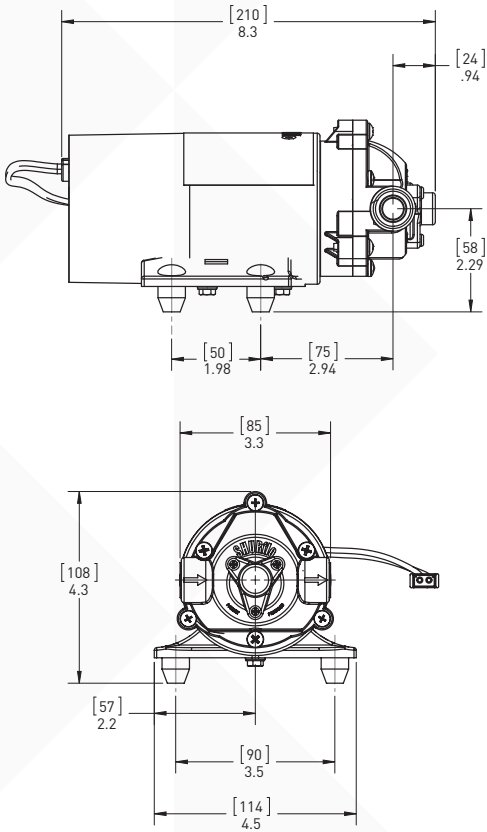

SPECIFICATIONS

Motor

24 VAC/VDC brushless with switch selector for 150 gpd (568 Lpd) or 200 gpd (757 Lpd)

Permanent Magnet, P/N 11-295-00

Pump Design

Positive displacement/three chamber solid diaphragm pump

Cam: 2.5 Degree

Ports

3/8" (10 mm) NPT female

Pressure Requirements

Max Inlet pressure: 80 psi

Liquid Temperature Range

34 – 125°F (1 C – 82°C)

Materials of Construction

Plastics: Nylon
Valves & O-Ring: Viton
Diaphragm: Santoprene
Fasteners: Stainless Steel

Net Weight

5.1 lbs (2.3 kgs)

Duty Cycle

Continuous

Approvals

NSF listed

Max. Amp Draw

2.2 amps 150 gpd (568 Lpd) operation @ 20 psi (1.4 bar) inlet and 140 psi (9.6 bar) outlet

2.5 amps 200 gpd (757 Lpd) operation @ 20 psi (1.4 bar) inlet and 120 psi (8.3 bar) outlet

Electrical

24 VAC/VDC; Power Supply required

Bypass

140 PSI (9.65 bar)

Pack Size

6/case

Performance: 150 GPD [570 LPD]

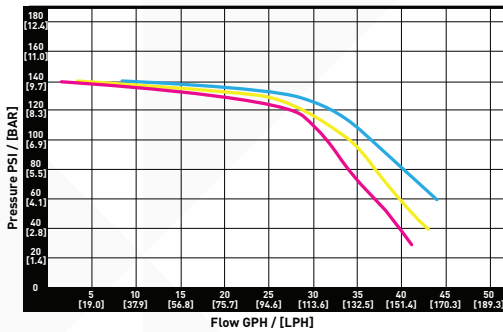

■ 20 PSI / [1.4 BAR] ■ 40 PSI / [2.8 BAR] ■ 60 PSI / [4.1 BAR]
(City Water Inlet Pressure)

Performance: 200 GPD [760 LPD]

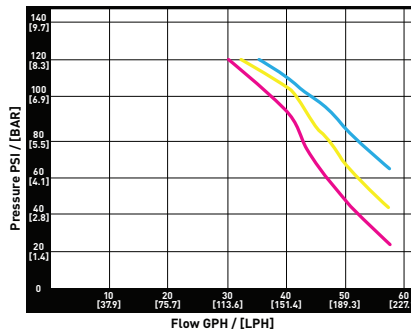

■ 20 PSI / [1.4 BAR] ■ 40 PSI / [2.8 BAR] ■ 60 PSI / [4.1 BAR]
(City Water Inlet Pressure)

WARRANTY

One Year Limited Pentair® Warranty on 8075 Series Pumps is valid from the date of manufacture or with proof of purchase. Pentair will provide a copy of the warranty upon request.



WATER QUALITY SYSTEMS

EVERPURE-SHURFLO WORLD HEADQUARTERS, 1040 MUIRFIELD DRIVE, HANOVER PARK, IL 60133 USA • FOODSERVICE.PENTAIR.COM
800.942.1153 (US ONLY) • 630.307.3000 MAIN • 630.307.3030 FAX • CSEVERPURE@PENTAIR.COM EMAIL

All Pentair trademarks and logos are owned by Pentair, Inc. or its affiliates. All other registered and unregistered trademarks and logos are the property of their respective owners. Because we are continuously improving our products and services, Pentair reserves the right to change specifications without prior notice. Pentair is an equal opportunity employer.