

# FRESHPOINT® GRO-575B

## FIVE STAGE REVERSE OSMOSIS SYSTEM



### APPLICATIONS

- ◆ Drinking water

### FEATURES • BENEFITS

- ◆ Certified to reduce up to 99.7% of Total PFAS\*\*
- ◆ Reduces more than 90% of contaminants found in water
- ◆ Effortless click-in cartridge change-outs
- ◆ Color-coded cartridges help maintain proper filter sequence
- ◆ 3/8" push fittings for easy installation
- ◆ High efficiency membrane technology delivers up to 75 gallons per day

### INSTALLATION TIPS

- ◆ Choose a mounting location suitable to support the full weight of the system when operating.
- ◆ Install vertically with the cartridge hanging down.
- ◆ System may be installed with cartridge flush to the baseboard if desired as the mechanical assist lever pushes cartridges straight out.

### OPERATION TIPS

- ◆ Replace pre/post filters every year and RO membrane every 18 months.
- ◆ Place replacement cartridges in proper sequence utilizing color-coded shapes.
- ◆ System is designed with integrated check valves so cold water line does not need to be shut off to perform cartridge change-outs.

### INCLUDES

- ◆ Air gap side faucet
- ◆ Installation kit
- ◆ Installation and operation manual
- ◆ 4.4 gallon storage tank

# FRESHPOINT GRO-575B FIVE STAGE REVERSE OSMOSIS SYSTEM

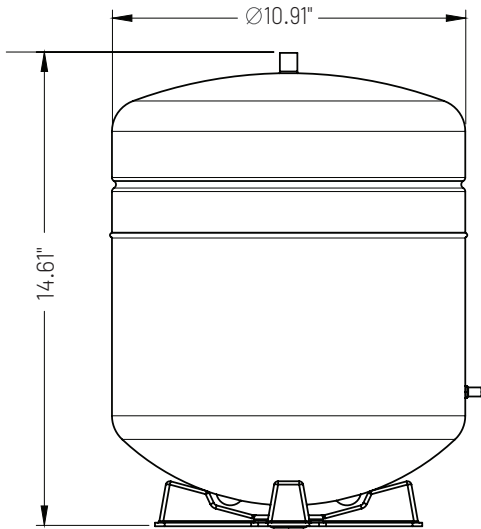
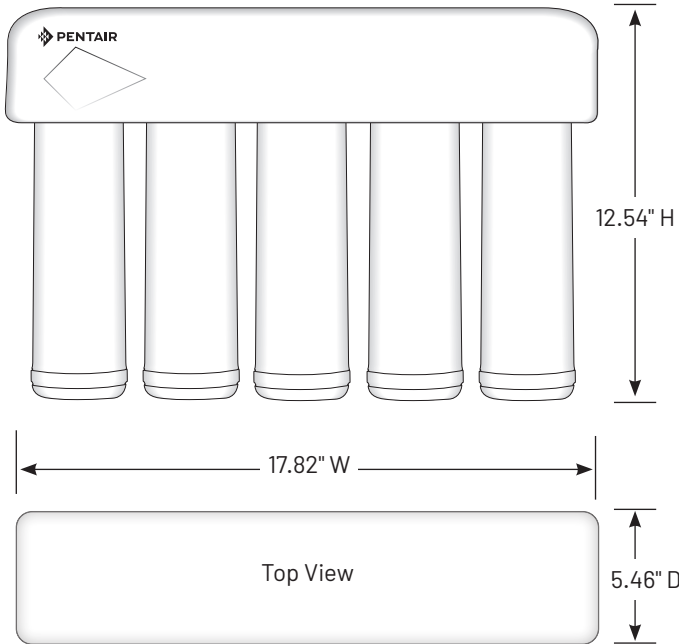

## SPECIFICATIONS

- ◆ **System** (Model/Part No.)  
GRO-575B/161112
- ◆ **Inlet Size**  
3/8" QC
- ◆ **Dimensions**  
17.82" W x 5.46" D x 12.54" H  
(453 mm x 139 mm x 319 mm)
- ◆ **System Weight**  
10.70 lbs (4.85 kg))
- ◆ **Contaminant Reduction**  
Chlorine Taste & Odor  
Nominal Particulate Class I  
Atrazine  
Lead  
Lindane  
Arsenic (Pentavalent) <= 50 ppb  
Barium  
Cadmium  
Chromium (Hexavalent)  
Chromium (Trivalent)  
Copper  
Fluoride  
Radium 226/228  
Selenium  
Turbidity  
TDS  
VOCs  
Total PFAS  
Cysts: NSF/ANSI Standards 53 and 58 certified to reduce cysts such as Cryptosporidium and Giardia by mechanical means.
- ◆ **TDS Rejection**  
95.5%
- ◆ **Approximate Filter Life\***  
Pre/Post Filters: 1 year  
RO Membrane: 18 months
- ◆ **Capacity**  
675 Gallons (2,555.15 liters)
- ◆ **System Production Rate**  
21.08 gpd (79.77 Lpd)
- ◆ **Recovery Rating**  
51.17%
- ◆ **Certifications**  
NSF/ANSI Standards 42/53/58  
CSA Standard B483.1
- ◆ **Feed Pressure Range**  
40 - 100 psi (2.75 - 6.89 bar)
- ◆ **Temperature Range**  
40 - 100°F (4.4 - 37.8°C)
- ◆ **Replacement Cartridges** (Model/Part No.)  
F1GC-RC/655117-96  
FDF1-RC/655123-96  
F2B2-RC2/655126-96 (twin pack)  
GRO75-RC/655122-96

\* Filter life dependent on gallon usage and overall incoming water quality.

EPA Est. No. 082989-CHN-001



The Model GRO-575B is Tested and Certified by NSF International against NSF/ANSI Standards 42, 53, 58 and CSA B483.1 for the reduction of substances specified in the service manual or at [www.nsf.org](http://www.nsf.org).



The Model GRO-575B is certified by IAPMO R&T against NSF/ANSI 53 for the reduction of Total PFAS.\*\*

\*\*The test mixture for total PFAS is made up of PFOA (500 ppt), PFOS (1,000 ppt), PFHxS (300 ppt), PFNA (50 ppt), PFHpA (40 ppt), PFBS (260 ppt), and PFDA (10 ppt). This system meets the 20 ppt requirement for Total PFAS.



### Pentair Residential Filtration

13845 Bishops Dr. | Suite 200 | Brookfield, WI 53005 | United States  
P: 262.238.4400 | Customer Service: 800.279.9404 | [tech-support@pentair.com](mailto:tech-support@pentair.com) | [pentair.com](http://pentair.com)

All indicated Pentair trademarks and logos are property of Pentair. Third party registered and unregistered trademarks and logos are the property of their respective owners.