



KREEPY KRAULY[®] PROWLER[®] 820 AND 830 ROBOTIC INGROUND POOL CLEANERS



INSTALLATION AND USER'S GUIDE

IMPORTANT SAFETY INSTRUCTIONS
READ AND FOLLOW ALL INSTRUCTIONS
SAVE THESE INSTRUCTIONS

CUSTOMER SERVICE / TECHNICAL SUPPORT

If you have questions about ordering Pentair Aquatic Systems replacement parts, and pool products, please use the following contact information:

Customer Service (8 A.M. to 4:30 P.M. — Eastern and Pacific Times)

Phone: (800) 831-7133

Fax: (800) 284-4151

Web site

visit www.pentairpool.com or www.staritepool.com to find information about Pentair products.

Technical Support

Sanford, North Carolina (8 A.M. to 4:30 P.M. ET)

Phone: (919) 566-8000

Fax: (919) 566-8920

Moorpark, California (8 A.M. to 4:30 P.M. PT)

Phone: (805) 553-5000 (Ext. 5591)

Fax: (805) 553-5515

TABLE OF CONTENTS

Important Warning and Safety Instructions	ii	Full Bag Indicator	5
General Installation Information	ii	Remote Control (830 Model Only)	5
Warranty Information	iii	Control Panel of Remote Control (830 Only)	6
Assembly and Set Up	1	Removing the Cleaner from the Pool	7
Overview	1	Maintenance	8
Power Supply	1	Cleaning the Cartridge	9
Cart Assembly	2	Cleaning the Fan	10
Operation	3	Storing the Cleaner	11
Operating the Cleaner	3	Troubleshooting	12
Float Positions (830 Model Only)	3	Replacement Parts	13
Turning the Cleaner On	4	Prowler 820 Replacement Parts	13
Setting Weekly Timer (830 Model Only)	4	Prowler 830 Replacement Parts	14

© 2012 Pentair Aquatic Systems. All rights reserved.

This document is subject to change without notice.

1620 Hawkins Ave., Sanford, NC 27330 • (919) 566-8000

10951 West Los Angeles Ave., Moorpark, CA 93021 • (805) 553-5000

All Pentair trademarks and logos are owned by Pentair, Inc. Pentair Aquatic Systems™, Kreepy Krauly® and Prowler® are trademarks and/or registered trademarks of Pentair Water Pool and Spa, Inc. and/or its affiliated companies in the United States and/or other countries. Unless expressly noted, names and brands of third parties that may be used in this document are not used to indicate an affiliation or endorsement between the owners of these names and brands and Pentair Water Pool and Spa, Inc. Those names and brands may be the trademarks or registered trademarks of those third parties. Because we are continuously improving our products and services, Pentair reserves the right to change specifications without prior notice. Pentair is an equal opportunity employer.

P/N 370443 Rev. C 12/13/12

IMPORTANT WARNING AND SAFETY INSTRUCTIONS



Important Notice:

Attention Installer: This guide contains important information about the installation, operation and safe use of this product. This information should be given to the owner and/or operator of this equipment after installation of the pool cleaner.

Attention User: This manual contains important information that will help you in operating and maintaining this pool cleaner. Please retain it for future reference. Consult Pentair with any questions regarding this equipment.

WARNING Before installing this product, read and follow all warning notices and instructions which are included. Failure to follow safety warnings and instructions can result in severe injury, death, or property damage. Call (800) 831-7133 for additional free copies of these instructions.

Consumer Information and Safety

The Prowler® 820 and 830 pool cleaners are designed and manufactured to provide many years of safe and reliable service when installed, operated and maintained according to the information in this manual. Throughout the manual, safety warnings and cautions are identified by the “▲” symbol. Be sure to read and comply with all of the warnings and cautions.

WARNING RISK OF ELECTRICAL SHOCK OR ELECTROCUTION.



Connect only to a grounding type receptacle protected by a ground-fault circuit-interrupter (GFCI). Contact a qualified electrician if you cannot verify that the receptacle is protected by a GFCI.

WARNING HAZARDOUS SUCTION.



Do not play with cleaner or hose or apply to body. Can trap and tear hair or body parts. Hose can trip or entangle swimmers which could result in drowning.

WARNING Do not operate the robotic pool cleaner when there are people swimming in the pool. Hose can trip or entangle swimmers which could result in drowning.

WARNING When examining the robotic pool cleaner, disconnect the main power supply.

WARNING Keep the robotic pool cleaner out of reach of children or persons with reduced physical, sensory or mental capabilities, or lack of experience and knowledge, unless they have been given supervision or instruction.

WARNING Only an original power cable must be used, at all times. Replaced by a robotic pool cleaner certified technician, in case of need to avoid hazard.

WARNING To reduce the risk of electrical shock, do not use extension cord to connect unit to electrical supply; provide a properly located outlet.

CAUTION Only a trained operator should operate the robotic pool cleaner.

CAUTION To avoid hand injury, operator should keep hands away from driving belt mechanism.

CAUTION Position the caddy and power supply at least 10 feet (3 m) from the edge of the pool during operation.

CAUTION When lifting the robotic pool cleaner, take care to prevent back injury.

CAUTION Do not bury cord - locate cord to minimize abuse from lawn mowers, hedge trimmers and other equipment.

General Installation Information

FCC Statement

NOTE: This equipment has been tested and found to comply with the limits for a Class B digital device, pursuant to part 15 of the FCC Rules. These limits are designed to provide reasonable protection against harmful interference in a residential installation. This equipment generates uses and can radiate radio frequency energy and, if not installed and used in accordance with the instructions, guarantee that interference will not occur in a particular installation. If this equipment does cause harmful interference to radio or television reception, which can be determined by turning the equipment off and on, the user is encouraged to try to correct interference by one or more following measures:

- Reorient or relocate the receiving antenna.
- Increase the separation between the equipment and the receiver.
- Connect the equipment into an outlet on a circuit different from that to which the receiver is connected.
- Consult the dealer or an experienced radio/TV technician for help.

Changes or modifications to this equipment not expressly approved by the party responsible for compliance (Pentair) could void the user's authority to operate this equipment.

Pre-Installation Check List

Before installing your cleaner, review and understand all warnings and safety information in this guide. Failure to follow these instructions or improper installation of the cleaner can result in damage to the pool finish or the vinyl liner, Pentair Aquatic Systems disclaims any liability for repairs or replacement to any of these structures or components of the customer's pool.

Before installing the cleaner in a vinyl liner pool:

Check liner closely for signs of deterioration or damage from age, chemicals, pool wall damage, etc. If any damage is found, have a qualified pool professional make all the necessary repairs. Also, if there are stones, roots, etc., under the liner, remove them before installing the cleaner.

Before installing the cleaner in a gunite pool or a pool that is partially or completely tiled:

Repair loose tiles and tighten any loose light rings.

Before installing the cleaner, clean your filter system

Make sure you have cleaned the filter, including backwashing, rinsing, and emptying all baskets. A clean system is necessary for proper cleaner operation and coverage.

Before installing the cleaner, understand cleaner coverage:

The cleaner is designed to rid your pool of debris in approximately 4-6 hours. Less time could be needed, depending on the pool size. The cleaner was not designed to automatically clean steps or swimouts or to work under a solar cover. It was also not designed to do initial cleanup for a new pool or when opening your pool for the season.

AFTER installing the cleaner, make sure the cleaner is operating correctly :

The cleaner may need some minor adjustments to make sure it is operating properly so there is no damage to the pool finish. Certain vinyl liner patterns are particularly susceptible to surface wear, pattern removal, ink rubbing off of, or serious scratches to the pattern caused by objects coming into contact with the vinyl surface, including automatic pool cleaners. Pentair Aquatic Systems is not responsible for any pattern removal, abrasions or markings on vinyl liners.

WARRANTY INFORMATION

Limited Warranty Terms & Conditions

Before installing your cleaner, review and understand all warnings, safety and warranty information in this guide. Failure to follow these instructions or improper installation of the cleaner can result in damage to the pool finish or the vinyl liner, Pentair Aquatic Systems disclaims any liability for repairs or replacement to any of these structures or components of the customer's pool.

The Cleaner manufacturer, Pentair Aquatic Systems ("Manufacturer"), hereby provides the following limited warranty to the purchaser ("Customer"): WHICH IS SUBJECT ONLY TO THE FOLLOWING CONDITIONS AND EXCLUSIONS:

This limited warranty does not include replacement of parts which become discolored due to exposure to sunlight or chemicals, or parts which, even if worn, do not affect performance of the cleaner. Nicks, scratches, fading, discoloration, etc. are cosmetic conditions that do not affect mechanical performance. **Both Manufacturer and dealer of Pentair Aquatic Systems reserve the right to deny any and all warranty claims made for worn parts if the wear does not negatively affect mechanical performance of the cleaner.**

The Cleaner is designed to function in a properly designed, constructed and maintained pool. This limited warranty does not extend in the circumstances where the pool's design, construction or maintenance is defective, substandard or inappropriate for the Cleaner's operation.

Deterioration, discoloration or brittleness of any pool finish can be caused over time separately by, or in combination with, age, an imbalance in water chemistry, improper installation, and other factors. Customer hereby disclaims any and all claims, and releases Manufacturer from any and all claims for damages to any pool plaster or vinyl liner in Customer's pool by reason of the use and/or operation of the Cleaner.

Under no circumstances shall Manufacturer be liable for any loss or damage, whether direct, consequential or incidental, arising out of the use or inability to use the Cleaner or the Hose in Customer's pool.

This limited warranty does not apply to any injury, loss, damage, defect, or malfunction of the Cleaner or failure to function resulting from any failure to operate or maintain the Cleaner in accordance with the directions contained in the Installation and Operation Manual or operating instructions provided by Pentair Aquatic Systems or any injury, loss, damage, defect, or malfunction, or failure to function resulting from any accident, acts of God, alterations in the Cleaner by anyone other than Manufacturer; or misuse, unreasonable use, tampering, abuse, acts, omissions, failure or negligence by anyone other than Manufacturer including but not limited to such damages or injuries to parts resulting from improper installation, or damage to pump parts resulting from running the pump dry (e.g., interruption in or inadequate supply of water to internal pump parts due to loss of prime, or obstruction in lines or otherwise); or damage, defect or malfunction resulting from defects in, failure or malfunction of, or negligence, abuse, or misuse with respect to equipment other than the Cleaner; or any damage or loss of any nature whatsoever and personal injury caused due to the presence of a foreign object in or about the pool.

Disclaimer of Liability About your Pool and Prowler® 820 and 830

There are a multitude of factors that contribute to the life of your pool. The Prowler 820 and 830 robotic pool cleaner are very passive products that will have no impact on pool life.

Please be aware that over time, deterioration, discoloration and brittleness of any pool finish can be caused separately by, or in combination with, age, an imbalance in pool water chemistry, improper installation and other factors. Robotic pool cleaners, such as the Prowler 820 and 830, will not remove or cause wear on "good" pool plaster. In fact, the opposite is true—pool plaster will eventually cause wear on the cleaner.

The same situation holds true for vinyl-lined in-ground swimming pools, because vinyl liners are also affected by the environment and factors such as pool water chemistry, sunlight and the pool's surroundings. Therefore over time, vinyl can become brittle and weak. In addition, vinyl-lined pools are affected by the workmanship, composition and installation of the liner and the workmanship and quality of construction of the supporting walls and pool base. These are all factors which can contribute to liner failure. The existence of any of these type of conditions in your pool is not caused by the use or operation of the Prowler 820 and 830. The manufacturer disclaims any liability for repairs or replacement to any of these structures or components of the customer's pool.

The pool owner must assume all responsibility for the condition and maintenance of the pool's surface, water and deck.

SAVE THESE INSTRUCTIONS

ASSEMBLY AND SET UP

Overview

Prowler® 820 and 830 Robotic Cleaners are designed to scrub, vacuum, and filter (including the waterline) your inground pool. Before operating this product, be sure to read and follow all warning and safety instructions on pages ii-iii.

Cleaners Include:

- Cleaner with 55 ft. floating cable
- Caddy and Power Supply
- Weekly timer with full bag indicator (830 model)
- Cycle selector remote control (830 model)

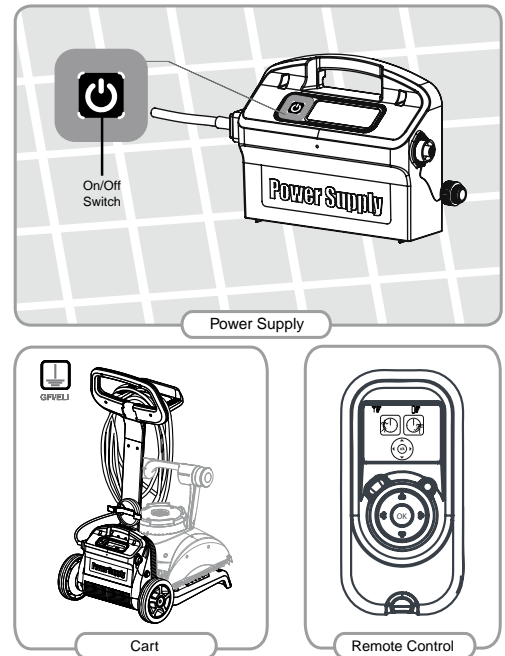

Power Supply

- Connect only to a grounding type receptacle protected by a ground-fault circuit-interrupter (GFCI).
- Do not use an extension cord to connect the unit to the electrical supply. Provide a properly located outlet.
- Position the caddy and the power supply at least 10 feet (3 m) from the edge of the pool during operation.
- Keep power supply out of standing water
- Use only the original power supply - Digital, "switch mode", 100-250 AC.

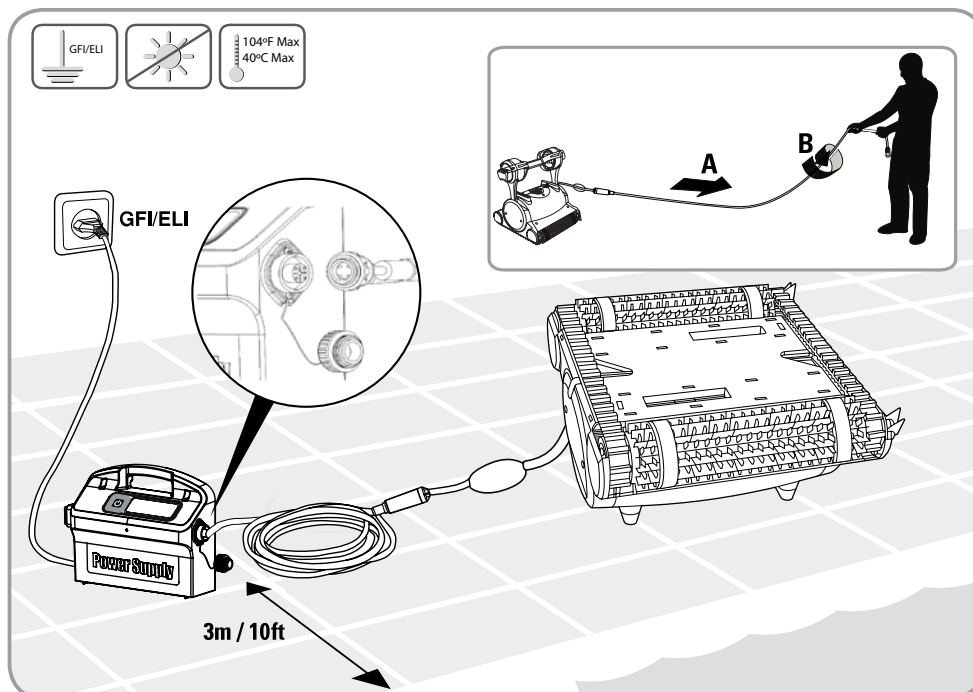

Caddy Assembly

1 **2** **3a** **3b** **4a** **4b** **4c** **5** **6** **7** **8** **9** **10**

* For Liberty Models

* For Remote Control Models

8mm (5/16")

click!

click!

OPERATION

Operating the Cleaner



Do not switch the pool cleaner to "ON" if it is not fully immersed in water. Operating the cleaner out of water will immediately cause severe damage and will result in loss of warranty. Do not leave the cleaner in the pool all the time. Always remember to turn the power supply "OFF" and unplug it from the power outlet before removing the cleaner from the pool.

1. Be sure the power supply is positioned at least 10 feet (3 m) from the pool.
2. Place the cleaner in the water as shown. Shake the cleaner from side to side or turn upside down to release trapped air.
3. Press the ON/OFF button to start the cleaner. The cleaner is now ready to begin its cleaning cycle.
4. The cleaner will automatically shut off at the end of its cleaning cycle.

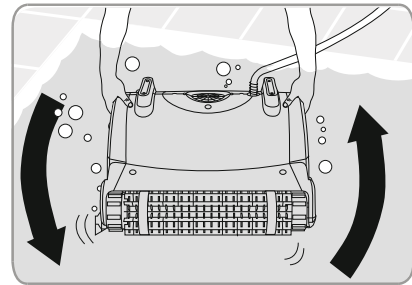
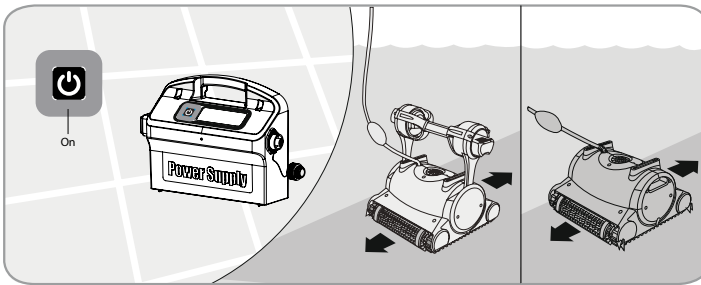
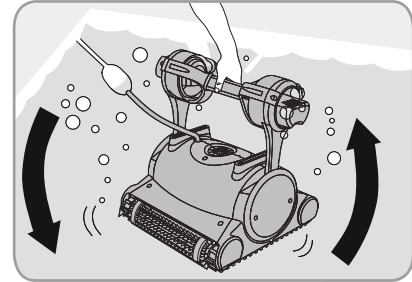

Float Positions for Brushes (830 Model Only)

Place the cable at the right side in front of the handle. Pull out only one float. This helps the cleaner turn in the pool.

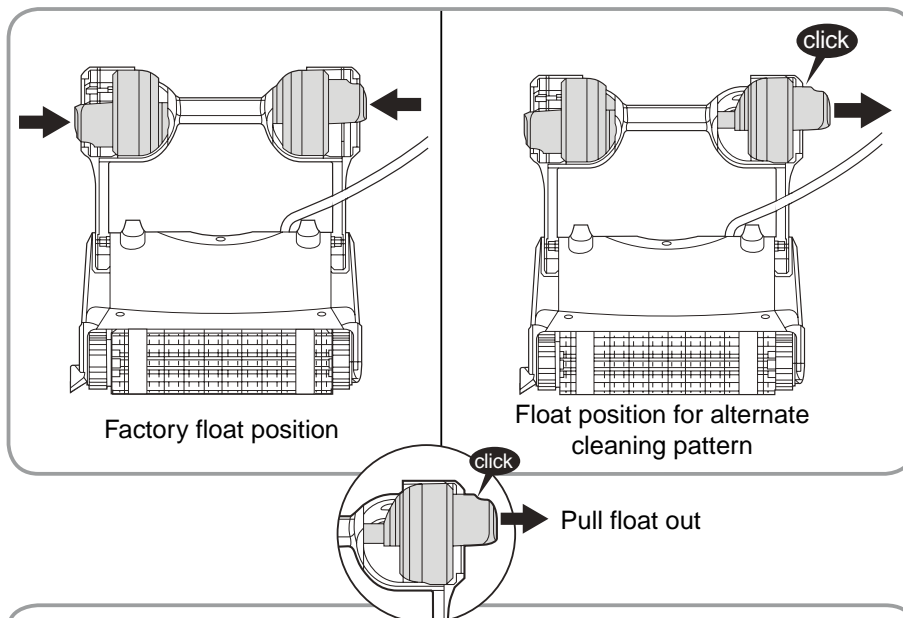

CHLORINE
max 4 ppm

PH
7 - 7.8

34°C 93°F
6°C 43°F

NaCl
max
5000 ppm

Soak brush before use.

If brushes are dry, soak in water until soft. The cleaner may not grip the bottom and walls of the pool as effectively if the brush is dry.

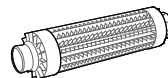

Digital Switch Mode Power Supply Weekly Timer and Full Filter Bag Indicator

The power supply has a timer control that allows you to set an automatic cleaning schedule each week. Be sure the cleaner is fully immersed in water before turning on the power.

Turning the Cleaner ON

1. Plug the floating cable from the cleaner into the power supply unit.
2. Plug the electrical cable from the power supply unit into a house receptacle.
3. Assemble the power supply onto the cart.
4. Press the ON/OFF switch on the power supply unit. The cleaner will now start to work.

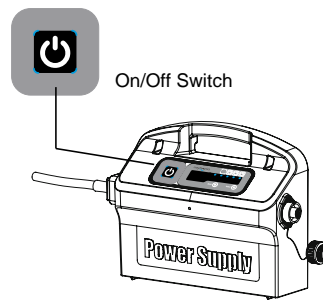
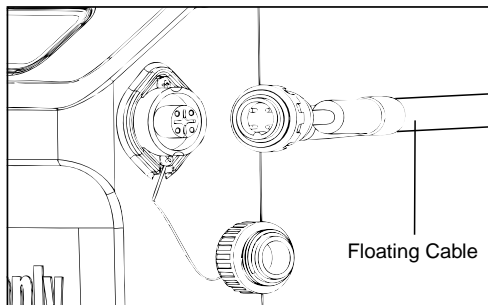

- Input - 100-250 AC Volts
- 50-60 Hertz
- 180 Watt
- Output - 30 VDC
- IP 54

Setting the Weekly Timer (830 Model Only)

When the power supply is switched on, the 3 LEDs will blink for 5 seconds. At this time by pressing the SELECT button, you may choose a pool cleaning schedule for the coming week.

Note: The cleaner will always begin to work upon set-up.

LED 1 - The cleaner will automatically work every day for a full cycle = 7 times per week.

LED 2 - The cleaner will automatically work every other day for a full cycle = 3 times per week.

LED 3 - The cleaner will automatically work every 3 days = 2 times a week.

If you do not press any of the buttons within the first 5 seconds after the power has been switched on, the cleaner will default to running one cycle only.

While the cleaner is working in weekly timer mode, the LED will blink constantly between cycles. At the end of the week the power supply automatically shuts off.

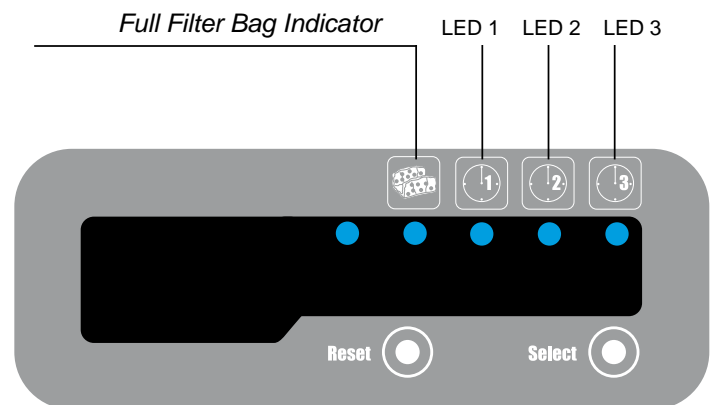

- LED 1** - 7x per week - every day
- LED 2** - 3x per week - every other day
- LED 3** - 2x per week - every 3 days

Digital Switch Mode Power Supply

Weekly Timer and Full Filter Bag Indicator

Full Filter Bag Indicator (820 and 830 Models)

The power supply is equipped with a filter bag status indicator. The red LED indicates 2 filter conditions:

LED Blinking - The filter is partially blocked.

LED Lit - The filter is blocked and must be emptied and cleaned.

If the LED does not shut off after cleaning the filter, press RESET while the cleaner is on.

Remote Control (830 Model Only)

The Remote Control Unit (RCU) offers two operation modes - Automatic mode and Manual direction mode.

- In **Automatic cleaning mode**, the fast or regular cleaning cycle can be selected.
- In **Manual direction mode**, the pool cleaner direction can be controlled manually.

Radio Reception Meter

If no black lines show, you should move closer to the power supply unit

Regular Cleaning Cycle

Manual/Automatic Mode Select Button

Battery level meter -
When the icon flashes, change the batteries

Fast Cleaning Cycle

Manual Control Indicator

ON/OFF Button

Set/OK Button

Direction Control Arrows

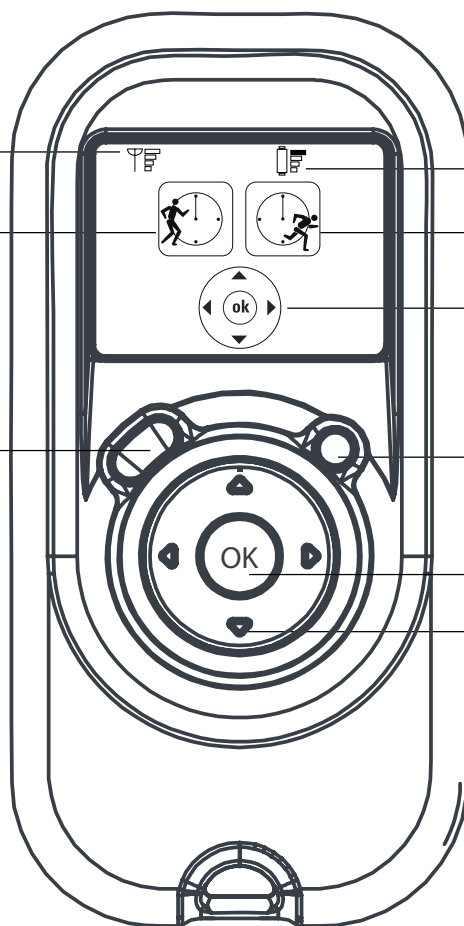

Control Panel of the Remote Control

Manually controlling the direction of the Pool Cleaner

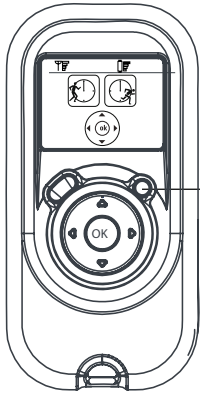

ON/OFF
button

1. Press the ON/OFF button once -
The remote control unit will start up
in Manual direction control mode.

2. To manually control the direction of
the pool cleaner, use the Direction
control arrows (see right).

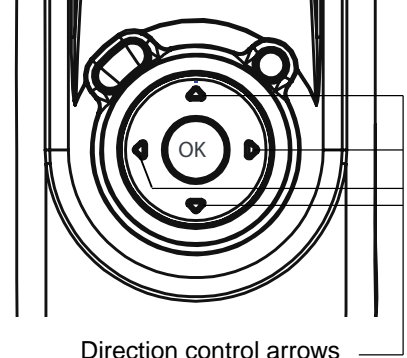

Direction control arrows

Exiting Manual Direction Control Mode and set the Automatic Mode

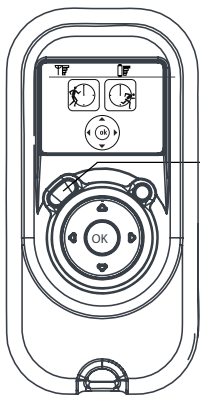

Manual/Automatic
select button

To exit the Manual direction control
mode, press the Manual/Automatic
Selection button *only once*.

The Digital screen will light up and
the two (regular/fast) icons will appear.

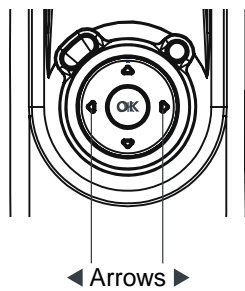
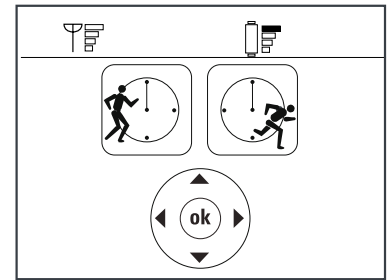

Arrows

To choose regular or fast cleaning
cycle use the right or left arrows.

When you reach the required
function press the Set/OK button.

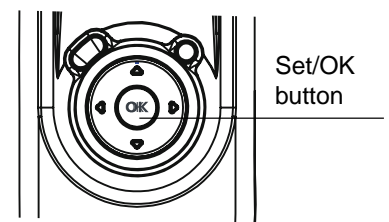

Set/OK
button

Notes:

- If the fast cleaning cycle is chosen, the pool cleaner will not climb the walls.
- After 2 minutes, if no button is pressed the remote control unit (power supply) will shut down and the cleaner will resume the scheduled cleaning cycle.

Removing the Cleaner

The cleaner will shut off automatically at the end of a cleaning cycle. Follow the steps below to remove the cleaner from the pool.

- Slowly and gently pull on the cord, up to about 4 in. (10 cm) from the cord base, in order to get the cleaner close to you.
- Use both hands to remove the cleaner from the pool.
- Avoid pulling the cleaner out of the pool by the cord only.

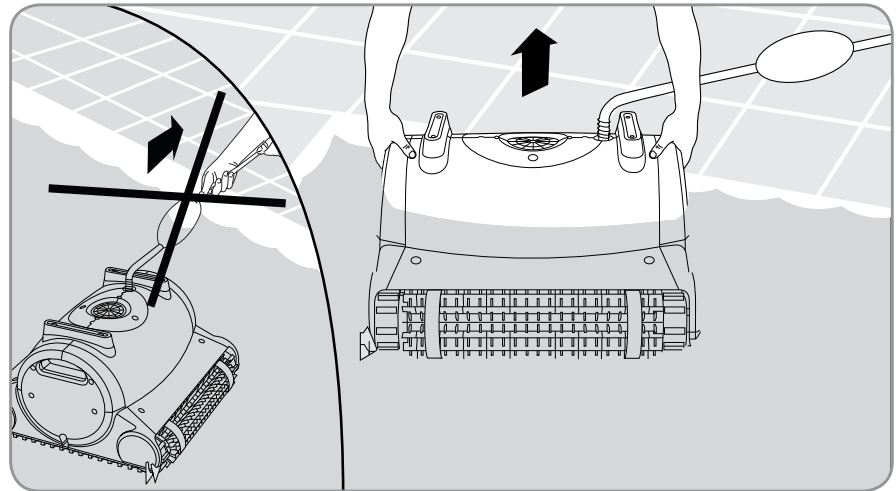
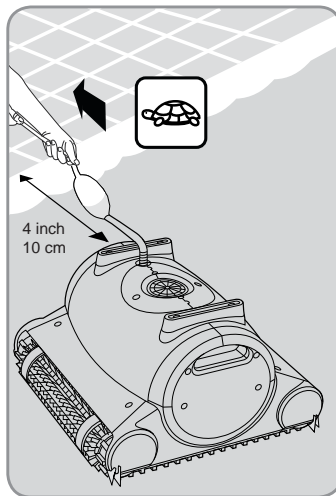

- Disconnect the power supply cable from the electrical outlet. Disconnect the cable from the power supply.
- Turn cleaner on its side to drain water after use.
- Store the cleaner on the caddy with the cable coiled when not in use.

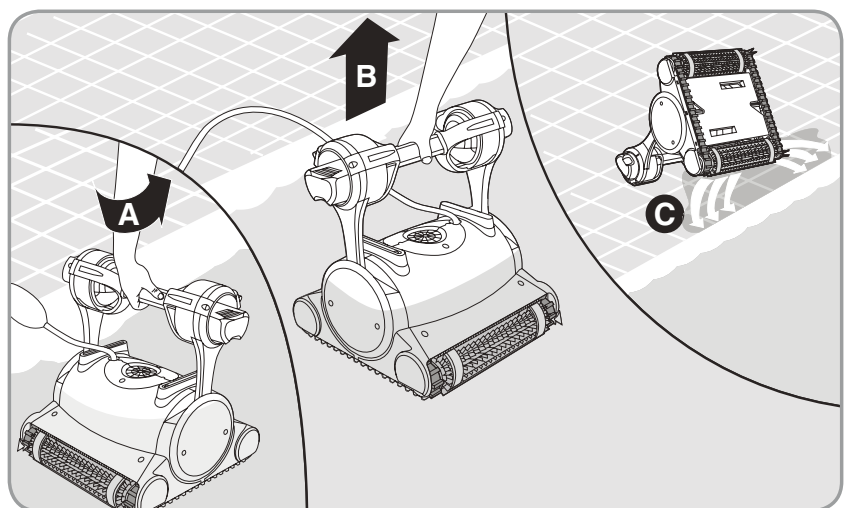
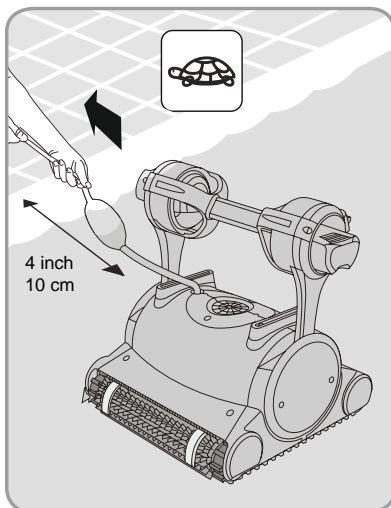

MAINTENANCE

Cleaning the Cartridge

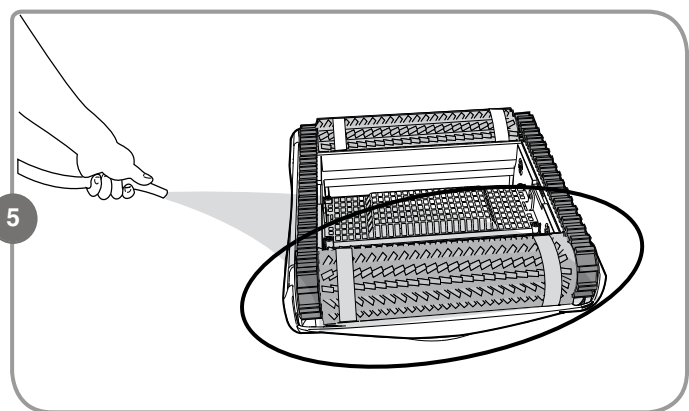
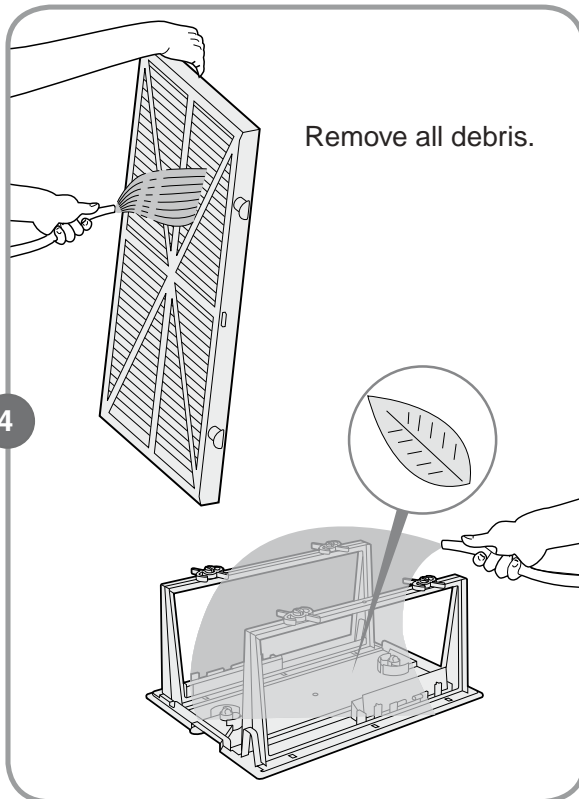
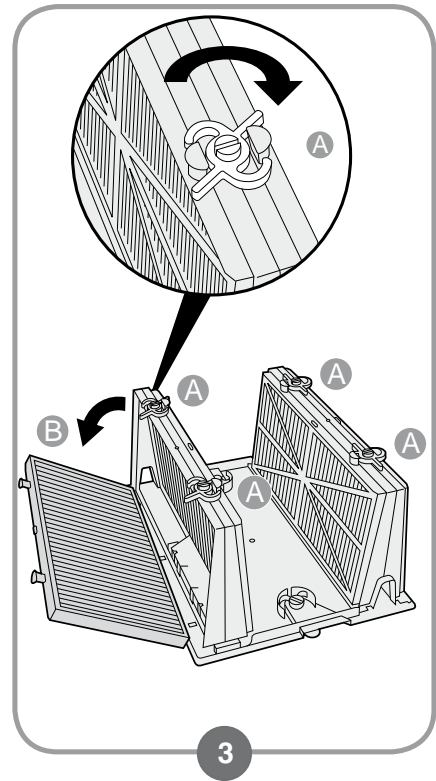
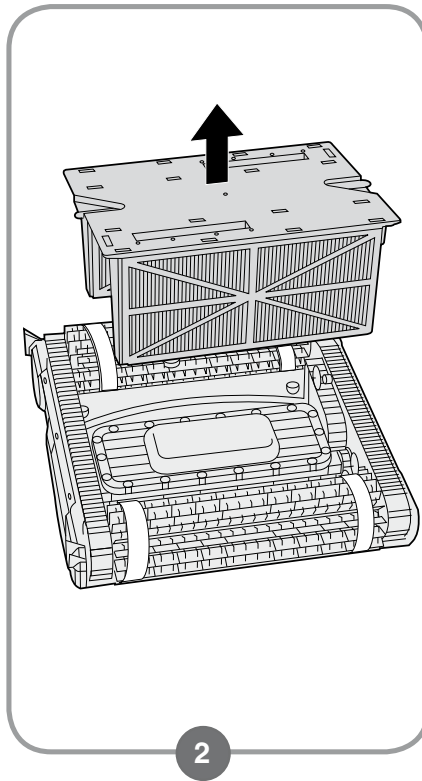
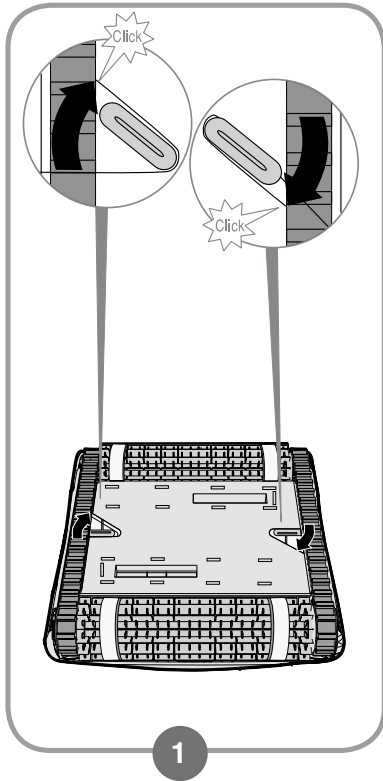

- It is recommended to wash the cartridge after every cycle.
- Too much debris in the filter can restrict the suction power of the cleaner.

Cleaning the Cartridge

Dual-level filtration system

- “Ultra-fine” filters for day-to-day use. Factory default.
- Spring “net” filters for dirty pools with large debris such as leaves etc., useful for beginning of season, are included.
- It is recommended to wash the cartridge after every cycle.

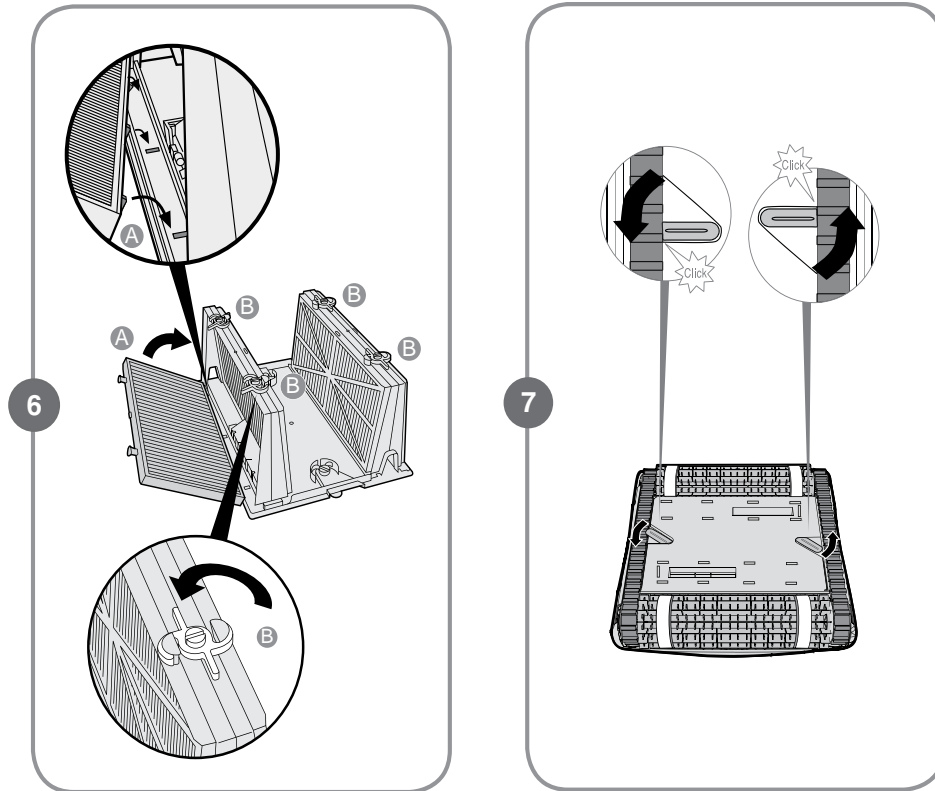

Cleaning the Fan



WARNING

Always disconnect power to the cleaner before servicing, disassembly or reassembly. Failure to do so could result in death or serious injury to servicemen, pool users or others due to electrical shock. Read all servicing instructions before servicing the cleaner.

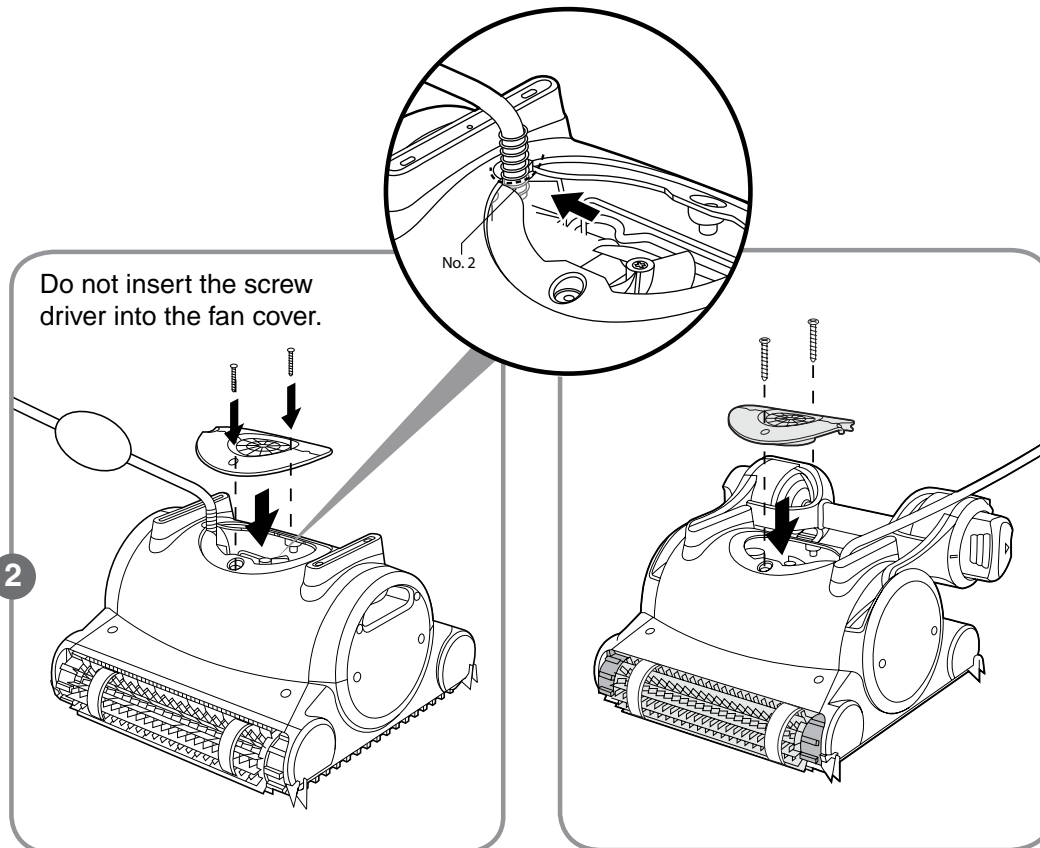
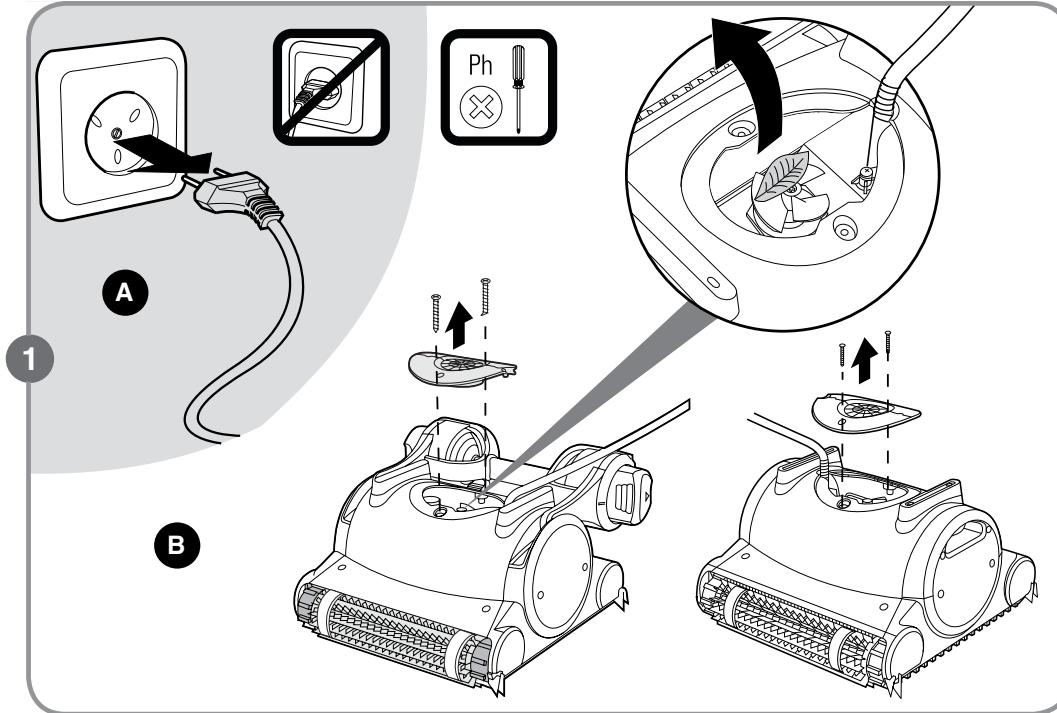

Storing the Cleaner

Be sure to disconnect the power supply after use. Use the caddy to store the power supply, cable, and cleaner. Check the cable periodically for external damage.

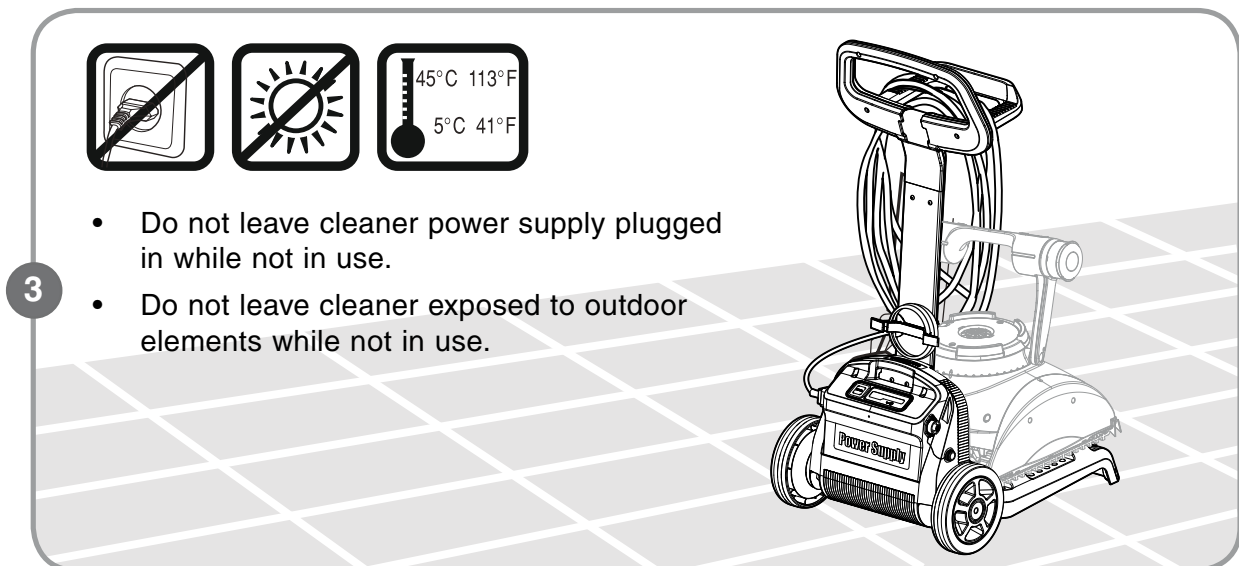
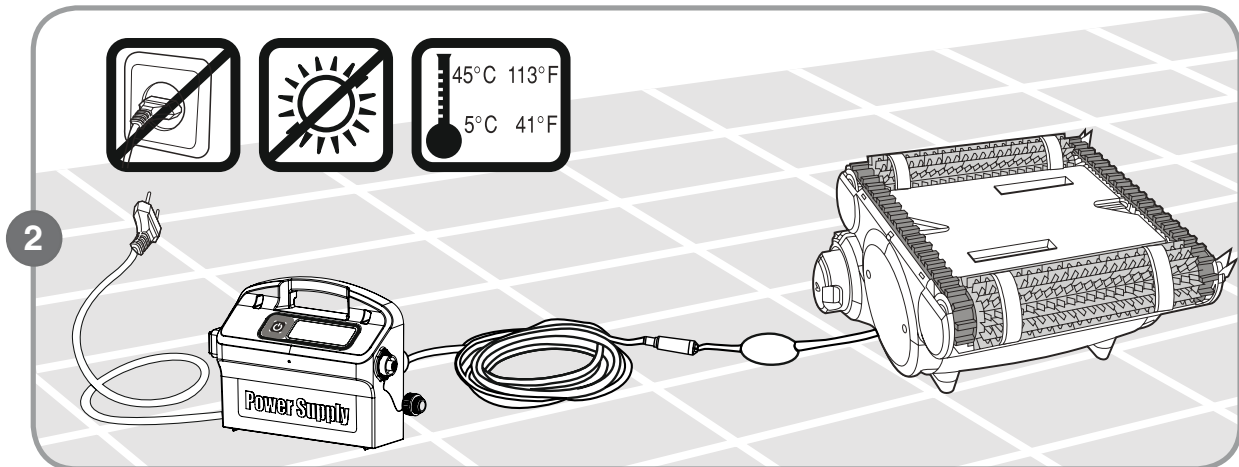
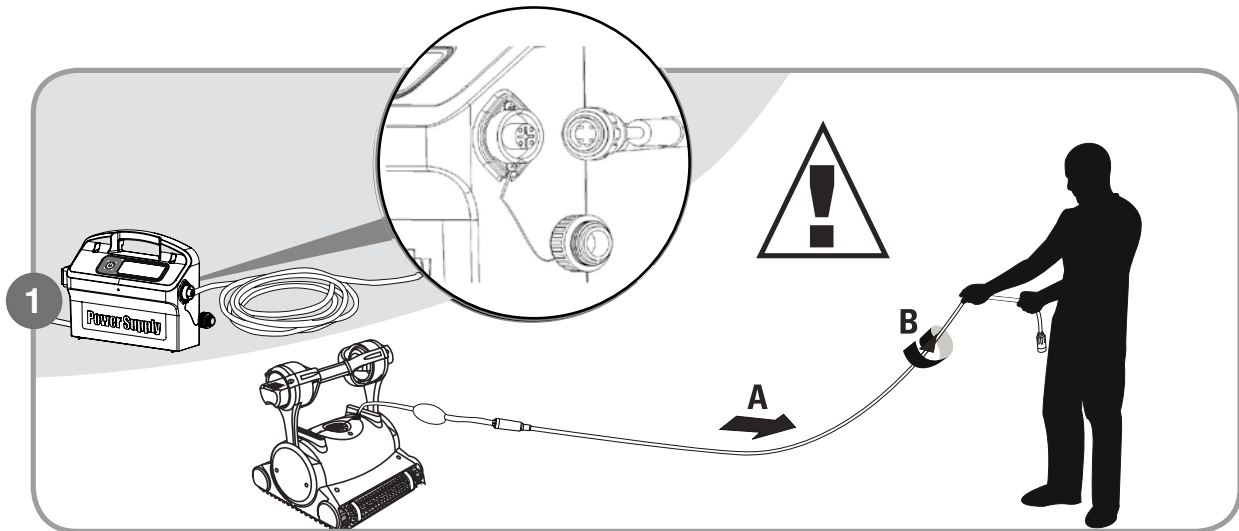

TROUBLESHOOTING

Problem	Possible Cause	Corrective Action
Cable twisting or cable coils up.	Obstruction in pool Pool shape Gets stuck on main drain cover Excess cable in the pool	Remove obstruction in pool. Contact your dealer; install cable with swivel. Turn off filter and install main drain cover ring Straighten cable and lay in sun periodically. Remove excess cable from pool.
Cleaner is moving in circles	Dirt stuck in moving parts Tracks worn due to extended use Power supply positioned incorrectly Wrong mounting of bottom lid Algae in pool.	Remove dirt from moving parts. Contact your dealer. Replace tracks. Place power supply in a position so that the cleaner can reach all walls. Lock bottom lid in the right position. Correct pool and water conditions.
Cleaner does not reach all areas of the pool	Power supply positioned incorrectly Cleaner does not climb walls Algae on pool walls and floor Pool filter and pump is o Cleaner is not turning 90° on pool floor or turning more than 90°	Place power supply in a position so that the cleaner can reach all walls. Check reasons for not climbing walls below. Brush pool walls and floor . Turn off pool filter and pump and run another cleaning cycle. Improve floor movement by shifting handle float position.
Cleaner does not climb walls	Cleaner is too heavy Algae on walls Water temperature too low and/or too high Brushes are worn Slippery ceramic wall tiles Debris caught around impeller Cleaner is too light from trapped air Unsuitable pH level	Clean and wash cartridge. Brush walls. Ideal water temperature between 54-90° F (12-32° C) Replace brushes - contact your dealer. Consult with your dealer about special brushes. Remove impeller tube. Clean impeller. Turn cleaner upside down under water to remove trapped air. Check pH level - should be between 7.4 - 7.8; minimum level of 7.2.
Motor not working	Impeller blocked Drive system blocked Electrical problem - motor unit, floating cable, or power supply	Remove impeller tube. Clean impeller. Clean tracks and wheels. Consult with your dealer or service center.
Cleaner will not sink	Air caught in trapped in cleaner Combined brush is dry	Turn cleaner upside down under water to remove trapped air. Wash the cartridge. Remove calcium deposits or other chemical sediments. Open two inlet flaps in the bottom lid to remove dirt and/or trapped air. Soak brushes in water.
Power supply or power supply switch light is not working	Not plugged in properly or main socket is damaged	Reconnect and check main power supply.
Operator neglect	Operator has damaged cleaner Operator has pulled on the cable Operator does not maintain cleaner Cleaner was powered on while not in water Power supply got wet Normal wear from extended use.	Replace broken/damaged parts. Repair loose electrical wiring. Purchase or clean cartridge and cleaner. Seals may be damaged. Replace motor unit. Needs to be repaired or replaced. Routine servicing needed.

REPLACEMENT PARTS

Prowler® 820 Illustrated Parts List

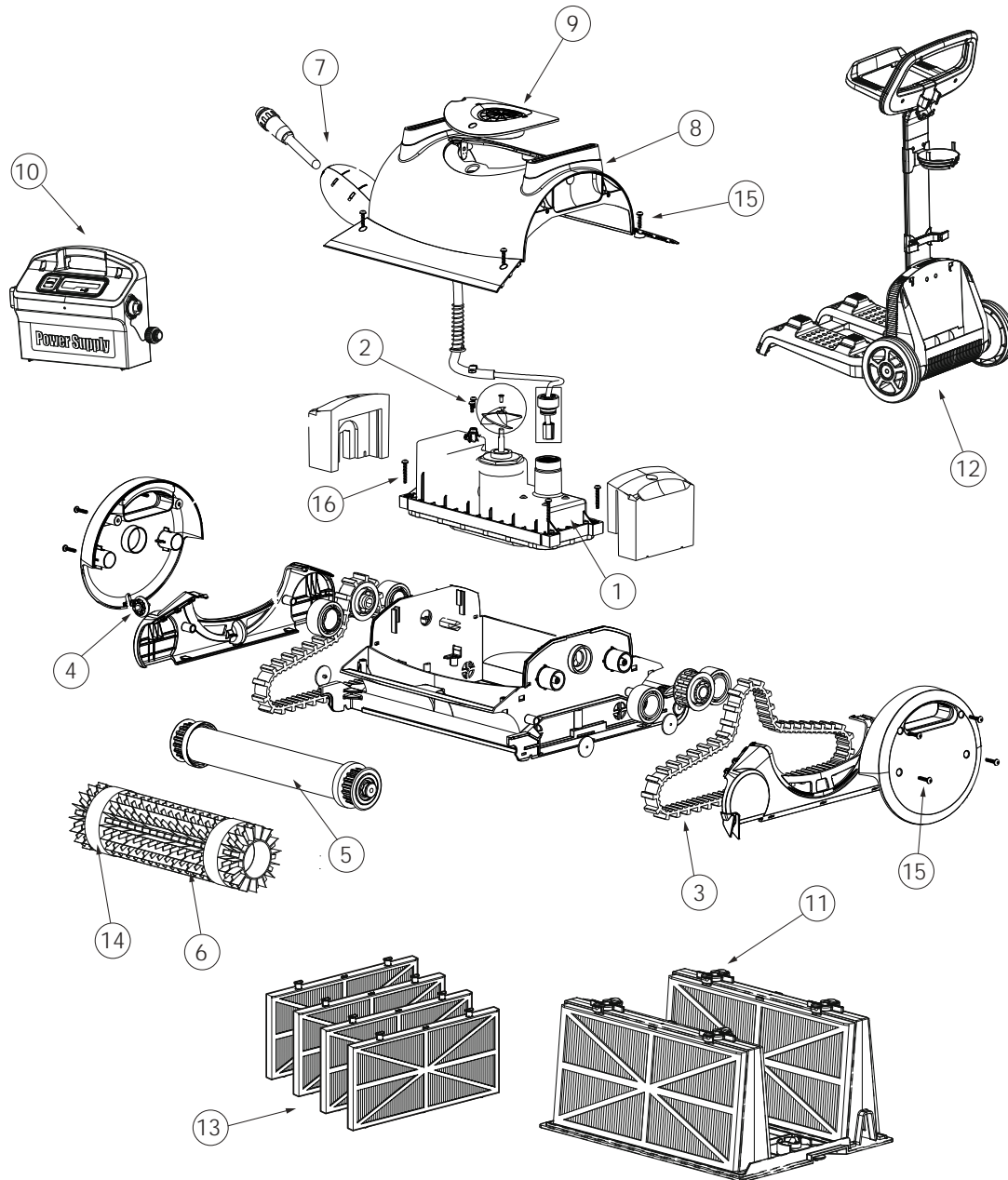

ITEM NO.	P/N	DESCRIPTION	ITEM NO.	P/N	DESCRIPTION
1	360132	Prowler 820 motor	9	360139	Prowler Impeller Cover
2	360131	Prowler Impeller	10	360125	Prowler 820 Power Supply
3	360133	Prowler Timing Track	11	360140	Cartridge Assembly
4	360134	Prowler Side Wheel	12	360141	Caddy
5	360135	Prowler Wheel Tube	13	360123	Spring Filter
6	360136	Prowler Brush	14	360142	Climbing Ring
7	360137	Prowler Cable	15	360143	Small Screw
8	360138	Prowler 820 Case	16	360144	Large Screw

Prowler® 830 Illustrated Parts List

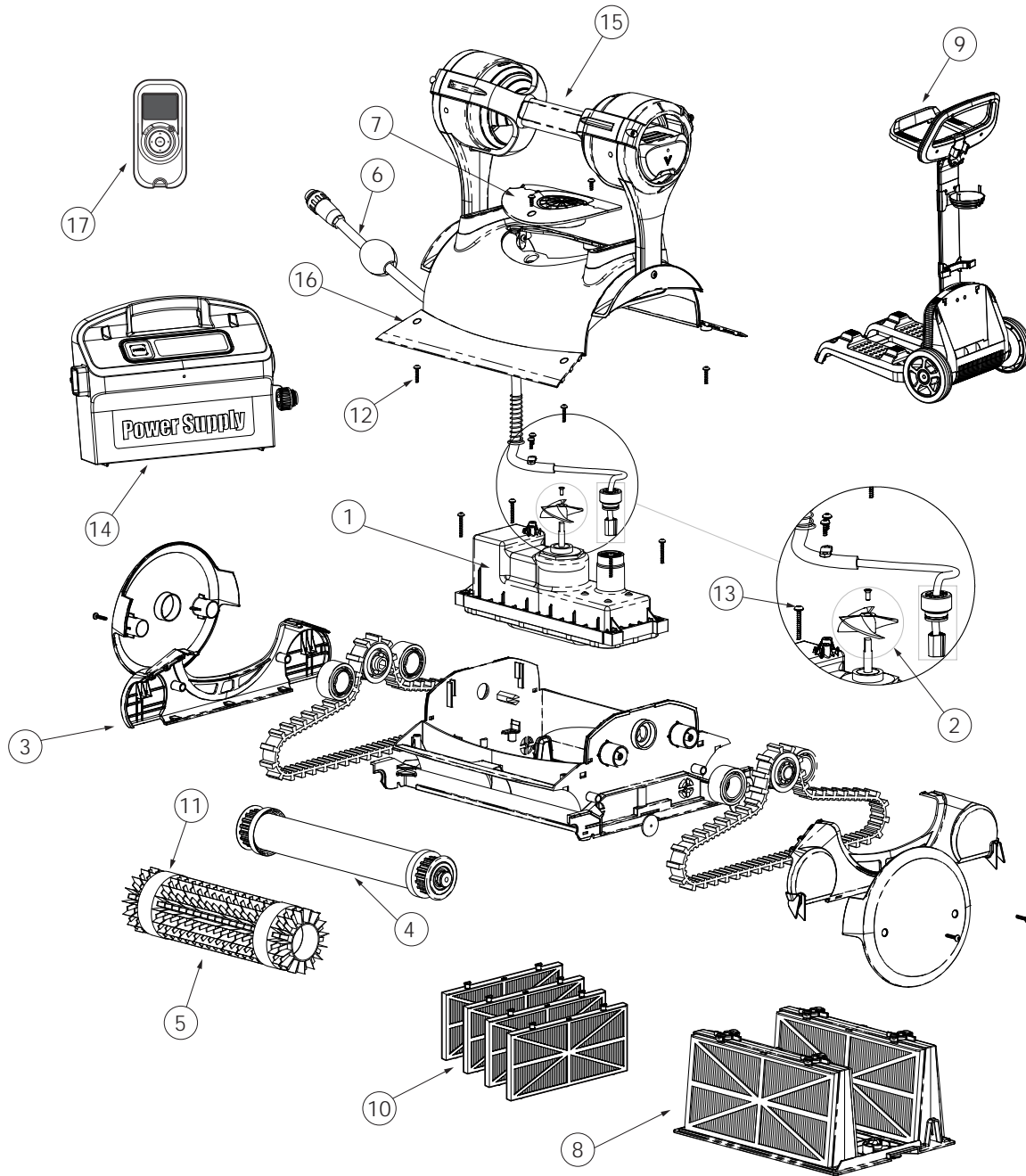

ITEM NO.	P/N	DESCRIPTION	ITEM NO.	P/N	DESCRIPTION
1	360147	Prowler 830 Motor	10	360123	Spring Filter
2	360131	Prowler Impeller	11	360142	Climbing Ring
3	360133	Prowler Timing Track	12	360143	Small Screw
4	360135	Prowler Wheel Tube	13	360144	Large Screw
5	360136	Prowler Brush	14	360126	Prowler 830 Power Supply
6	360137	Prowler Cable	15	360145	Prowler 830 Handle
7	360139	Prowler Impeller Cover	16	360146	Prowler 830 Case
8	360140	Cartridge Assembly	17	360149	Prowler 830 Remote
9	360141	Caddy/Cart			



1620 HAWKINS AVE., SANFORD, NC 27330 • (919) 566-8000
10951 WEST LOS ANGELES AVE., MOORPARK, CA 93021 • (805) 553-5000
WWW.PENTAIRPOOL.COM

© 2012 Pentair Aquatic Systems. All rights reserved. This document is subject to change without notice.