

SHELL AND TUBE HEAT EXCHANGERS

1080 SERIES

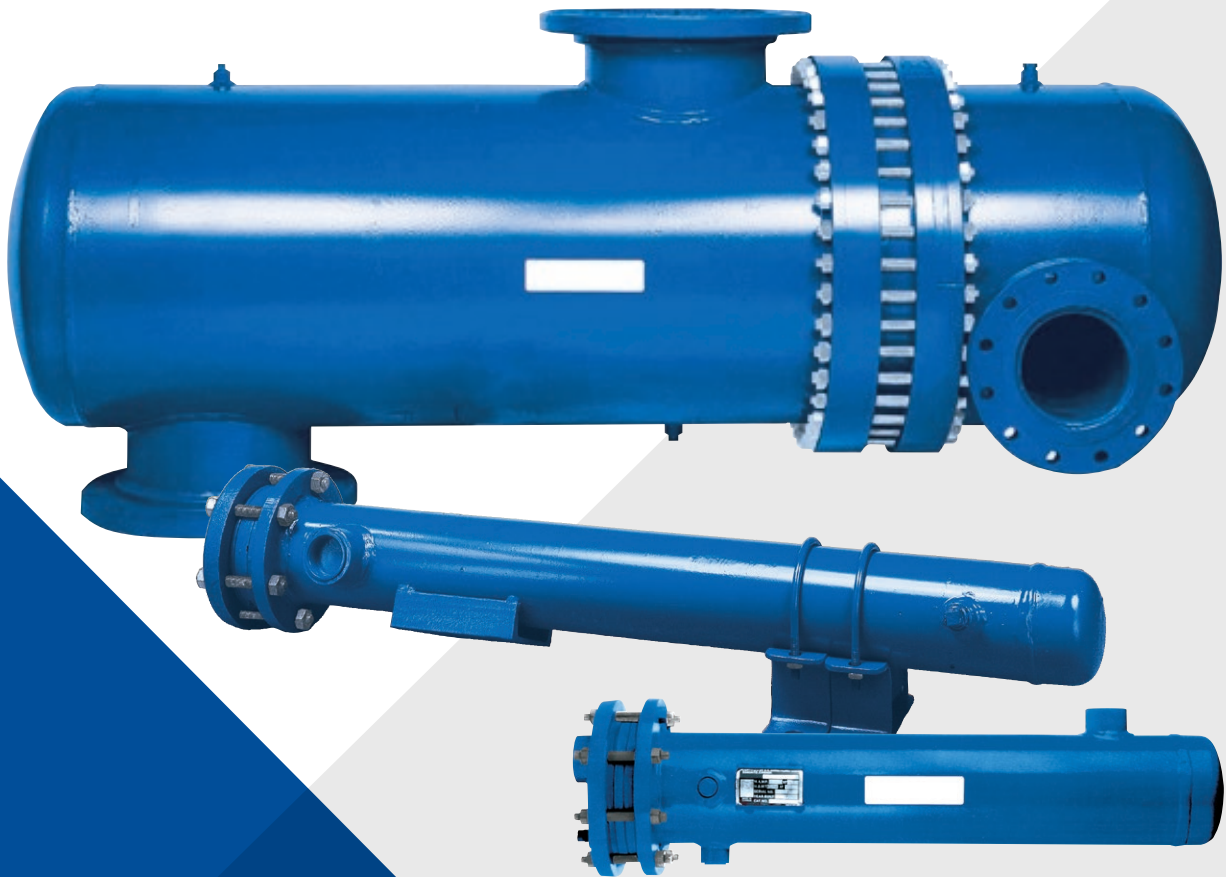

AURORA 1080 SERIES SHELL AND TUBE HEAT EXCHANGERS

THE AURORA FAMILY OF HEAT TRANSFER PRODUCTS IS AIMED AT PROVIDING COMMERCIAL AND INDUSTRIAL USERS WITH A PROVEN RANGE OF HEAT EXCHANGER SOLUTIONS.

THE AURORA RANGE INCLUDES

- ◆ Standard or custom configurations
- ◆ Suitable for water or steam applications
- ◆ Single or double-wall tubing

Aurora's versatile heat exchangers provide dependable, efficient performance for a broad range of commercial and industrial applications where fluids must be quickly heated or cooled. Products offer industry-wide compatibility and are available in numerous material and working pressures to suit the most demanding requirements. The standard Aurora design meets the requirements of ASME Boiler Code Section VIII, Division 1.

TYPE 1080-ST, 1080-STW AND U-TUBE

Aurora U-Tube heat exchangers are designed for durability and include a removable tube bundle as a standard feature. The U-shaped tube design provides a long service life by eliminating the effects of thermal expansion and contraction. These heat exchangers feature carbon steel components, 0.75" (19 mm) copper tubes, and a rugged cast iron head. Components are also available in a selection of materials for use in specific applications.

TYPE 1080-STX, 1080-STWX DOUBLE-WALL AND U-TUBE

Double-Wall tube (tube-in-tube design) heat exchangers are designed for applications in which it is critical that the system prevents the mixing of internal fluids, i.e. potable water heaters. These units, in the event of a leak, allow the liquid to drain to atmosphere. Made from the same quality components as the 1080-STW Series, the tube bundle from a 1080-STWX Series heat exchanger will fit the shell of an existing 1080-STW heat exchanger.

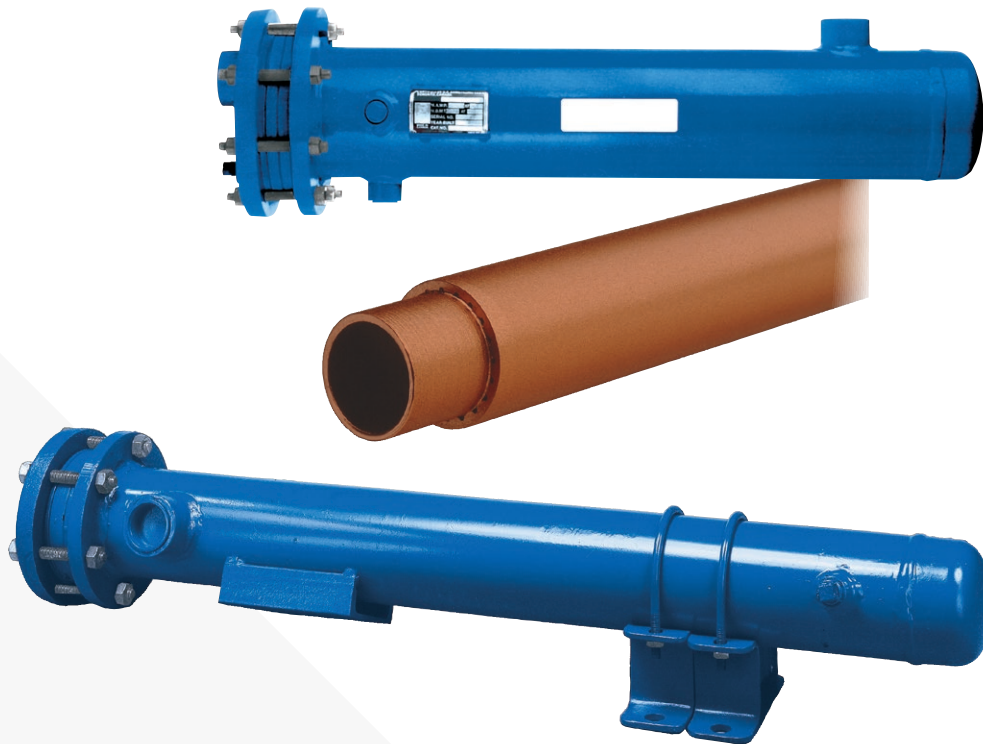

FEATURES, OPTIONS AND DIMENSIONS

FEATURES

- ◆ Carbon steel shell, tubesheet and baffles
- ◆ Heavy-duty U-shaped copper tubes
- ◆ 2 and 4-pass construction
- ◆ Constructed in accordance with ASME Boiler Code Section VIII, Division 1
- ◆ 4" to 30" (102 mm to 762 mm) diameter in varying lengths
- ◆ 1080-ST – water in tubes, steam in shell
- ◆ 1080-STW – steam in tubes, fluid in shell; fluid in tubes and shell
- ◆ Double-wall tubing with double tubesheet
- ◆ High pressure 300 psi and 400 psi (2068 kPa and 2758 kPa) designs
- ◆ Custom sizes and construction
- ◆ Designed to TEMA standards
- ◆ Carbon steel saddles

OPTIONS

- ◆ Carbon steel, brass, stainless steel or 90/10 Cu-Ni tubes
- ◆ Flanged heads with pressure rating of 150 psi (1034 kPa)
- ◆ Bronze or stainless steel heads
- ◆ 316 stainless steel shell
- ◆ Brass and 316 stainless steel tubesheets
- ◆ Brass and 316 stainless steel baffles

DIMENSIONS – INCHES (MM)

1080-ST STANDARD DESIGN			
E	F	G	H
28 (711)	7 (178)	16 (406)	7-1/4 (184)
2	2	2	2
205 (5207)	49 (1245)	144 (3668)	34-1/2 (876)

1080-ST EXTENDED SHELL DESIGN			
J	K	L	M
35-1/2 (902)	7 (178)	16 (406)	7-1/4 (184)
2	2	2	2
226 (5740)	49 (1245)	144 (3668)	34-1/2 (876)

NOTE: All dimensions are approximate.

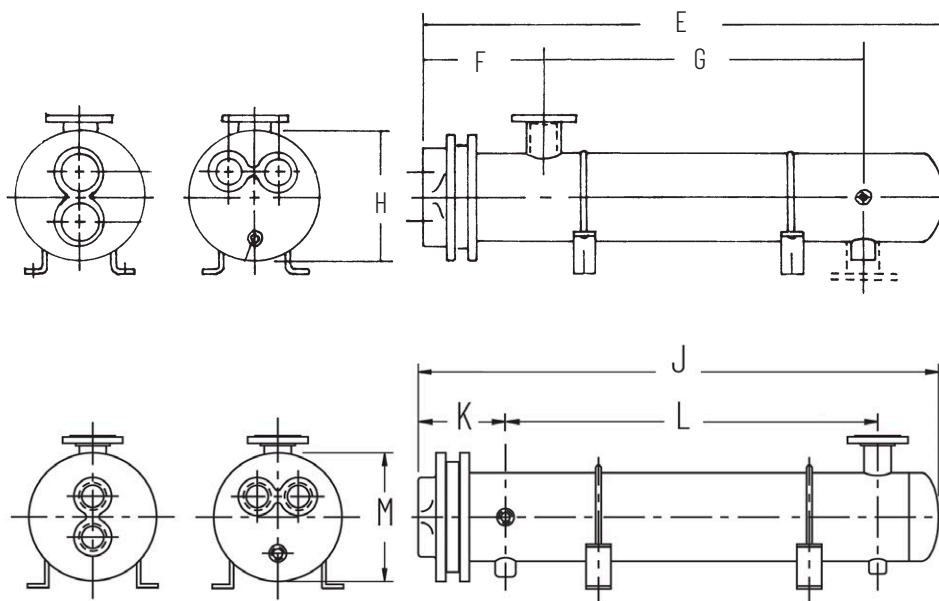

TYPICAL HEATING CIRCUIT

Aurora type 1080-ST and 1080-STW heat exchangers are of shell and tube type, designed for instantaneous heating or cooling of water or other liquids.

A popular application of the 1080-ST exchangers is the heating of water with steam for hot water radiation. Aurora 1080-STW exchangers are used for heating or cooling various fluids, in applications ranging from swimming pools to industrial processes. The construction of these units depends on the fluids used in both the shell and the tubes.

Both types of exchangers are available in either 2 or 4-pass construction. The U-shaped tubes are roller-expanded into a stationary tubesheet; this design allows for the expansion and contraction caused by temperature variations. Units can be connected to any steam boiler or system; however, the capacity of the boiler must be sufficient to handle the load imposed by the heat exchanger. In addition, some method of controlling the flow to the exchanger must be provided and installed according to the manufacturer's directions.

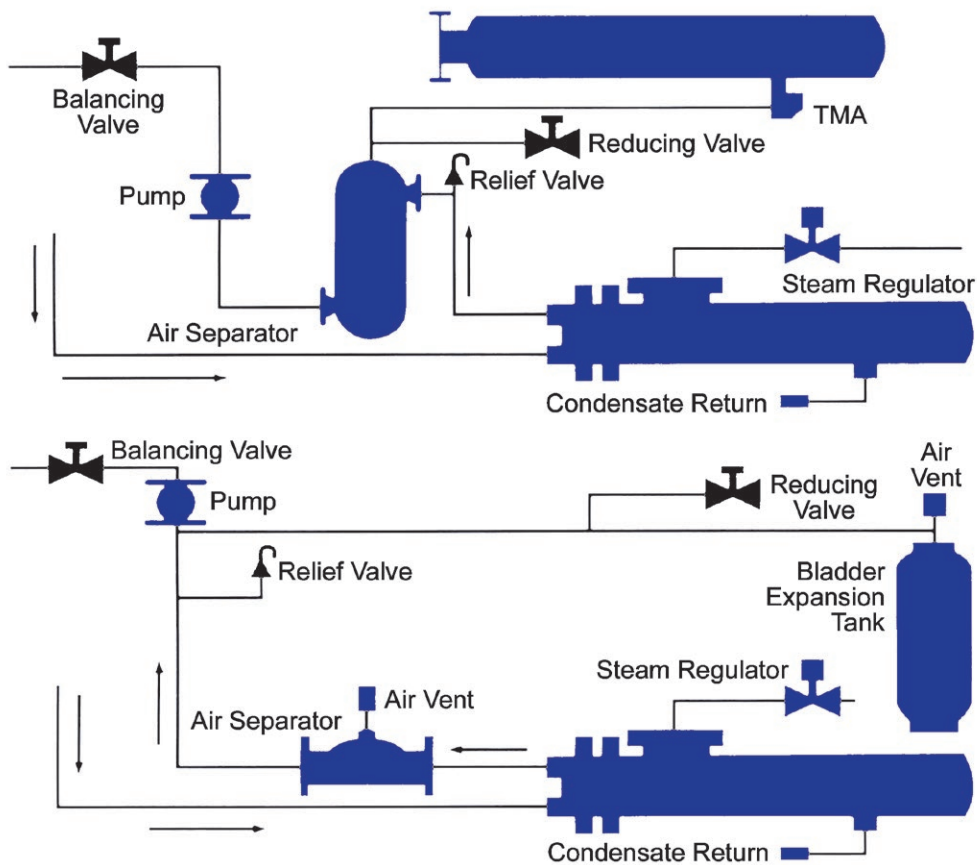

800 Airport Road
North Aurora, IL 60542

3601 Fairbanks Ave.
Kansas City, KS 66106

pentair.com/aurora



WEMA