

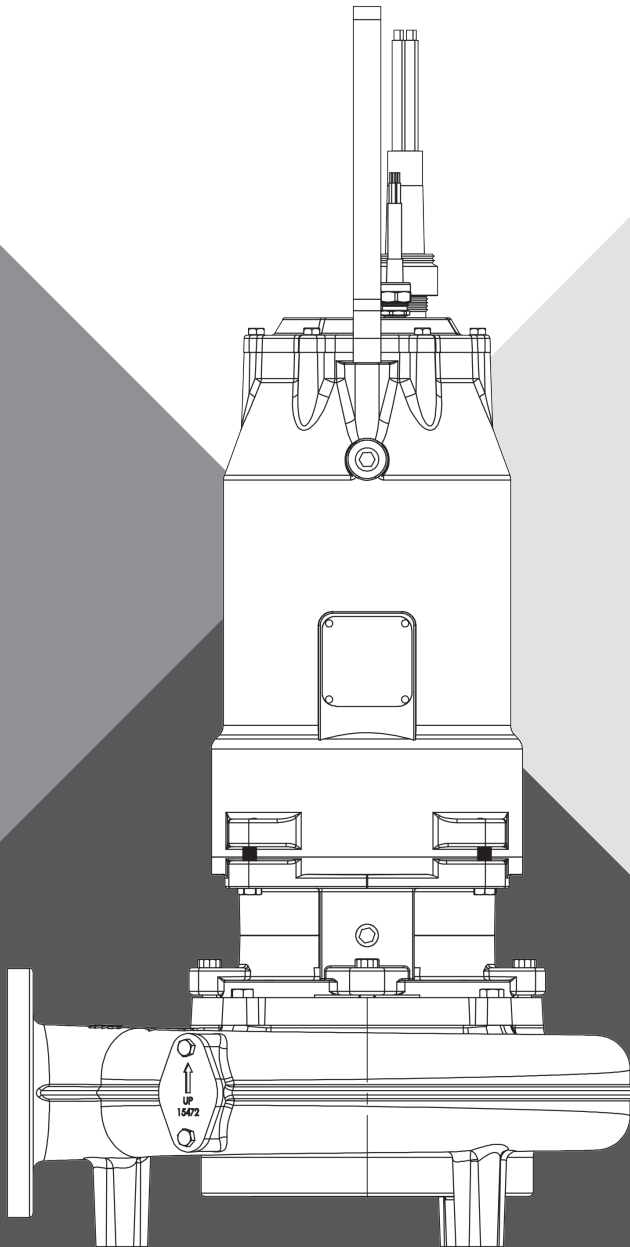

SUBMERSIBLE SOLIDS HANDLING PUMP

HPS4SD(X), HPS4HD(X), HPS6MD(X)

E-03-601 / 056255651 (06-21-24)



INSTALLATION & OPERATION MANUAL

pentair.com/hydromatic

©2024 Pentair. All Rights Reserved.

TABLE OF CONTENTS

SAFETY INFORMATION 3

GENERAL INFORMATION 4

INSTALLATION 5

OPERATION / MAINTENANCE 6

TROUBLESHOOTING 8

PARTS LIST 10

WIRING DIAGRAMS 16

WARRANTY 18

SAFETY INFORMATION

SAFETY SYMBOLS

 This is the safety alert symbol. When you see this symbol on your pump or in this manual, look for one of the following signal words and be alert to the potential for personal injury:

 **DANGER** warns about hazards that will cause serious personal injury, death or major property damage if ignored.

 **WARNING** warns about hazards that can cause serious personal injury, death or major property damage if ignored.



 **CAUTION** warns about hazards that will or can cause minor personal injury or property damage if ignored.



The word **NOTICE**: indicates special instructions that are important but not related to hazards.

CALIFORNIA PROPOSITION 65 WARNING

 **WARNING** This product and related accessories contain chemicals known to the State of California to cause cancer, birth defects or other reproductive harm.

GENERAL SAFETY

- ◆  **CAUTION** Do not touch an operating motor. Modern motors can operate at high temperatures. To avoid burns when servicing pump, allow it to cool for 30 minutes after shutdown before handling.
- ◆ Follow all applicable local and state codes and regulations.
- ◆ Submersible pumps are not approved for and should not be used in swimming pools, recreational water installations, decorative fountains or any installation where human contact with the pump fluid is common. Pump is designed for municipal and commercial wastewater applications.
- ◆ Keep safety labels in good condition, replacing any missing or damaged labels.
- ◆ **DO NOT** run the pump dry. Dry running can overheat the pump, (causing burns to anyone handling it) and will void the warranty.
- ◆ The pump is permanently lubricated. No oiling or greasing is required in normal operation.
- ◆ Periodically inspect pump and system components.
- ◆ Wear safety glasses at all times when working on pumps.
- ◆ Keep work area clean, uncluttered and properly lighted. Store all unused tools and equipment.
- ◆ **DO NOT** use to pump flammable liquids.
- ◆  **DANGER RISK OF FIRE OR EXPLOSION.** Can cause severe personal injury, property damage or death. Do not smoke or use open flames in or around this system.

- ◆  **DANGER CUTTING RISK.** Risk of serious cutting or amputation exists. Use caution as liner plate is extremely sharp. Always keep fingers and hands away from cutting profiles. Disconnect all power sources prior to servicing pump. Pump may start without warning.
- ◆  **DANGER RISK OF ASPHYXIATION.** Installer(s) and/or service personnel must use proper Personal Protective Equipment and follow OSHA 29 CFR 1910.146 or OSHA 29 CFR 1926. Pump may be installed in a location classified as a confined space.
- ◆  **DANGER BIOHAZARD RISK.** Once wastewater source has been connected to system, Biohazard Risk exists. Installer(s) and/or service personnel must use proper personal Protective Equipment and follow handling procedures per OSHA 29 CFR 1910.1030 when handling equipment after wastewater source has been connected to system.
- ◆ **NOTICE:** FM rated models are only to be used in 60hz applications.

ELECTRICAL SAFETY

 **DANGER HAZARDOUS VOLTAGE. CAN SHOCK, BURN, OR KILL.** When installing, operating, or servicing this pump, follow the safety instructions listed below.

- ◆  **DANGER ELECTROCUTION HAZARD:** Must be installed by a qualified professional. Disconnect all electrical power before attempting service.
- ◆ **DO NOT** modify the cord. When wiring to a system control, connect ground lead to the system ground.
- ◆ **DO NOT** splice the electrical power cord.
- ◆ **DO NOT** allow the power leads on the end of the electrical cords to be submerged.
- ◆ **DO NOT** handle or service the pump while it is connected to the power supply.

 **WARNING** A water test must be taken before installation of any water treatment equipment. The water quality can significantly influence the life of your system. You should test for corrosive elements, acidity, total solids and other relevant contaminants, including chlorine and treat your water appropriately to ensure satisfactory performance and prevent premature failure.

GENERAL INFORMATION

This manual contains important safety information regarding the use of this product. This product should only be installed and serviced by a qualified professional. Carefully read and follow all safety instructions in this manual and on the unit itself before installing or operating pump. Keep this manual for future reference.

Reasonable care and safe methods should be practiced. Check local codes and requirements before installation.

UNPACKING PUMP

▲ WARNING **LIFTING HAZARD.** Unassisted lifting of pump can cause injury. Mechanical assistance required.

DO NOT life pump by power cord.

When unpacking unit, check for damage. Claims for damage must be made at the receiving end through the delivery carrier. Damage cannot be processed from the factory.

▲ DANGER **RISK OF FIRE OR EXPLOSION.** Before handling these pumps and controls, always disconnect the power first. Do not smoke or use sparkable electrical devices or flames in a septic (gaseous) or possible septic sump. Do not pump flammable liquids with this pump.

PUMPS IN STORAGE OR NOT OPERATING

Pumps with silicon/carbide seals must have impellers manually rotated (6 revolutions) after setting non-operational for 3 months or longer and prior to electrical start-up.

SEAL FAILURE PROBES

HAZARDOUS DUTY RATED PUMPS:

All submersible pumps have two factory installed moisture detectors (seal failure probes). They should have a resistance of around 330K ohms for the series circuit in the seal chamber. Under normal operating conditions, the circuit remains around 330K ohm. If the circuit shows open the circuit is not complete indicating a broken wire, corroded wire, or loose connection. If the lower seal leaks and moisture enters this chamber, the moisture would settle to the bottom of the chamber and will complete (significantly less than 330K ohms) the circuit between the moisture detectors.

NON-HAZARDOUS DUTY RATED PUMPS:

For all non-hazardous duty rated pumps the resistance(ohm) readings between the seal probe wires should be open in normal operating conditions. A lower resistance indicates water intrusion.

This circuit must be connected to a sensing unit and signaling device. This is supplied in a manufacturer built control panel. Failure to install such a device negates all warranties.

HEAT SENSORS

All motors in this family have heat sensors on or embedded in the motor winding to detect excessive heat. This prevents damage to the motor. If sensor trips due to excessive winding temperature, the starter in the panel interrupts power to the pump. **The sensors are set to trip at 130°C.**

Failure to install such circuitry would negate FM approvals and all warranties.

POWER CORDS

The power cord and heat sensor seal failure cord are potted into the cord cap. The cords must not be spliced.

Each cable has a green lead. This is the ground wire and must be grounded properly per NEC and/or local codes. Cords should be inspected for abnormal wear and replaced accordingly.

OVERLOAD HEATERS

If the electrical panel is not used, starters with 3 leg overload relay must be supplied on 3 phase pumps. Each leg is to have an identical heater sized in accordance with the nameplate amps on the motor housing. The amp draw on these submersible motors is slightly higher than a corresponding horsepower surface motor, so heaters must be sized by the nameplate rating.

INSTALLING SUMP LEVEL CONTROLS FLOAT CONTROLS

In all systems, the lower or turn-off control is to be set to maintain a minimum level in the sump. This level shall be no more than 3-1/4" from the top of the motor housing down to the surface of the sewage.

The second or turn-on control is set above the lower turn-off control. The exact distance between the two floats must be a compromise between a frequent pumping cycle (15 starts per hour max.) to control septicity, solids and a slower cycle for energy economy. This distance should be determined by the engineer or consulting engineer, depending on the conditions of the application.

INSTALLING PUMP IN SUMP

Before installing the pump in the sump, lay it on its side and rotate impeller. Impeller may be slightly stuck due to factory test water. The impeller should turn freely. **Do not** connect the power until after this test.

Clean all debris from sump and connect pump to piping. A check valve must be installed on each pump and a gate or plug valve in each pump discharge is highly recommended. This valve should be installed on the discharge side of the check valve so if it becomes necessary to service the check valve, the line pressure can be cut off. Single pump systems are sometimes installed without a check valve where it is desirable to self-drain the discharge line to prevent freezing. This can be done only with short discharge lines; otherwise water will return to the sump and cause short cycling of the pump.

INSTALLATION

MAKING ELECTRICAL CONNECTIONS



Risk of electrical shock.
Can burn or kill.
Do not lift pump by
power cord.

⚠ DANGER ELECTROCUTION HAZARD: Must be

installed by a qualified professional. Disconnect all electrical power before installation or servicing the pump.

All electrical wiring must be in accordance with local codes, and only competent electricians should make the installations. Complete wiring diagrams are glued to the inside cover of the panel. It is VERY IMPORTANT to check all wires for grounds with an ohmmeter or Megger meter after the connections are made **as one grounded wire can cause considerable trouble.**

NOTICE: FM rated models are only to be used in 60hz applications.

IMPORTANT: If equipment is not properly wired and protected as recommended, the warranty is void.

⚠ CAUTION The 230 volt 3 phase pump has a dual marked nameplate. For ordinary location pumps, voltage may be rewired by qualified personnel. For hazardous location pumps, voltage may be rewired by the manufacturer or a Class I, Div I equipment qualified electrician. Once the voltage is changed, the factory cord tag indicating 230 volt 3 phase must be removed.

For record keeping purposes, we suggest the pump be marked externally with the new voltage and qualified personnel that performed the change. Pumps shipped from the factory as 460 volt 3 phase cannot be rewired to any other voltage.

TO RE-WIRE THE PUMP FROM 230V TO 460V 3 PHASE

Only a 230V pump from the factory is considered dual voltage, a cord label clearly states the factory wound voltage.

1. Remove all six (#7) cap screws then raise the cord cap assembly enough to slip a prying instrument on opposite sides between the cord cap casting and the motor housing. Take care to not damage the o-ring or the machined surfaces of the castings. Doing so could void FM agency certifications.
2. While prying evenly on both sides; separate the cord cap casting from the motor housing, the assembly is airtight and will have a vacuum effect when disassembling.
3. Once separated, the cord cap can be inverted and rotated to the outside of the pump assembly, and a bolt can be re-used to secure the upside down cord cap to the motor housing for ease of rewiring.

Refer to the wiring diagram within this manual for wiring details. Once all electrical connections are finished and secure (a crimped electrical connector is best to prevent issues due to vibration if required), the cord cap should be re-attached reversing the steps above. Ensure the o-ring is in place and perform a hi-pot test for safety once everything is complete.

HEAT SENSORS AND SEAL FAILURE CONNECTIONS

Be sure heat sensor wires are connected in series with the starter coil. Connections are provided on the terminal strip.

NUMBER OF CONDUCTORS REQUIRED BETWEEN CONTROL PANEL AND NEMA 4 JUNCTION BOX

Power lines and control wires can be carried in conduit or can be underground buried cable

SYSTEM TYPE	NUMBER OF CONTROL WIRES	NUMBER OF POWER LINES	NUMBER OF GROUND WIRES #8	HEAT SENSOR & SEAL FAILURE	
				NUMBER OF SENSOR WIRES	NUMBER OF GROUND WIRES
Simplex	4	3	1	3	1
Simplex with Alarm	6	3	1	3	1
Duplex	6	6	2	6	2
Duplex with Alarm	8	6	2	6	2

DUAL VOLTAGE
3 PHASE MOTOR WIRING

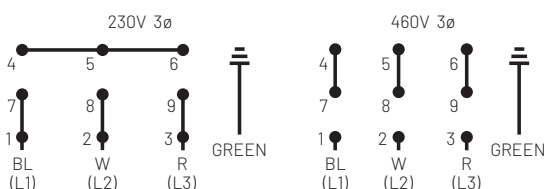

HEAT SENSORS AND SEAL FAILURE CONNECTIONS
FOR ANY VOLTAGE MOTOR

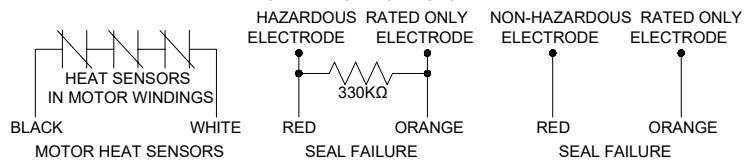

OPERATIONS & MAINTENANCE

⚠ DANGER RISK OF FIRE OR EXPLOSION. Do not smoke or use open flames in or around this system. Only the FM listed products are to be used in a hazardous location applications per NFPA 70 National Electric Code. Do not pump flammable liquids. Do not use non-hazardous pumps in explosive environments.

⚠ DANGER CUTTING RISK. Risk of serious cutting or amputation exists. Always keep fingers and hands away from cutting profiles. Disconnect all power sources prior to servicing pump. Pump may start without warning. Use caution as liner plate is extremely sharp.

PUMP OPERATIONS STARTING SYSTEM

1. Double check all wire connections.
2. Turn pumps to Off position on H-O-A switches.
3. Turn on breakers.
4. Connect amprobe to pump power cord and turn pump on. The pump will show high amp draw momentarily, then as pump approaches normal running speed, amps will drop to normal nameplate amps.
5. When using three phase pumps (208/230/460/575), turn the H-O-A switch to Hand position on one pump and notice operation. If pump is noisy and vibrates, rotation is wrong. To change rotation, interchange any two line leads to pump. Do not interchange main incoming lines. Check rotation of all pumps in this same manner.
6. Now set both H-O-A switches to Auto position and allow water to rise in sump until one pump starts. Allow pump to operate until the level drops to turn-off point.
7. Allow sump level to rise to start other pump(s). Notice run lights in panel. Pumps should alternate on each successive cycle of operation.
8. Turn both H-O-A switches to Off position and allow sump to fill to the override control level(s).
9. Turn switches to Auto position, and pumps should start and operate together until level drops to turn-off point.
10. Repeat this operation and cycle several times before leaving the job.
11. Check voltage when pumps are operating and check the amp draw of each pump. Check amps on each pump conductor as sometimes a high leg will exist. For excessive voltage on one leg, the electric utility company should be consulted.

PUMP MAINTENANCE

As the motors are oil filled, no lubrication or other maintenance is required.

ON HAZARDOUS DUTY RATED PUMPS ONLY: If the heat sensor and seal failure are hooked up properly, no attention is necessary as long as the seal failure indicator light does not come on. To ensure continuity of the seal sensor leads, a test light is provided on intrinsically safe panels as standard equipment.

⚠ WARNING Before handling these pumps and controls, always disconnect the power first. Do not smoke, use flames or devices that can produce electrical discharge or sparks in a septic (gaseous) or possible septic sump.

FIELD SERVICE ON ORDINARY LOCATION PUMPS

Ordinary location submersible motors that are out of warranty can be serviced in the field by any reliable motor service shop.

Any pump that is in warranty must be returned to the factory for service or repaired at an authorized service center. Charges will not be allowed if (in warranty) pump is not taken to an authorized service center. When field service is performed on a pump, these instructions should be carefully followed.

FIELD SERVICE ON HAZARDOUS LOCATION PUMPS

Hazardous location pumps must be returned to the factory for electrical and motor service. Any repair not at an authorized service center will void the Factory Mutual (FM) listing. This will ensure the integrity of the hazardous location rating of the pump and comply with our warranty requirements.

The cartridge seal, volute, liner, and impeller may be repaired or replaced by an authorized service facility without compromising the hazardous location rating to the pump.

For any repairs in which the oil is drained, the pump must be re-filled with an approved oil. The motor chamber cannot be disassembled during repairs as this will result in loss of agency rating.

Any time a seal is disturbed, it must be replaced.

Check the pump for proper rotation before returning to service.

OPERATIONS & MAINTENANCE

ADJUST CUTTER CLEARANCE ON CHOPPING MECHANISM

⚠ DANGER



⚠ DANGER CUTTING RISK. Risk of serious cutting or amputation exists. Use caution as liner plate is extremely sharp. Always keep fingers and hands away from cutting profiles. Disconnect all power sources prior to servicing pump. Pump may start without warning.

1. First install the liner plate with chopper bar (Item A) into the volute. It may be helpful to install 3/8-16 studs into the liner plate to line up the holes with the corresponding volute holes. You may have to tap the plate all the way down with a rubber hammer.
2. Remove the studs and replace with four 3/8-16 bolts (Item B) in the large counterbored holes from beneath the volute, only thread in enough to hold screws in place.
3. Install motor with impeller mounted, tighten motor housing bolts to volute.
4. Tighten four 3/8-16 (Item C) socket head cap screws in the chamfered counterbored holes until liner plate is sitting flat against impeller, ensure (Item B) is still loose which allows the liner plate to rest against the impeller.
5. Next back off the same 3/8-16 (Item C) screws away from liner plate 1/8 - 1/4 turn for the recommended .008-.015 clearance.
6. Tighten the opposite four 3/8-16 (Item B) screws evenly to 25-30 Ft-lbs. Ensure all screws have proper torque to prevent backing out. A thread locking compound is recommended to prevent vibrational loosening over time.
7. Measure the clearance with a feeler gauge it should be between .008 to .015.
8. Spin impeller with a hex wrench in the impeller hub or use a wooden pry bar to spin impeller to make sure there is no rub.
9. If you hear or feel a rub, readjust the clearance by loosening screws (Item C) evenly and retightening (Item B) screws.

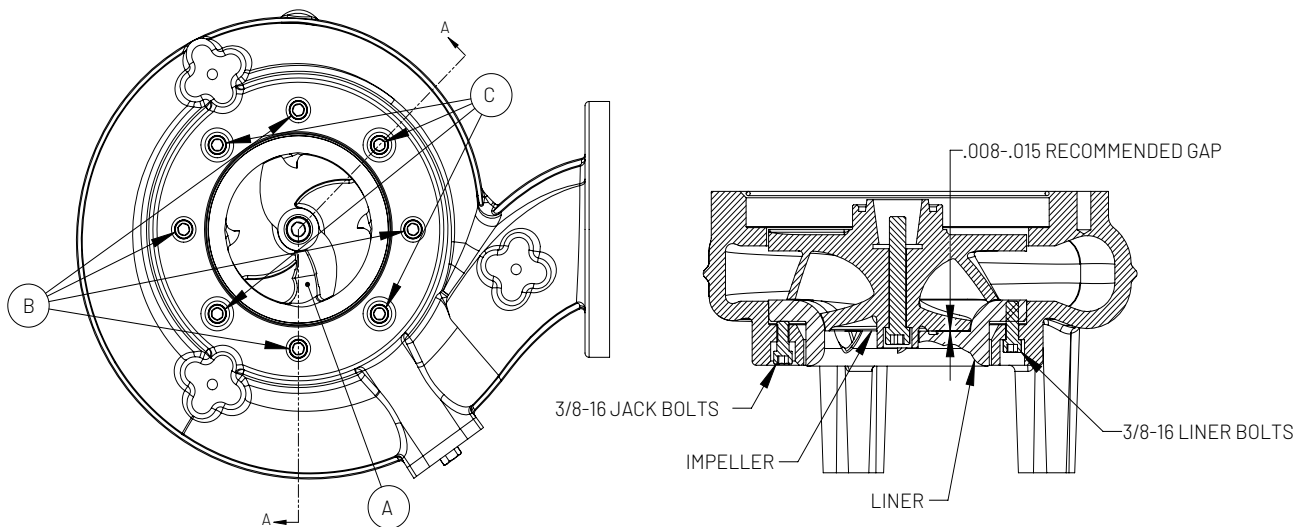

TROUBLESHOOTING

PUMP TROUBLESHOOTING

Below is a list of common problems and the probable causes

PUMP WILL NOT START

1. No power to the motor. Check for blown fuse or open circuit breaker.
2. Selector switch may be in the Off position.
3. Control circuit transformer fuse may be blown.
4. Overload heater on starter may be tripped. Push to reset.

PUMP WILL NOT START AND OVERLOAD HEATERS TRIP

1. Turn off power and check motor leads with Megger or ohmmeter for possible ground.
2. Check resistance of motor windings. All 3 phases should exhibit the same reading.
3. If no grounds exist and the motor windings check OK, remove pump from sump and check for clogged or blocked impeller.

PUMP OPERATES WITH SELECTOR SWITCH IN HAND POSITION BUT WILL NOT OPERATE IN AUTO POSITION

1. This indicates trouble in the float level control or the alternator relay.
2. Check control panel for trouble.

PUMP RUNS BUT WILL NOT SHUT OFF

1. Pump may be air locked. Turn pump off and let set for several minutes, then restart.
2. Lower float control may be hung-up in the closed position. Check in sump to be sure control is free.
3. Selector switch may be in the Hand position.

PUMP DOES NOT DELIVER PROPER CAPACITY

1. Discharge gate valve may be partially closed or partially clogged.
2. Check valve may be partially clogged. Raise level up and down to clear.
3. Pump may be running in wrong direction. Low speed pumps can operate in reverse direction without much noise or vibration.
4. Discharge head may be too high. Check total head with gauge when pump is operating. Total head is discharge gauge pressure converted to feet plus vertical height from water level in sump to center line of pressure gauge in discharge line. Gauge should be installed on pump side of all valves. Multiply gauge pressure in pounds by 2.31 to get head in feet.
5. If pump has been in service for some time and capacity falls off, remove pump and check for wear or clogged impeller.

MOTOR STOPS AND THEN RESTARTS AFTER SHORT PERIOD BUT OVERLOAD HEATERS IN STARTER DO NOT TRIP

1. This indicates heat sensors in the motor are tripping due to excessive heat. Impeller may be partially clogged giving a sustained overload but not high enough to trip overload heater switch.
2. Motor may be operating out of liquid due to a failed level control.
3. Pump may be operating on a short cycle due to sump being too small or from water returning to sump due to a leaking check valve.

IF YOU HAVE ANY QUESTIONS REGARDING THE INSTALLATION, OPERATION, MAINTENANCE OR TROUBLESHOOTING OF THE PUMP, PLEASE CALL PENTAIR AT 855-274-8947.

PARTS LIST

HPS4SD(X), HPS4HD(X), HPS6MD(X)

For use with product built with Premium Efficient motor.

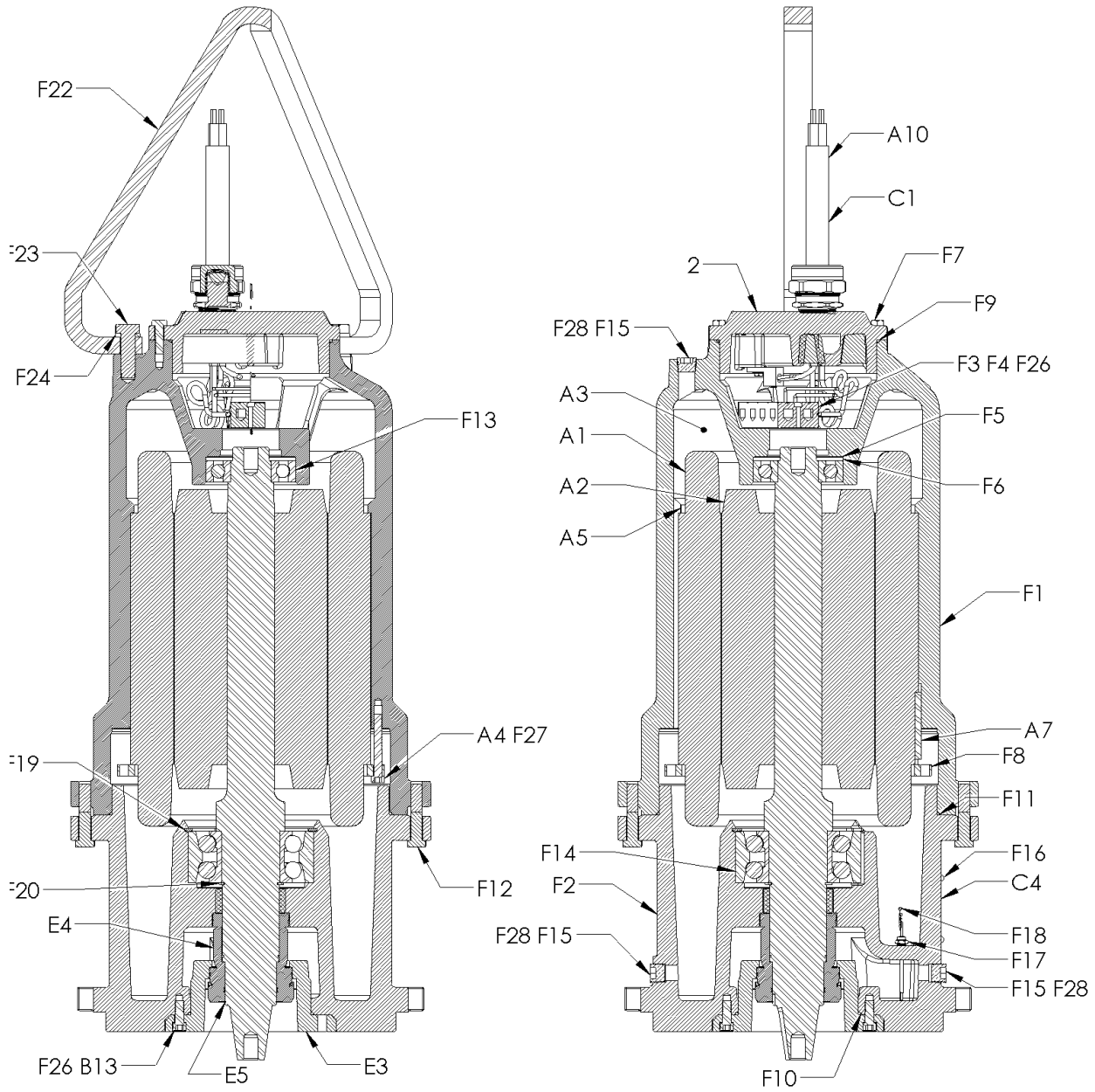

PARTS LIST

ITEM	PART DESCRIPTION	PART #	4SD / 4HD / 6MD
2	CORD CAP 10-4 35'	152880315	*
2	CORD CAP 8-4 35'	152880325	*
2	CORD CAP 6-4 35'	152880335	*
A1	STATOR	SEE MOTOR PARTS GROUP	1
A2	ROTOR/SHAFT ASSEMBLY	SEE MOTOR PARTS GROUP	1
A5	SPACER	SEE MOTOR PARTS GROUP	1
A3	OIL	153620017	—
A4	BOLT-STATOR	06106A027	4
A6	ELECTRICAL CONNECTOR 460V ONLY	12672A001	1
A7	STATOR KEY	05818A012	1
B13	SCREW SOCKET HEAD SEAL PLATE TO BRG HSG	06106A028	4
C1	CORD SEAL FAILURE DIAGRAM	134241141	1
C4	NAMEPLATE	134256901	1
E3	HOUSING-SEAL PLATE 250 FRAME PREM EFF	107550352	1
E4	SEAL-CARTRIDGE, 250 HPE SC/C 2.5&2.25	154732501K	1
E5	RING - RETAINING EXTERNAL BRG	12558A036	1
F1	HOUSING-MOTOR	28011D000	1
F2	HOUSING-BEARING	27808D525	1
F3	TERMINAL BLOCK	27882A009	1
F4	SCREW-CAP SKT HD. TERMINAL BLK	06106A069	2
F5	SCREEN	110650043	1
F6	WASHER-SPRING (THRUST)**	19331A009	1
F7	SCREW-CAP CORD CAP TO MTR HSG	19101A017	6
F8	RING-STATOR	026030003	1
F9	O-RING CORD CAP**	001500191	1
F10	O-RING SEAL PLATE**	05876A112	1
F11	O-RING MOTOR HOUSING**	05876A178	1
F12	SCREW-CAP MTR HSG TO BRG HSG	19103A048	8
F13	BEARING-BALL UPPER**	08565A026	1
F14	BEARING-BALL ANG. CONTACT DBL ROW**	071670171	1
F15	PLUG-PIPE 1/2" SKT HD.	009240101	3
F16	SCREW-DRIVE #6	045800011	4
F17	PROBE-SEAL FAILURE**	109010021	2
F18	SEAL-SENSOR ASS'Y**	109000045	1
F19	RING-RETAINING EXTERNAL BRG**	12558A036	1
F20	RING-RETAINING INTERNAL BRG**	009740041	1
F22	LIFTING BAIL	25371B008	1
F23	LIFTING BAIL BOLTS	19105A038	2
F24	LIFTING BAIL LOCK WASHER	05454A027	2
F26	LOCTITE® 242 - BLUE (ITEMS ARE NOT FOR SALE)	NOT INCLUDED	1
F27	LOCTITE® 277 - RED (ITEMS ARE NOT FOR SALE)	NOT INCLUDED	1
F28	SEALANT - PIPE (ITEMS ARE NOT FOR SALE)	NOT INCLUDED	1
	REPAIR KIT (** KIT PARTS)	528692507	—
	CARTRIDGE SEAL PULLER	26836A100	1

* Cord size is dependent upon model.

** Included with Repair Kit.

All parts listed are saleable unless otherwise noted.

PARTS LIST

HYDRAULIC ENDS PARTS LIST

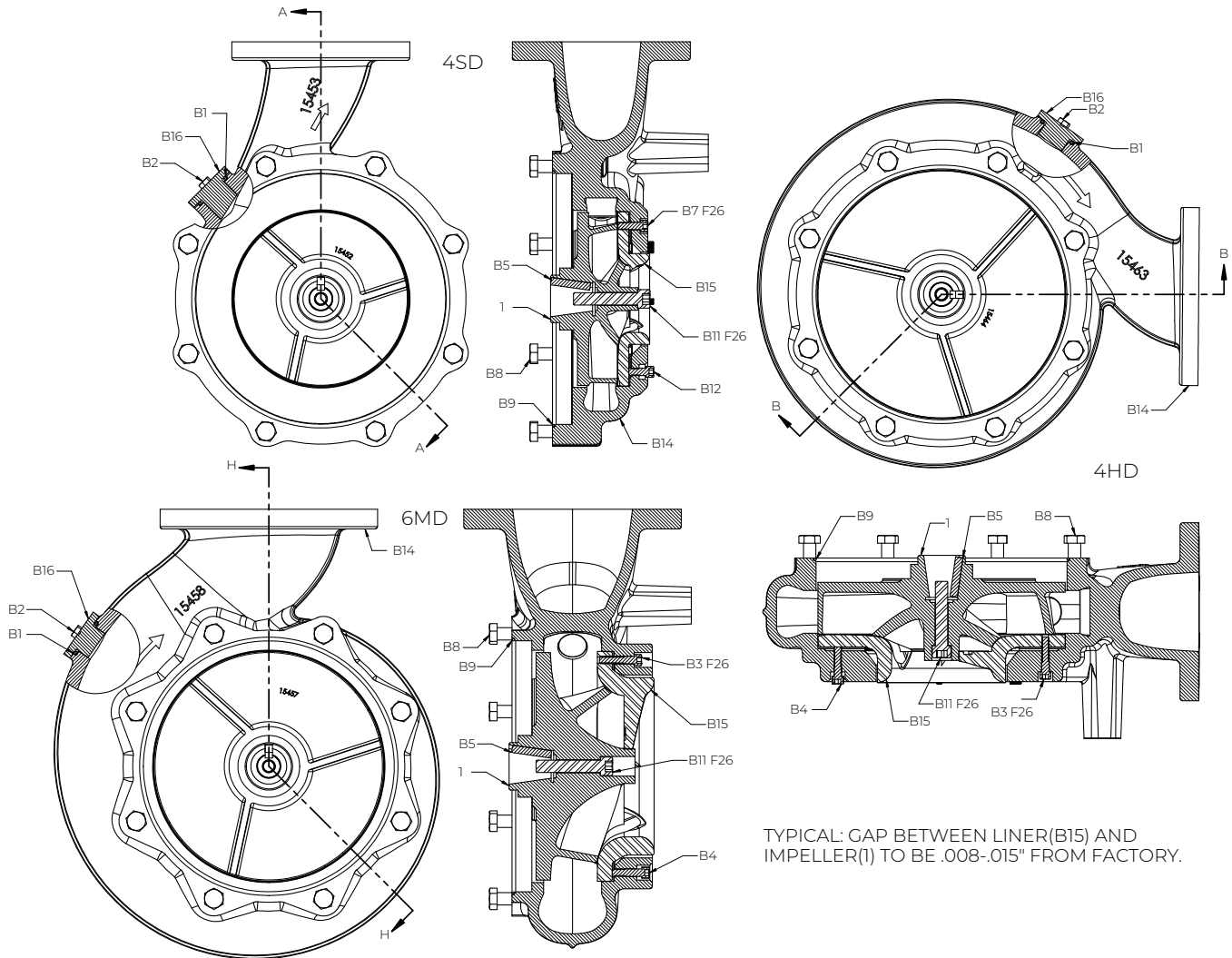

ITEM	DESCRIPTION	PART #	4SD	4HD	6MD
B1	O-RING VOL COVER **	05876A108	1	1	1
B2	SCREW-HEX HEAD VOL COVER	002380301	2	2	2
B3	SCREW-SOCKET HEAD CAP LINER BOLT	005560081	—	4	4
B4	SCREW-SOCKET HEAD LINER JACK BOLT	005560211	—	4	4
B5	KEY 3/8 X 3/8 SHAFT TO IMP **	05818A010	1	1	1
B7	SCREW-SOCKET HEAD LINER BOLT	005560201	4	—	—
B8	SCREW-HEX HEAD VOL TO BRG HSG	005700601	8	8	8
B9	O-RING VOL TO SEAL PLATE **	05876A178	1	1	1
B11	SCREW-SOCKET HEAD IMP BOLT	029190141	1	1	1
B12	SCREW-SOCKET HEAD LINER JACK BOLT	005560191	4	—	—
B14	VOLUTE	CHARTED	154530002	154630002	154580002
B15	LINER CHOPPER	CHARTED	154540002	154620002	154590002
B16	VOLUTE COVER	CHARTED	154720002	154720012	154720012

** Included with Repair Kit.

PARTS LIST

MOTOR PARTS LIST

ITEM	2-POLE 3450 RPM	25HP	25HP	30/40HP	30/40HP
		230/460/3/60	575/3/60	460/3/60	575/3/60
A1	STATOR	27906D003	27906D603	27907D003	27907D603
A2	ROTOR/SHAFT ASSEMBLY	27906D130	27906D130	27907D130	27907D130
A3	OIL	153620017	153620017	153620017	153620017
A4	BOLT-STATOR	06106A027(4)	06106A027(4)	06106A027(4)	06106A027(4)
A5	SPACER	076650041	076650041	076650011	076650011
A7	STATOR KEY	05818A012	05818A012	05818A012	05818A012

ITEM	4-POLE 1750 RPM	25HP	25HP	30HP	30HP	40HP	40HP
		208-230/460/3/60	575/3/60	230/460/3/60	575/3/60	460/3/60	575/3/60
A1	STATOR	27902D003	27902D603	27903D003	27903D603	27904D003	27904D603
A2	ROTOR/SHAFT ASSEMBLY	27902D130	27902D130	27903D130	27903D130	27904D130	27904D130
A3	OIL	153620017	153620017	153620017	153620017	153620017	153620017
A4	BOLT-STATOR	06106A027(4)	06106A027(4)	06106A027(4)	06106A027(4)	06106A071(4)	06106A071(4)
A5	SPACER	076650041	076650041	076650011	076650011	—	—
A7	STATOR KEY	05818A012	05818A012	05818A012	05818A012	05818A005	05818A005

IMPELLER PARTS LIST - HPS4SD(X) 3450 RPM

DESCRIPTION	PART #	HP	VOLTAGE/PH	CORD	TRIM	IMPELLER
HPS4SDP025223	528630027	25	230-460/3	4-4	7.38	154521112
HPS4SDP025243	528630037	25	460/3	8-4	7.38	154521112
HPS4SDP025253	528630047	25	575/3	8-4	7.38	154521112
HPS4SDXP025223	528636027	25	230-460/3	4-4	7.38	154521112
HPS4SDXP025243	528636037	25	460/3	8-4	7.38	154521112
HPS4SDXP025253	528636047	25	575/3	8-4	7.38	154521112
HPS4SDP030243	528630117	30	460/3	8-4	7.88	154521072
HPS4SDP030253	528630127	30	575/3	8-4	7.88	154521072
HPS4SDXP030243	528636117	30	460/3	8-4	7.88	154521072
HPS4SDXP030253	528636127	30	575/3	8-4	7.88	154521072
HPS4SDP040243	528630137	40	460/3	6-4	8.63	154521012
HPS4SDP040253	528630147	40	575/3	8-4	8.63	154521012
HPS4SDXP040243	528636137	40	460/3	6-4	8.63	154521012
HPS4SDXP040253	528636147	40	575/3	8-4	8.63	154521012

PARTS LIST

IMPELLER PARTS LIST - HPS4HD(X) 1750 RPM

DESCRIPTION	PART #	HP	VOLTAGE/PH	CORD	TRIM	IMPELLER
HPS4HDP025403	528650017	25	208/3	4-4	10.75	154641142
HPS4HDP025423	528650027	25	230-460/3	6-4	10.75	154641142
HPS4HDP025443	528650037	25	460/3	8-4	10.75	154641142
HPS4HDP025453	528650047	25	575/3	8-4	10.75	154641142
HPS4HDXP025403	528656017	25	208/3	4-4	10.75	154641142
HPS4HDXP025423	528656027	25	230-460/3	6-4	10.75	154641142
HPS4HDXP025443	528656037	25	460/3	8-4	10.75	154641142
HPS4HDXP025453	528656047	25	575/3	8-4	10.75	154641142
HPS4HDP030423	528650127	30	230-460/3	4-4	11.5	154641082
HPS4HDP030443	528650137	30	460/3	8-4	11.5	154641082
HPS4HDP030453	528650147	30	575/3	8-4	11.5	154641082
HPS4HDXP030423	528656127	30	230-460/3	4-4	11.5	154641082
HPS4HDXP030443	528656137	30	460/3	8-4	11.5	154641082
HPS4HDXP030453	528656147	30	575/3	8-4	11.5	154641082
HPS4HDP040443	528650217	40	460/3	6-4	12.50	154641002
HPS4HDP040453	528650227	40	575/3	8-4	12.50	154641002
HPS4HDXP040443	528656217	40	460/3	6-4	12.50	154641002
HPS4HDXP040453	528656227	40	575/3	8-4	12.50	154641002

IMPELLER PARTS LIST - HPS6MD(X) 1750 RPM

DESCRIPTION	PART #	HP	VOLTAGE/PH	CORD	TRIM	IMPELLER
HPS6MDP025403	528640017	25	208/3	4-4	9.63	154571152
HPS6MDP025423	528640027	25	230-460/3	6-4	9.63	154571152
HPS6MDP025443	528640037	25	460/3	8-4	9.63	154571152
HPS6MDP025453	528640047	25	575/3	8-4	9.63	154571152
HPS6MDXP025403	528646017	25	208/3	4-4	9.63	154571152
HPS6MDXP025423	528646027	25	230-460/3	6-4	9.63	154571152
HPS6MDXP025443	528646037	25	460/3	8-4	9.63	154571152
HPS6MDXP025453	528646047	25	575/3	8-4	9.63	154571152
HPS6MDP030423	528640127	30	230-460/3	4-4	10.00	154571122
HPS6MDP030443	528640137	30	460/3	8-4	10.00	154571122
HPS6MDP030453	528640147	30	575/3	8-4	10.00	154571122
HPS6MDXP030423	528646127	30	230-460/3	4-4	10.00	154571122
HPS6MDXP030443	528646137	30	460/3	8-4	10.00	154571122
HPS6MDXP030453	528646147	30	575/3	8-4	10.00	154571122
HPS6MDP040443	528640217	40	460/3	6-4	11.25	154571022
HPS6MDP040453	528640227	40	575/3	8-4	11.25	154571022
HPS6MDXP040443	528646217	40	460/3	6-4	11.25	154571022
HPS6MDXP040453	528646227	40	575/3	8-4	11.25	154571022

WIRING DIAGRAMS

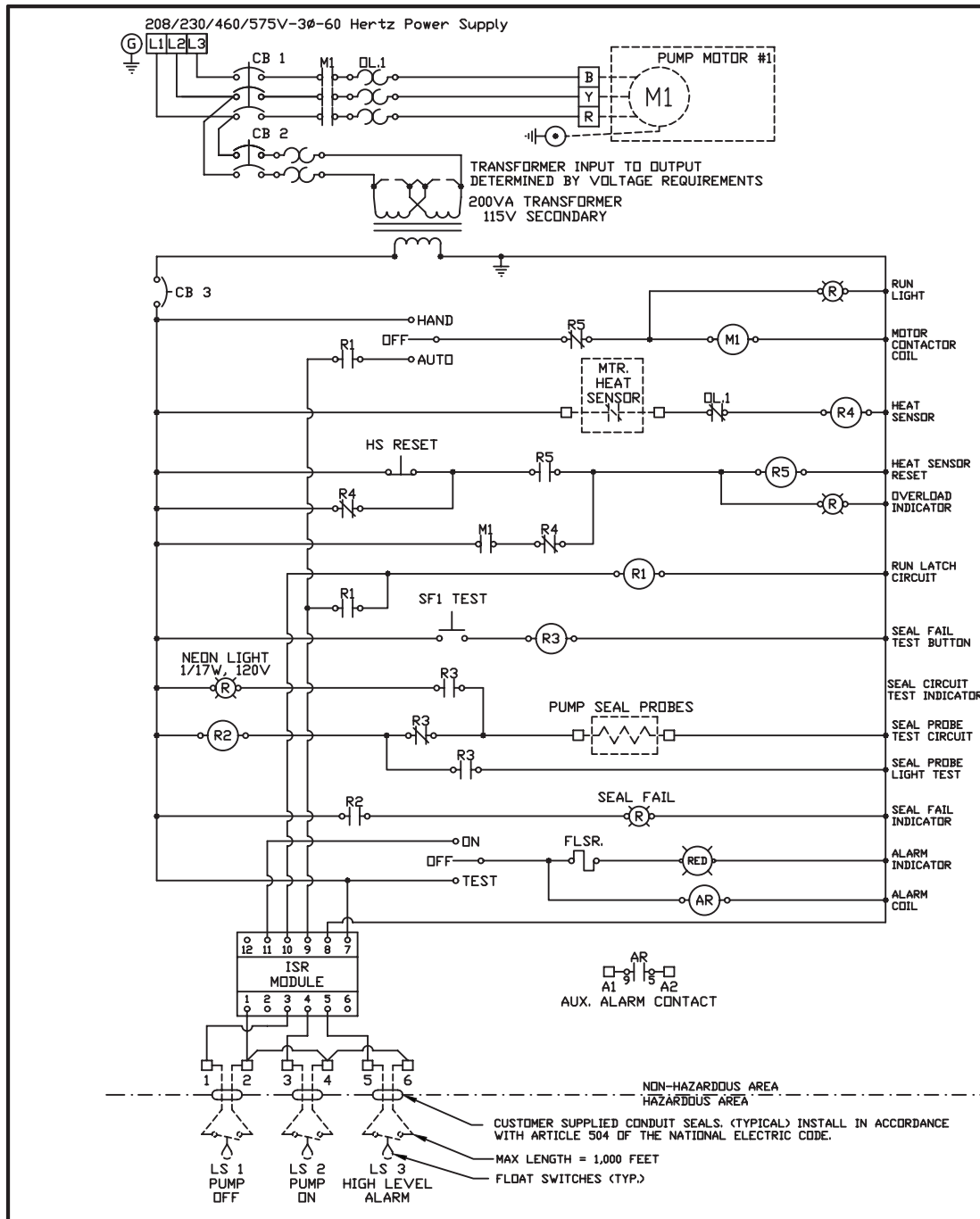

3 PHASE

Notes:

1. Level Switches Must be Rated a Minimum of 2 Amps at 120 Volts.
2. Torque all field wiring terminals to 20 in. Lbs.
3. Field Wiring Must be 60°C Copper Wire Minimum.
4. ----- = Items Not Supplied In Control Panel.
5. Pump power, heat sensor, and seal probe cables must pass through approved NEC 501.15 conduit seals.

WIRING DIAGRAMS

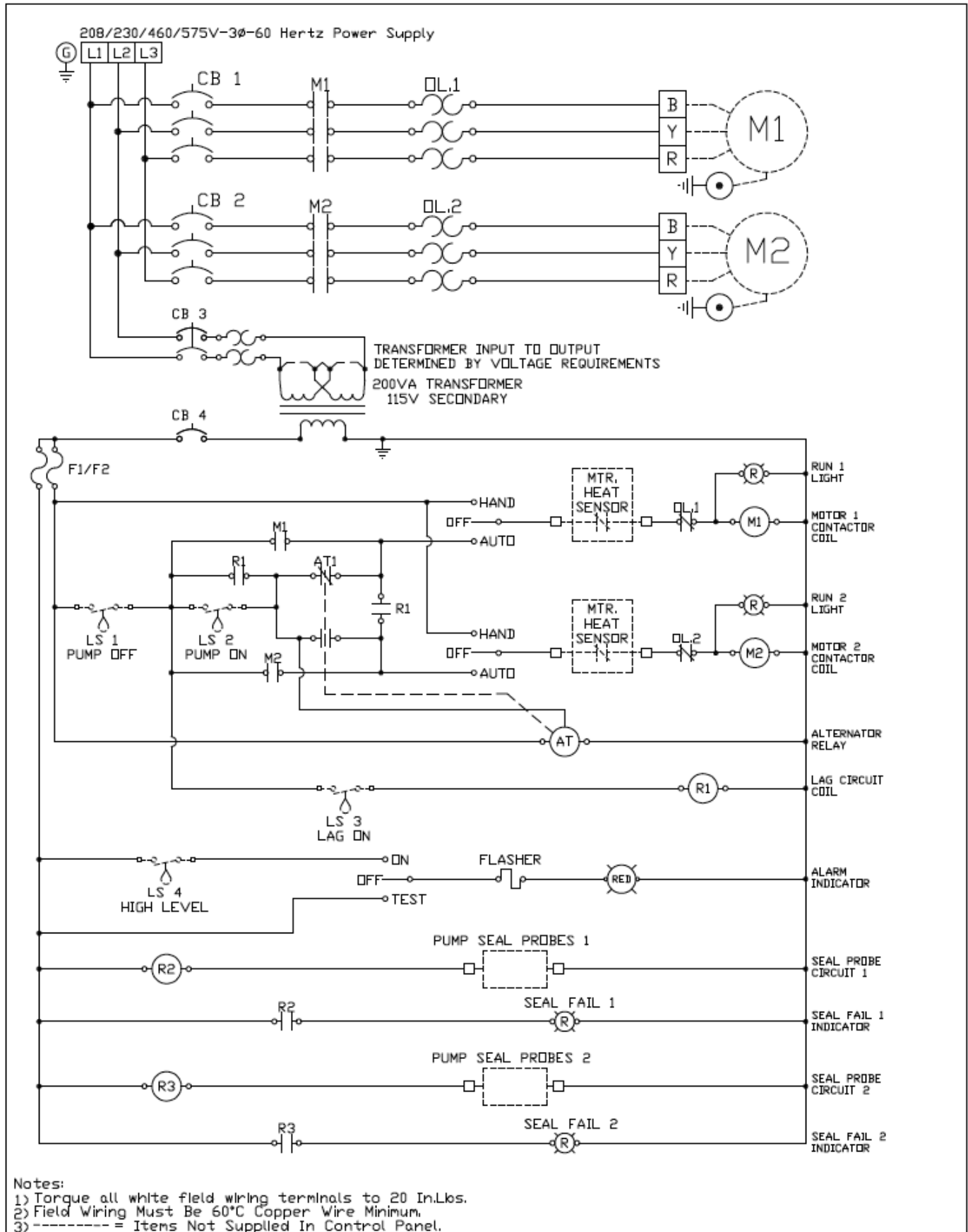

WARRANTY

Pentair Hydromatic® warrants its products against defects in material and workmanship for a period of 12 months from the date of shipment from Pentair Hydromatic or 18 months from the manufacturing date, whichever occurs first – provided that such products are used in compliance with the requirements of the Pentair Hydromatic catalog and technical manuals for use in pumping raw sewage, municipal wastewater or similar, abrasive-free, noncorrosive liquids.

During the warranty period and subject to the conditions set forth, Pentair Hydromatic, at its discretion, will repair or replace to the original user, the parts that prove defective in materials and workmanship. Pentair Hydromatic reserves the right to change or improve its products or any portions thereof without being obligated to provide such a change or improvement for prior sold and/or shipped units.

Start-up reports and electrical schematics may be required to support warranty claims. Submit at the time of start up through the Pentair Hydromatic website: <http://forms.pentairliterature.com/startupform/startupform.asp?type=h>. Warranty is effective only if Pentair Hydromatic authorized control panels are used. All seal fail and heat sensing devices must be hooked up, functional and monitored or this warranty will be void. Pentair Hydromatic will cover only the lower seal and labor thereof for all dual seal pumps. Under no circumstance will Pentair Hydromatic be responsible for the cost of field labor, travel expenses, rented equipment, removal/reinstallation costs or freight expenses to and from the factory or an authorized Pentair Hydromatic service facility.

This limited warranty will not apply: (a) to defects or malfunctions resulting from failure to properly install, operate or maintain the unit in accordance with the printed instructions provided; (b) to failures resulting from abuse, accident or negligence; (c) to normal maintenance services and parts used in connection with such service; (d) to units that are not installed in accordance with applicable local codes, ordinances and good trade practices; (e) if the unit is moved from its original installation location; (f) if unit is used for purposes other than for what it is designed and manufactured; (g) to any unit that has been repaired or altered by anyone other than Pentair Hydromatic or an authorized Pentair Hydromatic service provider; (h) to any unit that has been repaired using non factory specified/OEM parts.

Warranty Exclusions: PENTAIR HYDROMATIC MAKES NO EXPRESS OR IMPLIED WARRANTIES THAT EXTEND BEYOND THE DESCRIPTION ON THE FACE HEREOF. PENTAIR HYDROMATIC SPECIFICALLY DISCLAIMS THE IMPLIED WARRANTIES OF MERCHANTABILITY AND FITNESS FOR ANY PARTICULAR PURPOSE.

Liability Limitation: IN NO EVENT SHALL PENTAIR HYDROMATIC BE LIABLE OR RESPONSIBLE FOR CONSEQUENTIAL, INCIDENTAL OR SPECIAL DAMAGES RESULTING FROM OR RELATED IN ANY MANNER TO ANY PENTAIR HYDROMATIC PRODUCT OR PARTS THEREOF. PERSONAL INJURY AND/OR PROPERTY DAMAGE MAY RESULT FROM IMPROPER INSTALLATION. PENTAIR HYDROMATIC DISCLAIMS ALL LIABILITY, INCLUDING LIABILITY UNDER THIS WARRANTY, FOR IMPROPER INSTALLATION. PENTAIR HYDROMATIC RECOMMENDS INSTALLATION BY PROFESSIONALS.

Some states do not permit some or all of the above warranty limitations or the exclusion or limitation of incidental or consequential damages and therefore such limitations may not apply to you. No warranties or representations at any time made by any representatives of Pentair Hydromatic shall vary or expand the provision hereof.



1101 Myers Parkway
Ashland, OH 44805
Ph: 855.274.8947
Fx: 800.426.9446

490 Pinebush Road, Unit 4
Cambridge, Ontario, Canada N1t 0a5
Ph: 800.363.7867
Fx: 888.606.5484

pentair.com/hydromatic

Loctite® is a registered trademark of Henkel AG & Company KGaA.

All indicated Pentair trademarks and logos are property of Pentair. Third party registered and unregistered trademarks and logos are the property of their respective owners.

©2024 Pentair. All Rights Reserved.

E-03-601 / 056255651(06-21-24)