

ITEM NO.	PART NUMBER	DESCRIPTION	QTY.
1	12596	SHAFT	1
2	12211	BALL BEARING	2
3	05133	SPACER	1
4	04258	EXT. RETAINING RING	3
5	04259	INT. RETAINING RING	2
6	04264	FLAT WASHER	1
7	12314	TYPE 6A SEAL/SEAT ASSY	1
8	12328	BODY - MACHINED	1
9	12855	GASKET	1
10	12856	WEAR PLATE	1
11	12907	HOUSING - MACH	1
12	12231	O-RING	1
13	04432	WOODRUFF KEY	1
14	19995	SCREW 1/4-20 ROUND HD	1
15	19996	CAM WASHER	1
16	10944	CAM	1
17	10615	RUBBER IMPELLER	1
18	12926	HUB	1
19	12927	SLEEVE - SHAFT	1
20	09420	TAPER GROOVE PIN	1
21	12857	1/4-20 HHCS	3
22	12710	LOCKWASHER	3
23	13285	TAG	1
24	23083	LABEL	1

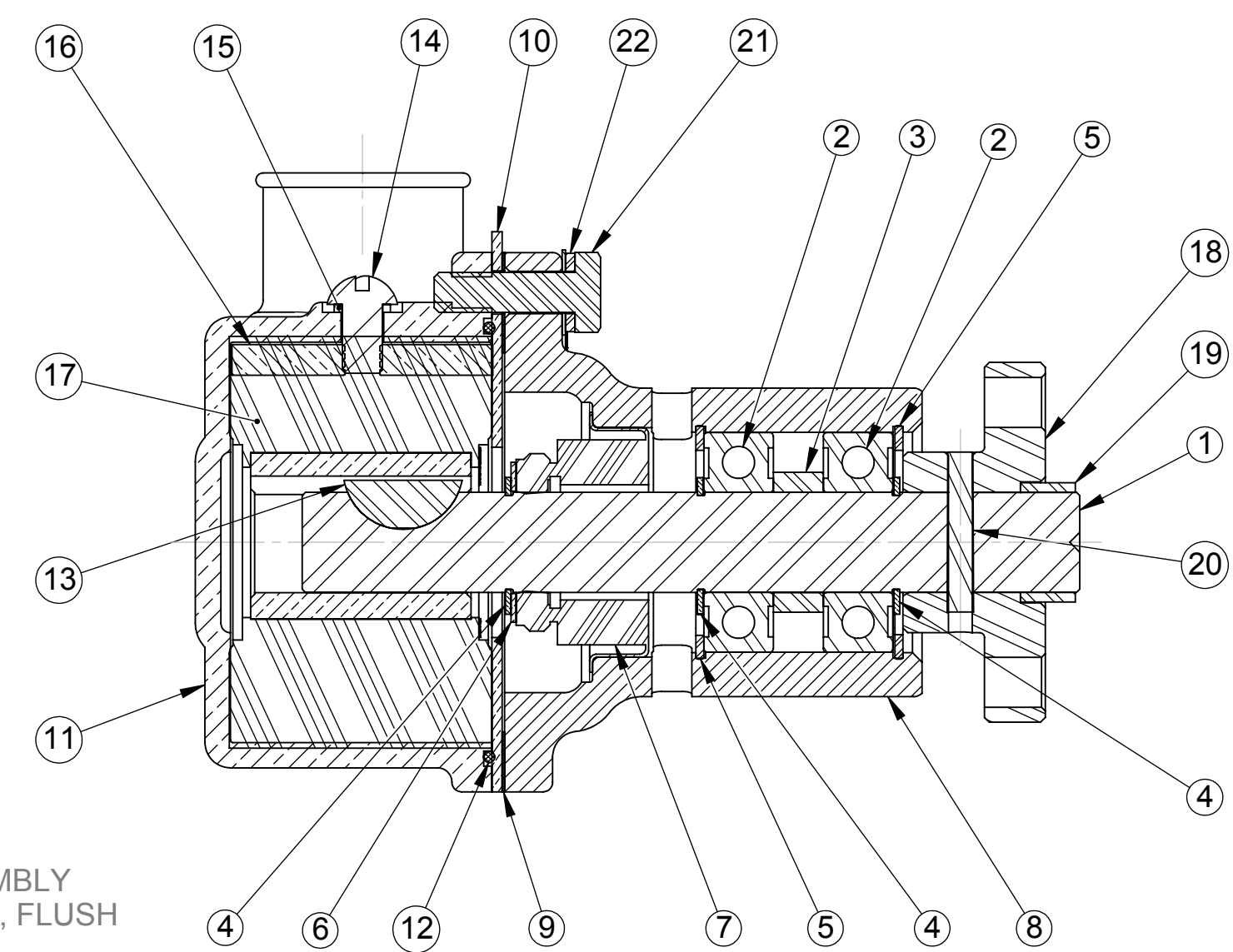
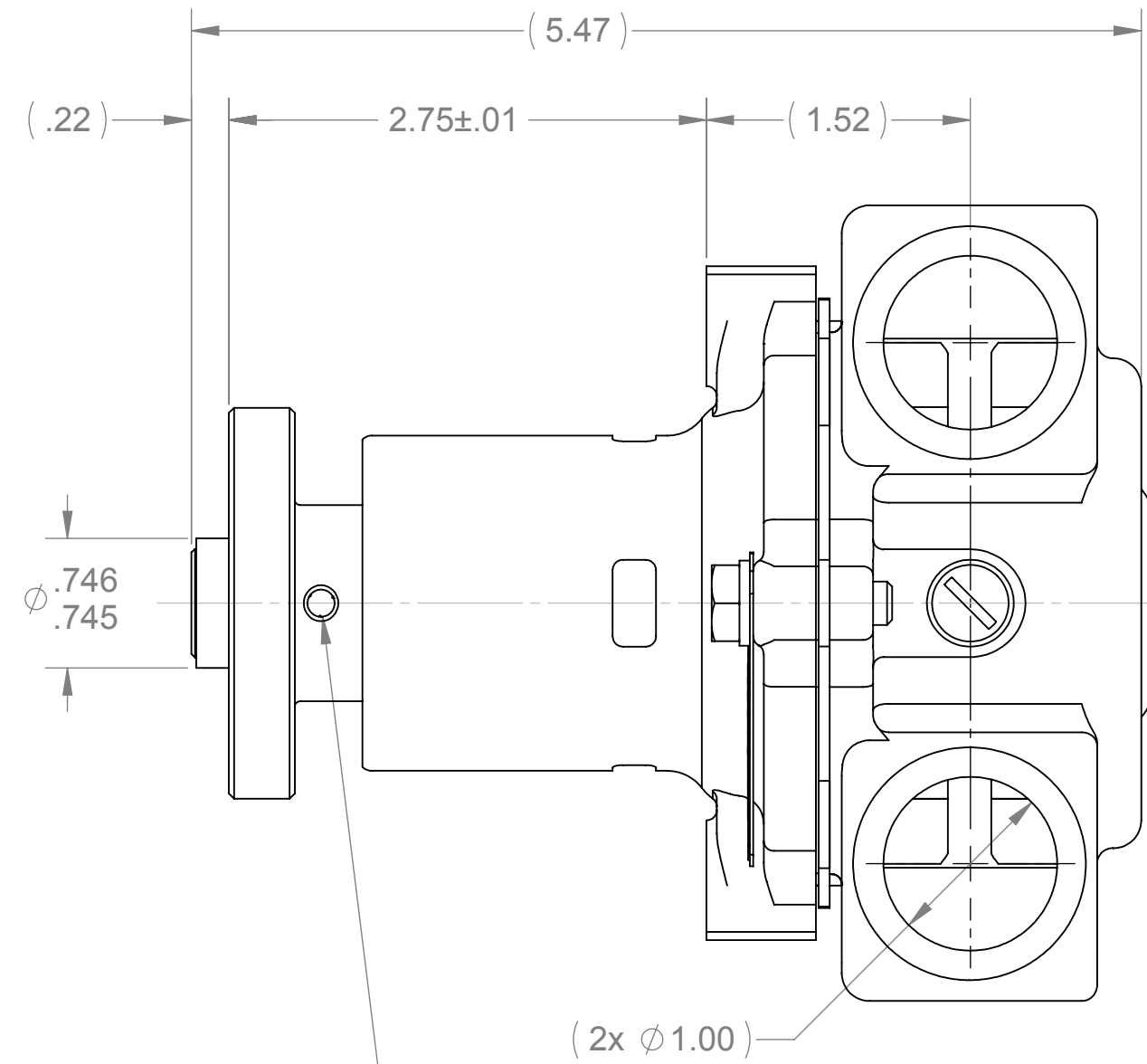

SECTION A-A

Ø 5/32" DRILL THRU TO OTHER SIDE AT ASSEMBLY
DEBURR. PRESS TAPER GROOVE PIN, ITEM 19, FLUSH

NOTES:

1. APPLY BEAD OF PERMATEX AROUND THREADED HOLE IN CAM PRIOR TO ASSEMBLY, (ITEM 16).
2. USE WATER ONLY WHEN INSTALLING TYPE 6A SEAL/SEAT ASSY, (ITEM 7).
3. USE COOLANT TO AID IN INSTALLATION OF RUBBER IMPELLER, (ITEM 17).
4. TORQUE 1/4-20 HHCS TO 5 - 8 FT/LBS, (ITEM 21).
5. PRESSURE TEST PUMP TO 20 - 30 PSI.
6. PRINT "G55" AND "DATE CODE" ON LABEL, (ITEM 24).

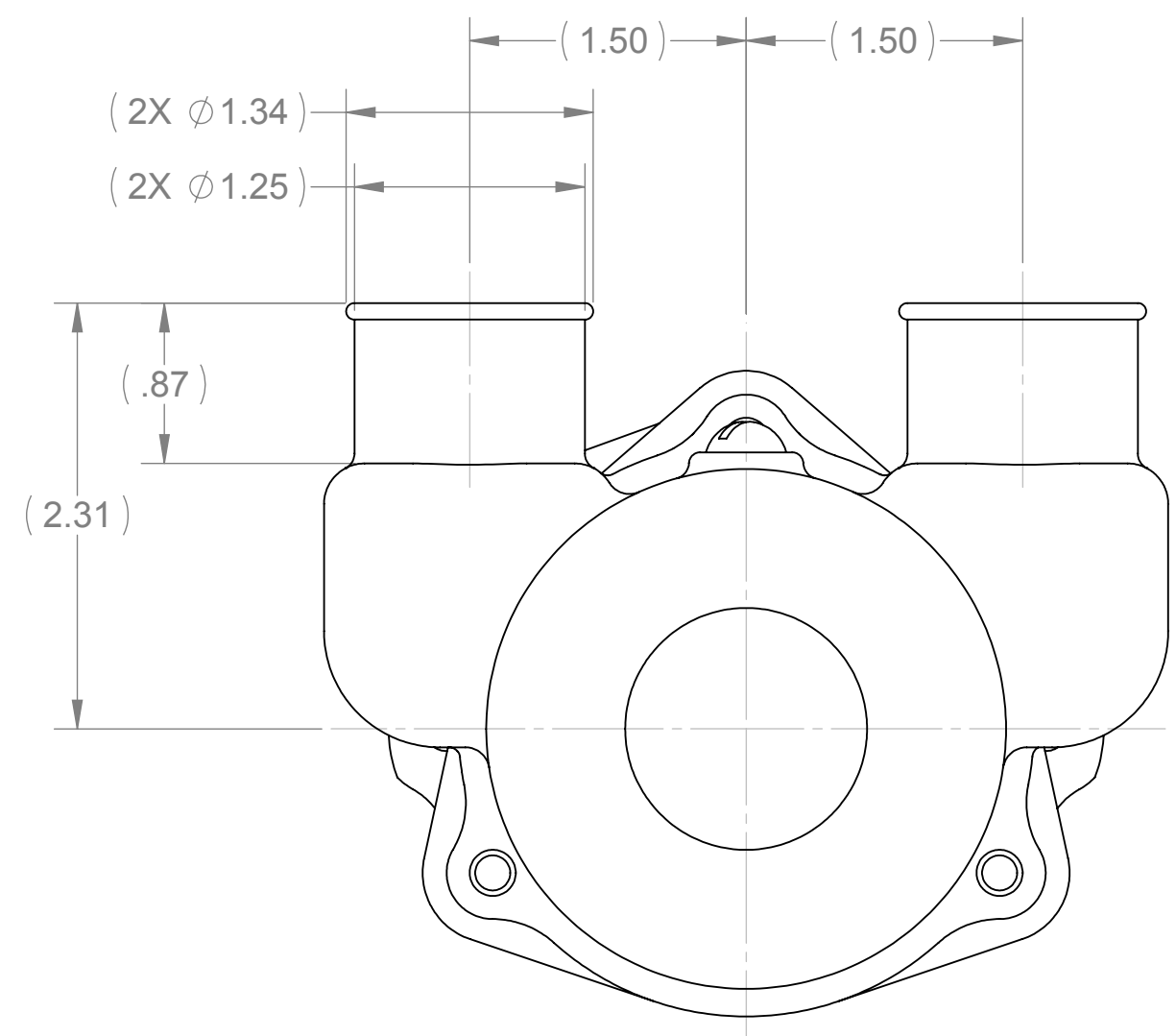
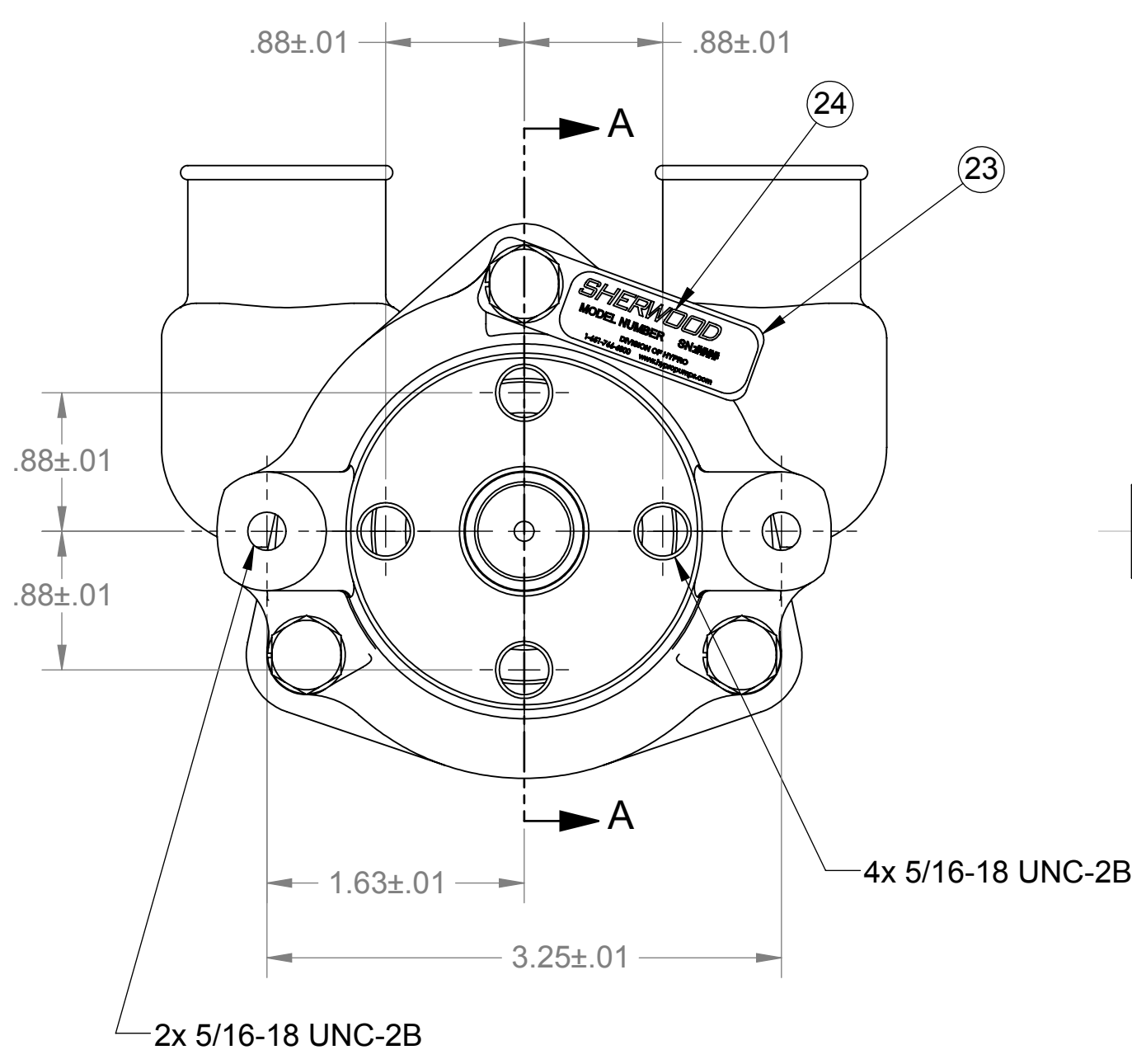

REV.	ECN.	DESCRIPTION	CHKD.	DATE
M	6830	CHANGED 12926 FROM SQUARE TO ROUND, UPDATED DRAWING	PEB	5/9/2008
L	6527	REMOVED 12256 SEAT ASSY. & 10515C CAM SCREW ASSY. ADDED 19995 CAM SCREW & 19996 CAM WASHER. NOTE 2 WAS "USE PAC-EASE OR EQUIV". REDIMENSIONED	PEB	11/15/2007
K	6195	ADDED NOTES, REDRAWN ON NEW FORMAT	PB	6/15/2007

SHERWOOD
A Div. of Hypro Corporation A PENTAIR COMPANY
375 Fifth Avenue NW, New Brighton, MN 55112, (651) 766-6300

DRAWING BASED ON ASME Y14.5M-1994 DO NOT SCALE PRINT

THIRD ANGLE PROJECTION

SCALE 1:1 SHEET NUMBER 1 OF 1

PART DESCRIPTION **RUBBER IMPELLER PUMP**

REPLACES PART NO. _____ REV. _____

DWG BY: BK DATE: 1/6/1978

CHECKED BY: AVB DATE: 3/14/1989

APPROVED BY: _____ DATE: _____

THIS DRAWING IS THE PROPERTY OF HYPRO, AND WITHOUT WRITTEN AUTHORIZATION, MUST NOT BE COPIED OR COMMUNICATED

PART NUMBER **G55-2** REV. **M**