

# STA-RITE® FH Series Shallow Well Jet Pump



The FH Series Jet Pump provides best-in-class performance for shallow wells up to 25' deep and flows over 20 GPM. Designed for the professional with heavy-duty cast iron construction, Noryl® internals and factory wired pressure switch for years of extended service. Available in 1/2 HP model.

## APPLICATIONS

Ideal for homes, farms and cottages.

## ORDERING INFORMATION

Catalog Number	HP	Length	Approx. Wt. Lbs.
FH50	1/2	18-5/8	40

## SPECIFICATIONS

**Pump Case** – Cast iron

**Diffuser** – Reinforced Polypropylene

**Seal Plate** – Cast iron

**Impeller** – Noryl®

**Mechanical Shaft Seal, Type 6** – Buna-N, Carbon, Ceramic, 18-8 stainless steel

**Nozzle** – Acetal

**Venturi Tube** – Acetal

**1/4" NPT Pipe Plug** – Zinc plated steel

**Mounting Base** – Steel

## FEATURES

**Precision Molded Noryl® Impeller with 300 grade Stainless Insert** – High performance and efficiency with high strength for longevity.

**Precision Molded Reinforced Polypropylene Diffuser, Nozzle and Venturi** – High performance and efficiency with superior abrasion resistance.

**Cast Iron Pump Case with 1-1/4" Suction and 1" Discharge Ports, Two 1/4" Auxiliary Pressure Ports and Cleanout Plug** – Facilitates plumbing of accessories and easy access to nozzle for cleanout.

**Rugged Cast Iron Seal Plate** – Positive alignment between pump case and motor.

**Factory Installed Pressure Switch with Fixed 20 lb. Differential and 1/4" FNPT Port** – Industry standard switch is easily field replaceable.

**Every Pump Unit is Factory Tested** – Peace of mind for you and your customers.

This product is Listed to UL and CSA Standards for Safety by CSA International.

Noryl® is a registered trademark of General Electric Co.  
All other brand or product names are trademarks or registered marks of Pentair Ltd.

# STA-RITE® FH Series Shallow Well Jet Pump

## OUTLINE DIMENSIONS

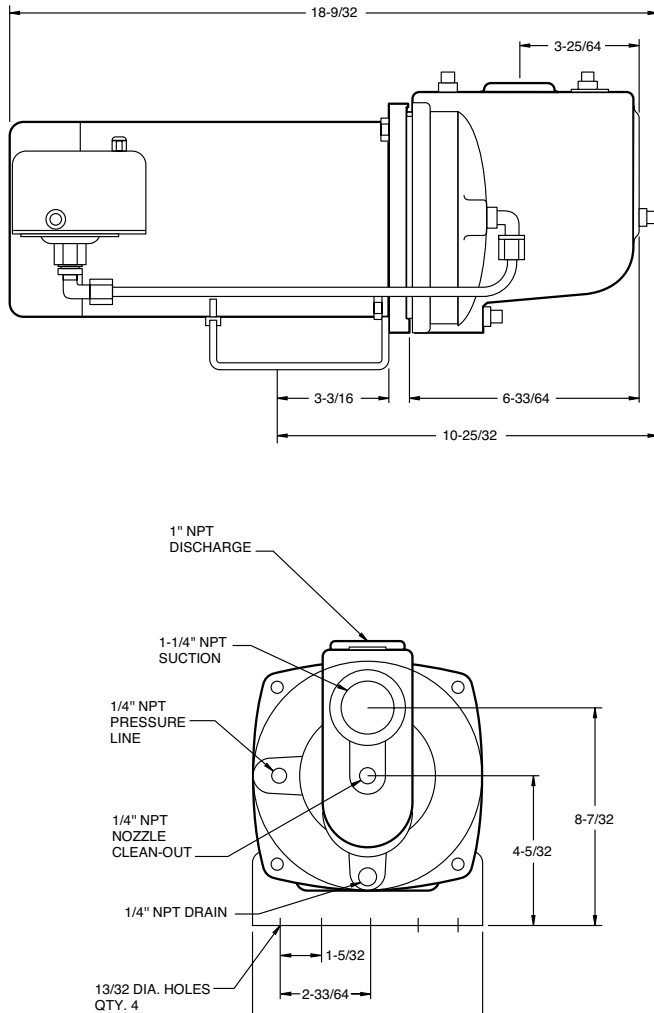

Dimensions (in inches) are for estimating purposes only.

## PUMP PERFORMANCE

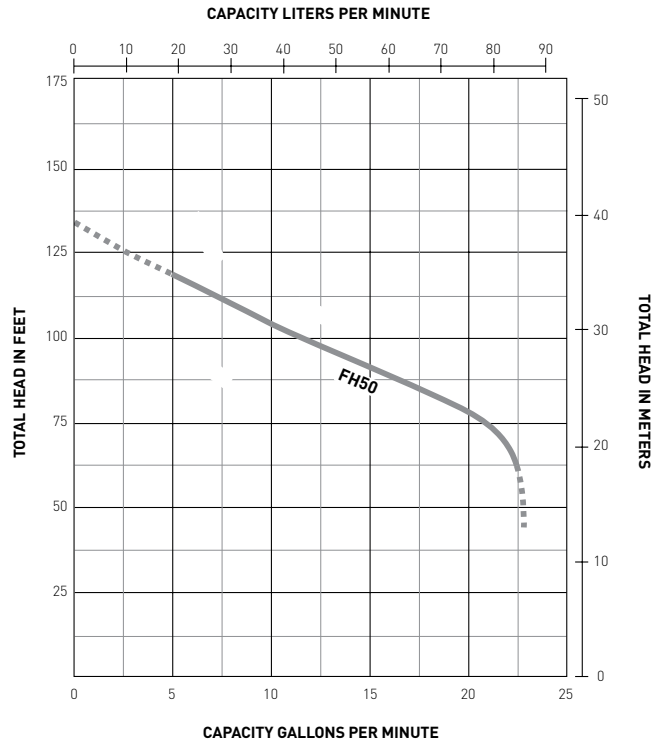

## PUMP PERFORMANCE

HP	Catalog Number	Total Suction Lift - Ft.	Discharge Pressure - PSI									Shut Off PSI
			20	25	30	35	40	45	50	55	60	
1/2	FH50	5	22.5	22.4	22.0	20.6	16.4	12.0	8.0	4.4	—	61.0
		10	19.5	19.3	19.0	17.8	14.5	10.4	6.5	2.8	—	58.8
		15	16.6	16.3	16.0	15.3	13.3	9.0	5.2	1.4	—	56.7
		20	14.0	13.8	13.6	13.2	11.4	7.3	3.5	—	—	54.5
		25	11.4	11.4	11.3	11.2	9.8	5.8	2.0	—	—	52.4

Pumping capacities in gallons per minute at indicated discharge pressures in pounds per square inch.



293 WRIGHT STREET, DELAVAN, WI 53115 WWW.STA-RITE.COM PH: 888-782-7483 ORDERS FAX: 800-426-9446  
 490 PINEBUSH ROAD, UNIT 4, CAMBRIDGE, ONTARIO, CANADA N1T 0A5 PH: 800-363-7867 ORDERS FAX: 888-606-5484  
 Because we are continuously improving our products and services, Pentair reserves the right to change specifications without prior notice.