

STA-RITE® Intelliboost® R Series

Multi-stage variable frequency drive booster pump



The Sta-Rite® Intelliboost® is the only TRUE variable speed booster with an LCD screen that gives you an easy to use, all-in-one solution for not only boosting, but also delivering a constant pressure throughout the system. This dependable unit quickly enhances your customer's system with smart controls that adjusts to their water usage.

APPLICATIONS

- Residential Boosting
- Water Transfer
- Turf Irrigation

SPECIFICATIONS

Pump Case: Stainless Steel

Diffuser: Reinforced Polypropylene

Impeller: Reinforced Polypropylene

Mechanical Shaft Seal: Carbon, Ceramic, Stainless Steel

Mounting Base: Steel

FEATURES

TRUE Variable Speed: The Intelliboost features a variable speed control that adjusts itself as demand changes to hold water pressure (up to 60psi) at the desired level.

All-In-One Unit: Includes pump, variable speed drive and tank all in one unit for quick and easy install.

Simple Startup: Unit is preset to boost 60psi, allowing you to plumb it, wire it, power up and go!

Built-in Check Valve: Includes a check valve after the discharge to further protect your system.

LCD Screen: No blinking lights! The Intelliboost has an easy-to-read LCD screen that tells you the status of your unit in plain text.

ORDERING INFORMATION

Catalog Number	HP	Input Voltage	Phase	Pipe Tapping Size		Approx. Wt. Lbs.
				Suction	Discharge	
MIB0715S	3/4	230	1	1"	1"	30

STA-RITE® Intelliboost® R Series

Multi-stage variable frequency drive booster pump

PUMP PERFORMANCE

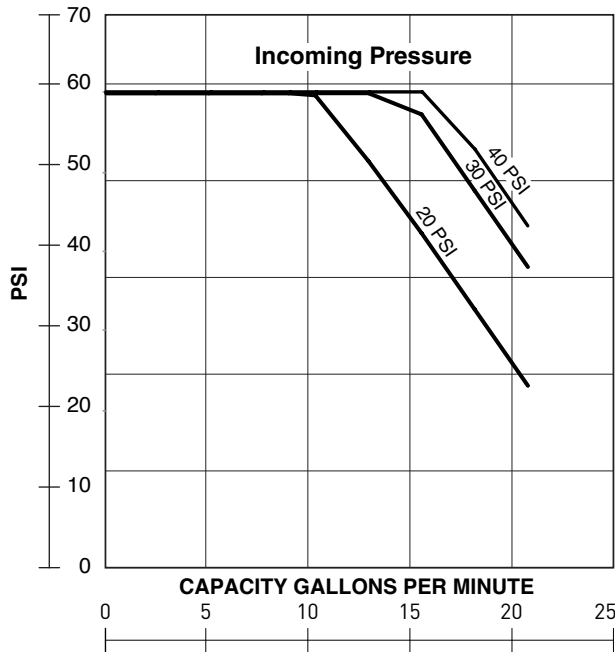

Incoming Household Pressure	Booster Set At:	
	50 PSI	60 PSI
20 PSI	Boosted Household Pressure	
	50 PSI	60 PSI
	Household Water Usage	
	Up to 13 GPM	Up to 10 GPM
30 PSI	Boosted Household Pressure	
	50 PSI	60 PSI
	Household Water Usage	
	Up to 19 GPM	Up to 15 GPM
40 PSI	Boosted Household Pressure	
	50 PSI	60 PSI
	Household Water Usage	
	Up to 21 GPM	Up to 19 GPM

OUTLINE DIMENSIONS

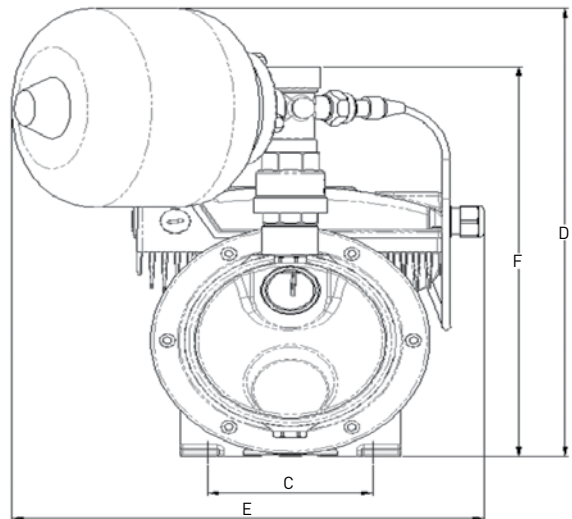
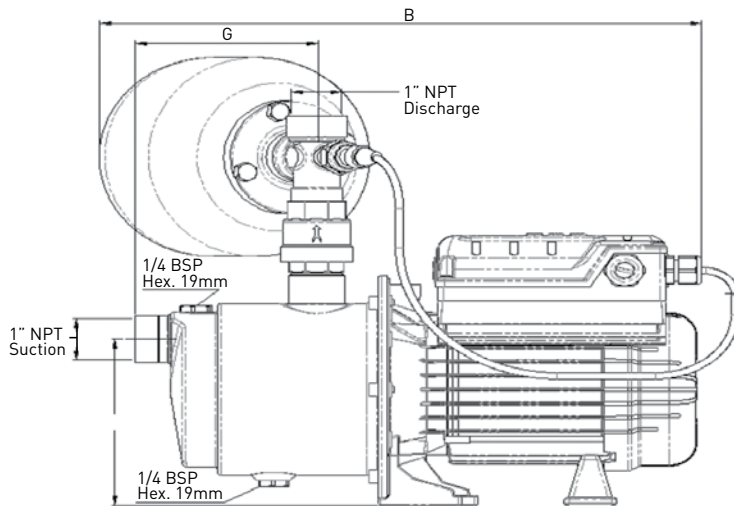

Dimensions (inch)

A	B	C	D	E	F	G
5.1	15.0	3.9	13.7	11.8	12.0	4.6



US: 293 WRIGHT STREET, DELAVAN, WI 53115 WWW.STA-RITE.COM PH: 888-782-7483 ORDERS FAX: 800-426-9446
 CANADA: 490 PINEBUSH ROAD, UNIT 4, CAMBRIDGE, ONTARIO N1T 0A5 PH: 800-363-7867 ORDERS FAX: 888-606-5484
 Because we are continuously improving our products and services, Pentair reserves the right to change specifications without prior notice.