

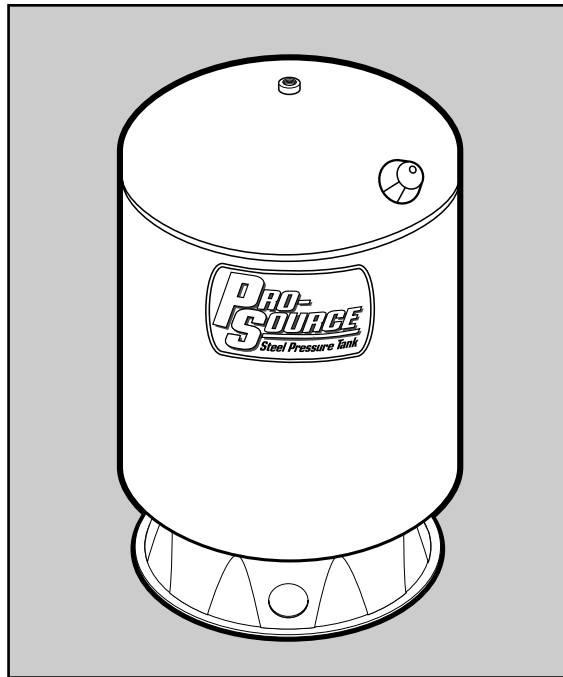

293 Wright Street  
Delavan, WI 53115

OWNER'S MANUAL  
**Pro-Source**  
**Steel Pressure Tanks**

---



E  
N  
G  
L  
I  
S  
H

F  
R  
A  
N  
Ç  
A  
I  
S

E  
S  
P  
A  
Ñ  
O  
L

**Installation/Operation/Parts**

*For further operating, installation,  
or maintenance assistance:*

**Call 1-262-728-5551**

### READ AND FOLLOW SAFETY INSTRUCTIONS!

**⚠** This is the safety alert symbol. When you see this symbol on your pump or in this manual, look for one of the following signal words and be alert to the potential for personal injury.

**⚠ DANGER** warns about hazards that **will** cause serious personal injury, death or major property damage if ignored.

**⚠ WARNING** warns about hazards that **can** cause serious personal injury, death or major property damage if ignored.

**⚠ CAUTION** warns about hazards that **will** or **can** cause minor personal injury or property damage if ignored.

The label **NOTICE** indicates special instructions which are important but not related to hazards.

**Carefully read and follow all safety instructions in this manual and on pump.**

Keep safety labels in good condition.

Replace missing or damaged safety labels.

### RULES FOR SAFE INSTALLATION AND OPERATION

Read the Owner's Manual and Rules for Safe Operation and Installation Instructions carefully. Failure to follow these Rules and Instructions could cause serious bodily injury and/or property damage.

Install system according to local codes.

Always test water from well for purity before using. Check your local health department for testing procedure.

Before installing or servicing your tank, BE SURE pump electric power source is disconnected.

BE SURE your pump electrical circuit is properly grounded.

Remove bleeder orifices, air volume controls or other air charging devices in existing system.

**⚠ WARNING** To prevent possible serious or fatal injury and/or damage to equipment, system pressure must be less than 100 pounds per square inch (PSI) under any circumstances. Failure to follow this instruction can result in tank blowup. If system discharge pressure can exceed 100 PSI, install a relief valve capable of passing the full pump volume at 100 PSI.

**⚠ WARNING** Hazardous pressure. Read owner's manual before attempting to install, operate, or service this tank. To avoid possible equipment failure, severe injury, and property damage, do not allow pump, tank, or piping system to freeze.

#### LIMITED WARRANTY

Sta-Rite Industries, warrants to the original consumer of the products listed below, that they will be free from defects in material and workmanship for the Warranty Period from the date of original installation or manufacture as noted.

Product	Warranty Period
Water Systems Products – jet pumps, small centrifugal pumps, submersible pumps and related accessories	<i>whichever occurs first:</i> 1 year from date of original installation, or 2 years from date of manufacture
Hydro-Flow Filters	1 year from date of purchase
Signature 2000® Fibrewound Tanks	5 years from date of original installation
Pro-Source™ Steel Pressure Tanks	5 years from date of original installation
Pro-Source™ Epoxy-Lined Tanks	3 years from date of original installation
Sump/Sewage/Effluent Products	1 year from date of original installation, or 2 years from date of manufacture

Our warranty will not apply to any product that has been subject to negligence, misapplication, improper installation or maintenance. In the event a three phase submersible motor is operated with single phase power through a phase converter, or if three-leg ambient compensated, extra-quick trip overload relays of recommended size are not used, our warranty is void.

Buyer's only remedy and Sta-Rite Industries' only duty is to repair or replace defective products (at Sta-Rite Industries' choice). Buyer agrees to pay all labor and shipping charges associated with this warranty and to request warranty service through the installing dealer as soon as a problem is discovered. If warranty service is requested more than 30 days after the Warranty Period has ended, it will not be honored.

STA-RITE INDUSTRIES SHALL NOT BE LIABLE FOR ANY CONSEQUENTIAL, INCIDENTAL, OR CONTINGENT DAMAGES WHATSOEVER.

THE FOREGOING WARRANTIES ARE EXCLUSIVE AND IN LIEU OF ALL OTHER EXPRESS WARRANTIES. IMPLIED WARRANTIES, INCLUDING BUT NOT LIMITED TO THE IMPLIED WARRANTIES OF MERCHANTABILITY AND FITNESS FOR A PARTICULAR PURPOSE, SHALL NOT EXTEND BEYOND THE WARRANTY PERIOD PROVIDED HEREIN.

Certain states do not permit the exclusion or limitation of incidental or consequential damages or the placing of limitations on the duration of an implied warranty, therefore, the limitations or exclusions herein may not apply. This warranty sets forth specific legal rights and obligations, however, additional rights may exist, which may vary from state to state.

Supersedes all previous publications.

Sta-Rite Industries, 293 Wright St., Delavan, WI 53115

**GENERAL INFORMATION**

All tanks are factory pre-charged with air to 40 pounds per square inch (PSI). When installing tank, reduce pre-charge to 2 PSI below pump cut-in pressure setting. To do this, bleed air from valve on top of tank.

**NOTICE:** Always set pre-charge with NO WATER in tank.

Check pressure frequently with an accurate tire pressure gauge until correct pressure has been reached. For correct pre-charge pressure settings, see Chart 1, below.

**CHART I**

Pressure Switch Setting	Tank Precharge (PSI)
20-40 PSI	18
30-50 PSI	28
40-60 PSI	38

**NOTICE:** Replace and tighten air valve cap if it is removed for any reason. Failure to replace air cap may allow loss of air pressure and eventually lead to tank waterlogging and bladder failure.

Pre-charged storage tanks can be connected together to increase the supply of usable water (draw-down). Two tanks of the same size will double the

supply and three tanks will triple the supply. See Figures No. 1A and 1B for typical installations of this kind.

**OPERATING CYCLE**

1. Tank nearly empty – air expands filling area above vinyl bladder (Fig. 2A).
2. Water begins to enter tank – air is compressed above bladder as it fills with water (Fig. 2B).
3. Pump-up cycle completed – air now compressed to cut off setting of pressure switch (Fig. 2C).
4. Water being drawn from tank – compressed tank air forces water out of bladder (Fig. 2D).
5. Bladder completely empty – new cycle ready to begin (Fig. 2A).

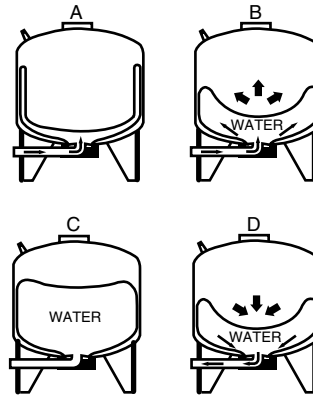

**Figure 2**

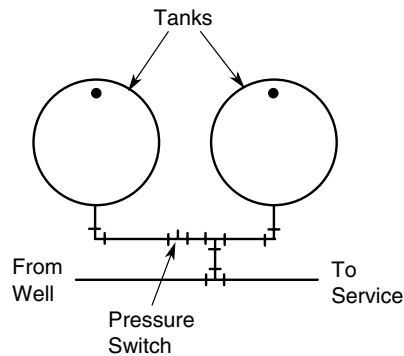

**Figure 1A**

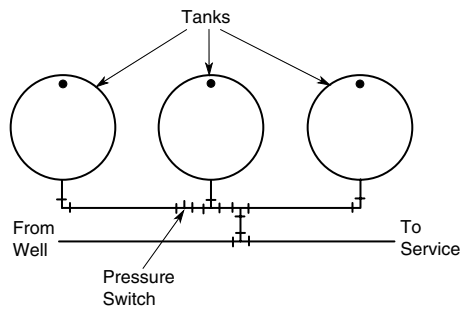

**Figure 1B**

**CHART II – Water Yield Per Pump Cycle (drawdown) in Gallons**

Model	Pressure Switch Setting (PSI)		
	20-40	30-50	40-60
PS15-S02	2.2	1.8	1.6
PS15H-S05	2.2	1.8	1.6
PS30-T01	4.8	4.1	3.6
(T)PS42S-T02	6.9	5.8	5.0
(T)PS42T-T02	6.9	5.8	5.0
(T)PS42H-S00	6.9	5.8	5.0
(T)PS75T-T03	11.6	9.8	8.5
(T)PS82T-T05	12.7	10.7	9.3
(T)PS120-T50	18.3	15.5	13.4
(T)PS200-T51	21.4	18.3	16.0
(T)PS220-T52	30.0	26.0	22.0
(T)PS320-TR50	41.3	35.4	31.0

Connect system pipe to tank flange. Use plastic or steel pipe as required. To prevent leaks, use Teflon tape or Plasto-Joint Stik<sup>1</sup> on male threads of all threaded connections to tank.

**NOTICE:** To be sure that joint is not cross-threaded and that threads are clean, always make connections by hand (without sealer) first. After making sure that threads are clean, remove pipe, add Teflon tape or Plasto-Joint Stik, and remake connection. Tighten by hand first; finish with pipe wrench for tight seal.

**NOTICE:** When replacing a standard tank in a submersible pump system, raise pump and discharge pipe far enough to remove bleeder orifices in discharge pipe and plug tees. When replacing a standard tank in a jet pump system, remove Air Volume Control (AVC) and plug AVC port in pump.

In areas where the temperature is high for long periods of time, the tank pre-charge pressure may increase. This may reduce the tank drawdown (amount of water available per cycle). If this occurs, reduce the pre-charge pressure to two PSI below the pump cut-in setting of the pressure switch.

It is necessary to flush all air out of the piping system and water reservoir portion of the pre-charged tank. This is required on new installations, pumps requiring repriming and pumps that have been disassembled for service. Do this as follows:

1. Open faucets furthest from tank and allow pump to operate.
2. Air in the system will cause a sputtering flow; allow faucets to run until you have a steady, air free stream.
3. Open and close faucets repeatedly until you are sure all air has been removed.
4. If stream does not become steady, air may be leaking into the system; check for leaks in the piping on the suction side of the pump.

<sup>1</sup>Lake Chemical Co., Chicago, Illinois

### TO CHECK TANK AIR CHARGE

If drawdown (amount of water that comes out of tank per pump cycle) decreases significantly, check as follows:

1. To check air charge in tank, shut off electric power to pump, open faucet near tank, and drain completely.
2. At the air valve in top of tank, check air pressure with a standard tire gauge. Air pressure should be 2 PSI below pump pressure switch cut-in setting.
3. If the air pressure is more than 2 PSI below the cut-in setting, add air to the tank. Use an air compressor or a portable air storage tank.
4. Use soap or liquid detergent to check for air leaks around air valve. Continuous bubbling indicates a leak. If necessary, install new core in air valve. This is the same as those used for automobile tubeless tires.

### TO CHECK PUMP PRESSURE SWITCH SETTING

1. To check pressure switch setting, disconnect power to pump at supply panel (but be sure to leave pressure switch connected to power supply wires).
2. Remove pressure switch cover.
3. Open a faucet near tank.
4. Bleed pressure down until pressure switch contacts close; immediately close faucet.
5. Check pressure at valve with standard tire gauge or with pump pressure gauge (if supplied).
6. Pressure gauge should read 2 PSI below pump cut-in setting (28 PSI for 30-50 switch, 18 PSI for 20-40 switch, etc.) If not:
  - A. Adjust switch according to switch manufacturer's instructions.

## SPECIFICATIONS

Model	Maximum Capacity U.S. Gallons	Tank Diameter	Tank Height	Tank Discharge Tapping
PS15-S02	6	12"	16-1/8"	3/4"
PS15H-S05	6	12"	16-1/8"*	3/4"
PS30-T01	14	16"	22-1/4"	1"
(T)PS42S-T02	19	20"	22"	1"
(T)PS42T-T02	19	16"	27-1/2"	1"
(T)PS42H-S00	19	16"	24-5/8"*	1"
(T)PS75T-T03	32	16"	42-3/4"	1"
(T)PS82T-T05	35	20"	32-3/4"	1"
(T)PS120T-T50	50	24"	32-1/2"	1-1/4"
(T)PS200-T51	62	24"	39-1/8"	1-1/4"
(T)PS220-T52	85	24"	50-1/2"	1-1/4"
(T)PS320-TR50	119	24"	68"	1-1/4"

\* Tank length if Model No. has "H" suffix.

- B. Reconnect power supply to pump and pump up pressure in system.
  - C. Disconnect power supply to pump again and re-check switch setting.
  - D. Repeat until pressure switch starts pump within  $\pm 1$  PSI of proper setting.
  - E. If cut-in setting is too low, system will rattle or develop water hammer when pump starts.
  - F. Cut-out setting is not as critical as cut-in setting. Make sure that pump will stop running in a reasonable time. If it does not, cut-out setting may need to be adjusted down slightly. Be sure that after readjustment, system does not rattle or hammer on startup.
7. Re-check tank air pre-charge to be sure it is 2 PSI below pump pressure switch cut-in setting (see Page 3).

**TESTING FOR BLADDER LEAKAGE**

1. **Disconnect power to pump.**
2. Drain all water from tank bladder by opening faucet closest to tank.
3. Remove valve cap from valve and release all pressure possible by depressing valve core. When air stops coming from valve, remove valve core to release remaining pressure.
4. Disconnect piping from elbow on tank flange.
5. Carefully turn tank upside down or lay it on its side.

**⚠ WARNING** Retained water in tank may cause sudden weight shift when lowering. Support tank so that it cannot fall when being lowered or inverted.

6. If bladder leaks, water will run out of valve. If so, replace bladder.

**BLADDER REPLACEMENT**

**⚠ CAUTION** To be sure cover flange cannot blow off of tank, release all air from system before removing nuts from cover flange.

1. Disconnect power to pump.
2. Follow steps 2 through 5 under “Testing For Bladder Leakage”, above.
3. Remove nuts from tank cover flange. Tap cover flange to break seal and remove.
4. Bladder will not come out in one piece. Hold bladder with pliers and cut wherever convenient with single edge razor blade or sharp knife. Continue holding and cutting until bladder is removed.
5. Clean and dry inside of tank.
6. Before bladder can be inserted into tank, it must be tightly rolled up as follows:
  - A. Place bladder on clean surface with opening to one end and flatten to force air out. Pull ends out flat (see Figure 3).

Pull ends out flat

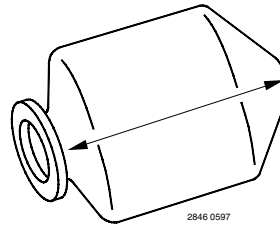

**Figure 3 – Force all air out of bladder**

- B. To get tightest possible wrap, start on one side at top and **TIGHTLY** roll bladder diagonally to other side (see Figure 4). To force out as much air as possible, be sure to roll toward bladder neck opening.

Roll Diagonally

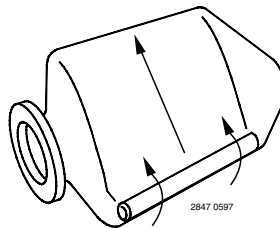

**Figure 4 – Roll diagonally toward neck**

7. To help insert bladder, sprinkle outside of it with talcum powder. With tank on its side, push tightly rolled bladder into tank, hooking bladder neck ring over edge of tank head.
  8. Insert arm in bladder and push sidewalls outward. It is not necessary to remove all wrinkles from bladder.
- NOTICE:** Don't push bladder into tank further than its own length. In a large tank, bladder can slip out of reach if pushed too far.
9. Clean tank head sealing surface and lip ring groove of cover flange.
  10. Pull lip ring of bladder through tank opening and seat it against tank head.
  11. Clean sealing surface and groove of cover flange; place on tank (see Figure 5).

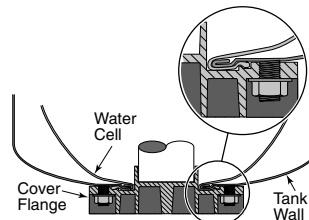

**Figure 5 – Proper installation and seating**

**NOTICE:** Be sure discharge port lines up with hole in base.

12. **NOTICE: Tighten nuts as follows:**

- A. Hand tighten all nuts.
- B. Tighten one nut snug.
- C. Tighten opposite nut snug.
- D. Proceed, tightening opposite pairs of nuts to a snug fit.
- E. Recheck all nuts, using same pattern. Be sure all nuts are tight and that you have a good seal.

**NOTICE:** Do not overtighten; you may twist studs off of tank. If you have a torque wrench, tighten to 85 inch-pounds torque.

- 13. Stand tank on feet and reconnect piping.
- 14. Recharge tank to proper air pressure (see Page 4).
- 15. Prime pump (see pump owner's manual).

**AIR VALVE REPLACEMENT**

**▲ WARNING Hazardous Pressure.** To be sure air valve and core cannot blow out of tank, release all air pressure from tank before removing valve core or valve.

- 1. Disconnect power to pump.
- 2. Drain ALL water in system by opening faucet closest to tank.
- 3. Depress valve core to release ALL air pressure in tank. When air stops coming out of valve, remove core from inside of valve to release remaining pressure.
- 4. Push air valve back into tank. Be sure to remove it before reassembling tank.
- 5. Disconnect piping from tank and turn it on its side.

- 6. Remove flange from tank.
- 7. Push bladder into tank far enough so that you can get into tank with a dowel rod.
- 8. Soap the outside of the new valve and mount it on the end of a piece of 1/4" or 5/16" dowel rod. Push the valve up past the bladder into its mounting hole in the top of the tank. Push it through as far as it will conveniently go; leave the valve cap on to protect the threads on the valve.
- 9. Rap the end of the dowel sharply with a hammer to drive the valve into position. Be sure the shoulder on the valve seats against the tank head (the ridge around the valve body should be all the way through the hole in the tank head – see Figure 6).

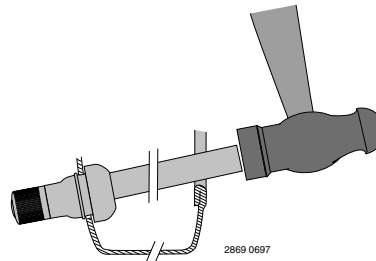

Figure 6 – Tap valve into place

- 10. Remove the dowel. Make sure the old valve has been removed from the tank, pull bladder back over rim of hole in lower tank head, reinstall flange, stand tank upright and reconnect piping.
- 11. Recharge tank (see Page 4), turn on power, fill system, and tank is ready for service.

**PIPING CONNECTIONS  
SUBMERSIBLE AND MULTI-STAGE INSTALLATIONS**

**NOTE:** When using metal pipe with plastic fittings use only Teflon tape or Plasto-Joint Stik on male threads.

**Tank with Submersible Pump**

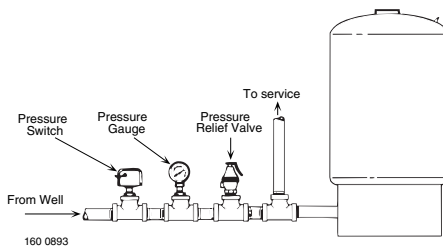

**Tank with Multi-Stage Pump**

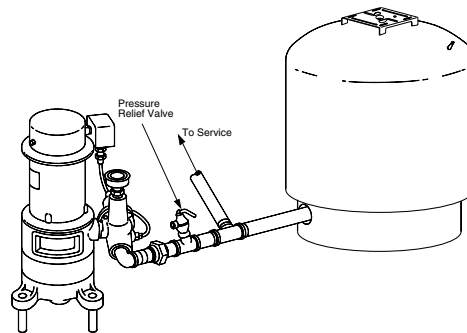

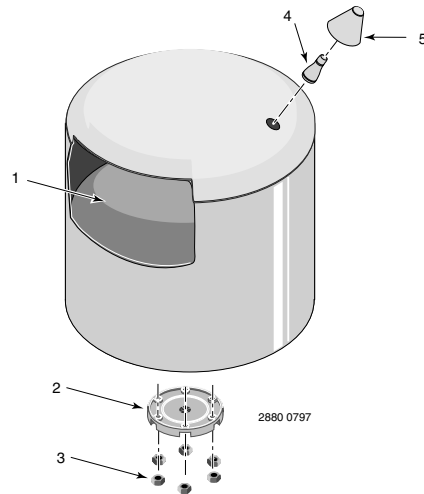

Models PS15-S02  
and PS30-T01

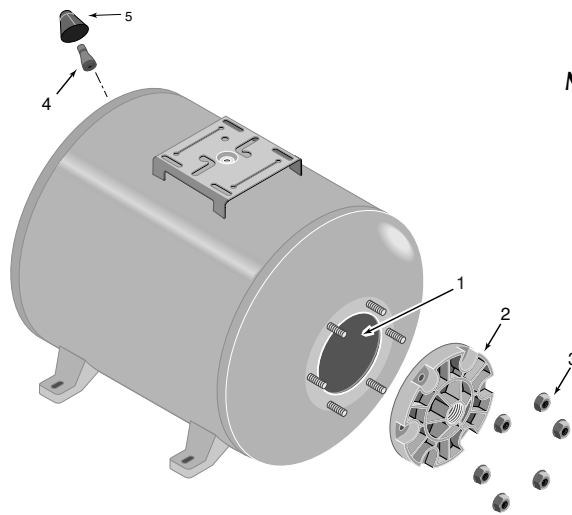

Models PS15H-S05  
and PS42H-S00

**REPAIR PARTS LIST – Pro-Source Tanks**

Key No.	Part Description	No. Used	PS15-S02 PS15H-S05 6 Gal.	PS30-T01 14 Gal.	PS42H-S00 19 Gal.
1	Bladder - Vinyl	1	U20-7	U20-13	U20-13
2	Cover Flange	1	U31-442P	U31-446P	U31-446P
3	Flanged Nut - 5/16 - 18 Hex.	6	U36-202BT	U36-202BT	U36-202BT
4	Air Valve with Cap	1	U212-160B	U212-160B	U212-160B
5	Air Valve Cover	1	U31-380P	U31-380P	U31-380P
•	Base	1	–	U31-505P	–

• Not illustrated.

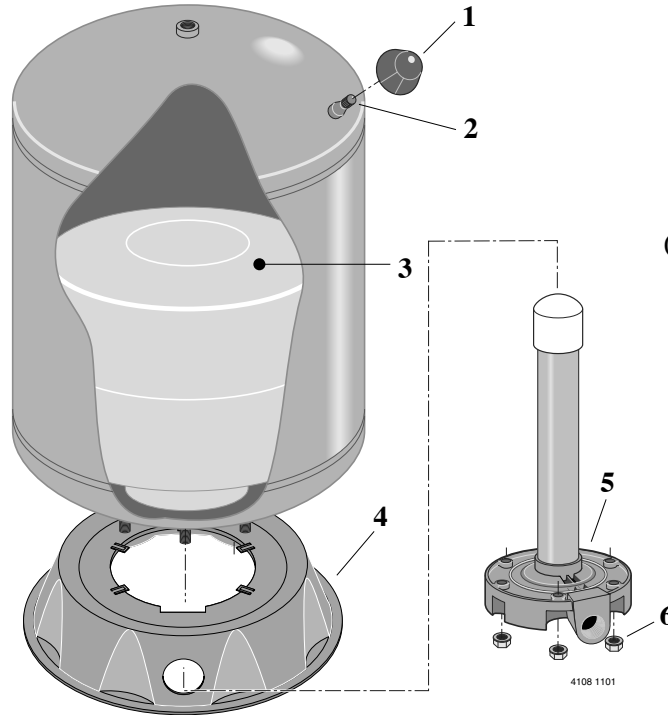

**Models**  
 (T)PS42S-T02  
 (T)PS42T-T02  
 (T)PS75T-T03  
 (T)PS82T-T05  
 (T)PS120-T50  
 (T)PS200-T51  
 (T)PS220-T52  
 (T)PS320-TR50

**REPAIR PARTS LIST – Pro-Source Tanks**

Key No.	Part Description	No. Used	(T)PS42S-T02 19 Gal.	(T)PS42T-T02 19 Gal.	(T)PS75T-T03 32 Gal.	(T)PS82T-T05 35 Gal.
1	Air Valve Cover	1	U31-380P	U31-380P	U31-380P	U31-380P
2	Air Valve with Cap	1	U212-160B	U212-160B	U212-160B	U212-160B
3	Bladder - Vinyl	1	U20-8	U20-15S	U20-15	U20-13L
4	Base	1	U31-505P	U31-505P	U31-505P	U31-505P
5	Cover Flange	1	U31-446P*	U231-460P	U231-461P	U231-460P
6	Flanged Nut 5/16 - 18 Hex	6	U36-202BT	U36-202BT	U36-202BT	U36-202BT

\* Does not require Stand Pipe.

Key No.	Part Description	No. Used	(T)PS120-T50 50 Gal.	(T)PS200-T51 62 Gal.	(T)PS220-T52 85 Gal.	(T)PS320-TR50 119 Gal.
1	Air Valve Cover	1	U31-380P	U31-380P	U31-380P	U31-380P
2	Air Valve with Cap	1	U212-160B	U212-160B	U212-160B	U212-160B
3	Bladder - Vinyl	1	U20-10	U20-14	U20-17	U20-20
4	Base	1	U31-512P	U31-512P	U31-512P	U31-512P
5	Cover Flange	1	U31-447P*	U231-482P	U231-462P	U231-462P
6	Flanged Nut 5/16 - 18 Hex	6	U36-202BT	U36-202BT	U36-202BT	U36-202BT

\* Does not require Stand Pipe.