

COMPOSITE PRESSURE TANKS

A storage home for your water needs

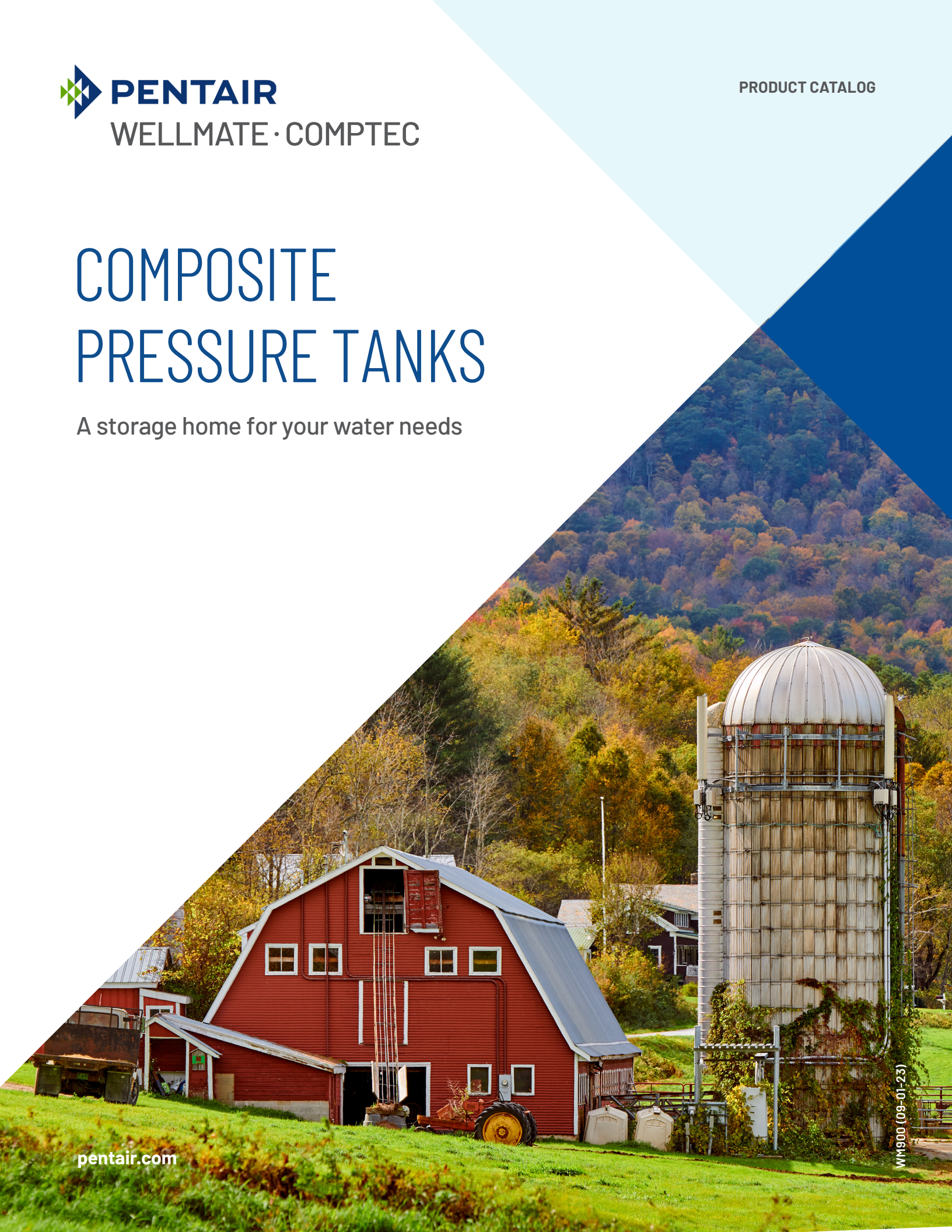

TABLE OF CONTENTS

WELLMATE PUMPS

WELLMATE OVERVIEW.....	3
WM SERIES.....	4
UT SERIES.....	6
HP SERIES.....	8
SP SERIES.....	10
E SERIES.....	11
UT/HP SERIES.....	12
HYDROPNEUMATIC APPLICATIONS.....	13

COMPTEC PUMPS

COMPTEC OVERVIEW.....	16
THREADED SERIES.....	17
FLANGED SERIES.....	18
RT SERIES.....	19
HYDROPNEUMATIC TANK SIZING.....	20
TYPICAL INSTALLATION.....	21
GENERAL SPECIFICATIONS.....	22
ASME SECTION X.....	23
DRAWDOWN FACTOR CHART.....	24

WELLMATE OFFERS DEALS WITH MORE ADVANTAGES AND MORE SOLUTIONS FOR MORE STEEL SUMP PUMP APPLICATIONS

A GROWING CUSTOMER BASE

In the residential, commercial, and agricultural markets of the world, Pentair Wellmate Composite Tanks have long been the tank of choice for their unmatched performance over steel. As the recognized leader in composite pressure tank design, Wellmate water systems give you more to sell.

With unique features that translate into real benefits for your customers, Wellmate sets you apart from the competition.

A MATERIAL DIFFERENCE

From the high-density polyethylene inner liner, to the fiberglass-wound and epoxy resin-sealed outer shell, Wellmate tanks do not contain steel, so they will not rust. What they can do is make everything easier. Wellmate tanks require little or no maintenance because they won't dent and they do not have paint to scratch and touch up. Their light weight is half that of steel tanks, making installation easier and faster.



In fact, most can be handled by a single installer, keeping costs down. Wellmate tanks are certified to NSF/ANSI std. 61 section 8 and Annex G and are 100% lead-free with NSF-372 certification. In addition, they will not introduce undesirable chemicals or elements into the water.

A PRODUCT THAT'S WORTH MORE

Innovative Wellmate solutions for water storage and pressure boosting applications offer you a world class product that's worth more. From initial design through promised delivery, quality is a hallmark of Wellmate tanks. State-of-the-art equipment, the best materials and an ISO-9001 certified manufacturing facility guarantee that our one-piece composite construction is second to none.

ONGOING DEALER SUPPORT

As a Wellmate dealer, you'll enjoy total dealer support. Wellmate tanks are only sold through a network of select professional dealers, giving you a real opportunity to make your mark. In addition, Wellmate dealers enjoy the benefits of sales training programs, seminars and technical support, as well as marketing support and dealer incentive programs. Want to know more about Wellmate and the edge it gives its dealers? Call your Wellmate distributor or visit pentair.com/wellmate for more information.



CAPTIVE AIR TANKS

WM SERIES (CLASSIC & CLASSIC QUICK CONNECT)

APPLICATIONS

Residential, light commercial, and pressure boosting.

EASY TO INSTALL, MAINTAIN, AND SERVICE

Our WM Series offers features and benefits that steel tanks can't match. From their corrosion-proof composite construction to their lighter weight, easier maintenance and less expensive installation, WM Series pressure tanks are the preferred choice of professionals, especially when the following advantages are added to the mix.

- ◆ **QUICK CONNECT** style: drain assembly, heavy gauge polymer aircell.
- ◆ **CLASSIC** style: drain assembly, heavy gauge polymer aircell. Replaceable aircell for easier field servicing.
- ◆ Easy to carry.
- ◆ Easy and less costly to install. Usually requiring only one person and fewer man-hours.
- ◆ Greater drawdown than comparably-sized steel tanks for greater efficiency.
- ◆ Won't rust in corrosive environments, which is particularly important in agricultural, livestock applications, and coastal regions.

CLASSIC QUICK CONNECT - SPECIFICATIONS

MODEL (DOMESTIC/ INTERNATIONAL)	CATALOG # (DOMESTIC/ INTERNATIONAL)	CAPACITY (GAL/LITER)	MAX OPERATING PRESSURE (PSI/KPA/BAR)	DRAWDOWN 30/50 SETTING** (GALLONS / LITERS)	SYSTEM CONNECTION (INCH/CM)	DIAMETER (INCH/CM)	OVERALL* HEIGHT (INCH/CM)	HEIGHT* FROM INLET TO FLOOR (INCH/CM)	WEIGHT * (LBS/KG)
WM-4 / WM0060 QC	CH34717 / CH34729	14.5 / 55	125 / 862 / 8.6	4.5 / 17.0	1" MNPT	16 / 41	26 / 66	1.75 / 4.4	17 / 7.7
WM-6 / WM0075 QC	34718 / CH34730	19.8 / 75	125 / 862 / 8.6	6.1 / 23.1	1" MNPT	16 / 41	32 / 81	1.75 / 4.4	21 / 9.5
WM-9 / WM0120 QC	34719 / CH34731	29.5 / 112	125 / 862 / 8.6	9.1 / 34.4	1" MNPT	16 / 41	44 / 112	1.75 / 4.4	27 / 12.2
WM-12 / WM0150 QC	34720 / CH34732	40.3 / 153	125 / 862 / 8.6	12.5 / 47.3	1" MNPT	16 / 41	57 / 145	1.75 / 4.4	37 / 16.8
WM-14WB / WM0180 QC	34721 / CH34733	47.1 / 178	125 / 862 / 8.6	14.6 / 55.3	1-1/4" MNPT	21 / 53	41.3 / 105	2.25 / 5.7	51 / 23.1
WM-20WB / WM0235 QC	CH34723 / CH34734	60.0 / 227	125 / 862 / 8.6	18.5 / 70.0	1-1/4" MNPT	24 / 61	41.5 / 105	2.25 / 5.7	61 / 27.7
WM-23 / WM0300 QC	CH34722 / CH34735	79.6 / 301	125 / 862 / 8.6	24.6 / 93.1	1-1/4" MNPT	21 / 53	62 / 157	2.25 / 5.7	66 / 30.0
WM-25WB / WM0330 QC	34724 / CH34736	86.7 / 328	125 / 862 / 8.6	26.8 / 101.5	1-1/4" MNPT	24 / 61	55.25 / 140	2.25 / 5.7	84 / 38.1
WM-35WB / WM0450 QC	34725 / CH34737	119.7 / 453	125 / 862 / 8.6	37.0 / 140.1	1-1/4" MNPT	24 / 61	74.25 / 189	2.25 / 5.7	108 / 49.0

NOTE: Maximum external operating temperature 120°F (49°C). Maximum internal operating temperature 100°F (38°C). Minimum operating temperature 40°F (4°C).

* Diameter, height and weight may vary slightly without notice.

** In keeping with current industry standards, drawdown factors are based on Boyle's law. Actual drawdowns will vary depending upon system variables, including the accuracy and operation of the pressure switch and gauge and operating temperature of the system.

CLASSIC CONNECT - SPECIFICATIONS

MODEL (DOMESTIC/ INTERNATIONAL)	CATALOG # (DOMESTIC/ INTERNATIONAL)	CAPACITY (GAL/LITER)	MAX OPERATING PRESSURE (PSI/KPA/BAR)	DRAWDOWN 30/50 SETTING** (GALLONS/ LITERS)	SYSTEM CONNECTION (INCH/CM)	DIAMETER (INCH/CM)	OVERALL* HEIGHT (INCH/CM)	HEIGHT* FROM INLET TO FLOOR (INCH/ CM)	WEIGHT * (LBS/KG)
WM-4 / WM0060 C	CH30837 / CH31632	14.5 / 55	125 / 862 / 8.6	4.5 / 17.0	16 / 41	26 / 66	1.75 / 4.4	1" MNPT	17 / 7.7
WM-6 / WM0075 C	CH30840 / CH31633	19.8 / 75	125 / 862 / 8.6	6.1 / 23.1	16 / 41	32 / 81	1.75 / 4.4	1" MNPT	21 / 9.5
WM-9 / WM0120 C	CH30854 / CH31634	29.5 / 112	125 / 862 / 8.6	9.1 / 34.4	16 / 41	44 / 112	1.75 / 4.4	1" MNPT	27 / 12.2
WM-12 / WM0150 C	CH30866 / CH31635	40.3 / 153	125 / 862 / 8.6	12.5 / 47.3	21 / 53	57 / 145	2.25 / 5.7	1-1/4" MNPT	37 / 16.8
WM-14WB / WM0180 C	CH30951 / CH31636	47.1 / 178	125 / 862 / 8.6	14.6 / 55.3	24 / 61	41.3 / 105	2.25 / 5.7	1-1/4" MNPT	51 / 23.1
WM-20WB / WM0235 C	CH31050 / CH31637	60.0 / 227	125 / 862 / 8.6	18.5 / 70.0	24 / 61	41.5 / 105	2.25 / 5.7	1-1/4" MNPT	61 / 27.7
WM-23 / WM0300 C	CH32855 / CH33237	79.6 / 301	125 / 862 / 8.6	24.6 / 93.1	21 / 53	62 / 157	2.25 / 5.7	1-1/4" MNPT	66 / 30.0
WM-25WB / WM0330 C	CH31056 / CH31638	86.7 / 328	125 / 862 / 8.6	26.8 / 101.5	24 / 61	55.25 / 140	2.25 / 5.7	1-1/4" MNPT	84 / 38.1
WM-35WB / WM0450 C	CH31062 / CH31639	119.7 / 453	125 / 862 / 8.6	37.0 / 140.1	24 / 61	74.25 / 189	2.25 / 5.7	1-1/4" MNPT	108 / 49.0

Maximum external operating temperature 120°F (49°C). Maximum internal operating temperature 100°F (38°C). Minimum operating temperature 40°F (4°C).

* Diameter, height and weight may vary slightly without notice.

** In keeping with current industry standards, drawdown factors are based on Boyle's law. Actual drawdowns will vary depending upon system variables, including the accuracy and operation of the pressure switch and gauge and operating temperature of the system.

- 1** Durable interior air cell is fully replaceable and constructed of heavy-gauge engineered polymer.
- 2** One-piece seamless inner shell is molded of high-density polyethylene.
- 3** Outer shell is composed of continuous fiberglass strands sealed with high-grade epoxy resin.
- 4** Sturdy, molded polymeric base is corrosion- and impact-proof.
- 5A** Quick connect, bottom inlet/outlet assembly is custom molded of high-impact engineered polymer.
- 5B** Bottom inlet/outlet one-piece drain is custom molded of high-impact PVC.



UNIVERSAL RETENTION TANKS

UT SERIES

APPLICATIONS

Water treatment and hydropneumatic with purchased accessories.

DO YOU HAVE CONTACT WITH CHEMICALS, CHLORINE & HYDROGEN SULFIDE? GO WITH THE PROS AND CHOOSE UT

There's no better tank choice for water treatment than our UT-Quick Connect Series. Composite construction makes the entire line impervious to the chemicals found in aggressive water. The advantages give our UT-Quick Connect Series the kind of application versatility dealers want.

FEATURES

- ◆ Inlet/Outlet PVC Pipe Connections allows straight through T connection on bottom of tank for ease of piping.
- ◆ Blowdown Valve for easy removal of sludge from bottom of tank.
- ◆ Hydropneumatic Convertible optional air volume control assembly and micronizer allow for quick and easy tank conversion.

- 1 Standard 1" ID / 1-1/4" Quick Connect Socket.
- 2 One piece, seamless inner shell molded of premium high-density polyethylene which provides impact and corrosion resistance.
- 3 Miles of fiberglass filament covered with epoxy resin produce superior strength in a lightweight design.
- 4 Additional drain port.
- 5 Curved bottom dome design maximizes contact time and facilitates sludge removal.

1-1/4" socket inlet/outlet PVC pipe connections offer maximum application flexibility (vacuum breaker required).

QUICK CONNECTION

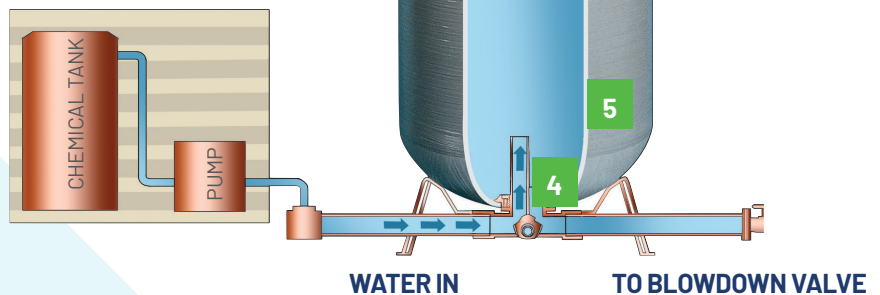
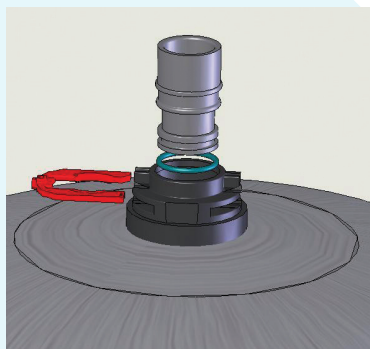

SPECIFICATIONS

MODEL (DOMESTIC/ INTERNATIONAL)	CATALOG # (DOMESTIC/ INTERNATIONAL)	CAPACITY (GAL/LITER)	MAX OPERATING PRESSURE (PSI/KPA/BAR)	DRAWDOWN 30/50 SETTING** (GALLONS/ LITERS)	SYSTEM CONNECTION (INCH/CM)	DIAMETER (INCH/CM)	OVERALL* HEIGHT (INCH/CM)	HEIGHT* FROM INLET TO FLOOR (INCH/CM)	WEIGHT * (LBS/KG)
UT-30 / WM-UT-110 CE	CH31385-1 / CH32193-1	30.0 / 114	75 / 500 / 5.0	16 / 41	46 / 116.8	1.5 / 3.8	1-1/4" Socket QC	1-1/4" Socket	23 / 10.4
UT-40 / WM-UT-150 CE	CH31301-1 / CH32194-1	40.0 / 151	75 / 500 / 5.0	16 / 41	58.7 / 149.2	1.5 / 3.8	1-1/4" Socket QC	1-1/4" Socket	31 / 14.1
UT-40SQ / WM-UT150-SQ CE	CH31433-1 / CH32195-1	40.0 / 151	75 / 500 / 5.0	21 / 53	37.5 / 95.2	2 / 5.1	1-1/4" Socket QC	1-1/4" Socket	33 / 15.1
UT-80 / WM-UT-300 CE	CH31309-1 / CH32196-1	80.0 / 303	75 / 500 / 5.0	21 / 53	64.2 / 163.2	2 / 5.1	1-1/4" Socket QC	1-1/4" Socket	53 / 24.0
UT-120 / WM-UT-450 CE	CH31312-1 / CH32197-1	120.0 / 454	75 / 500 / 5.0	24 / 61	74.3 / 188.7	2 / 5.1	1-1/4" Socket QC	1-1/4" Socket	77 / 34.9

Maximum external operating temperature 120°F (49°C). Maximum internal operating temperature 100°F (38°C). Minimum operating temperature 40°F (4°C).

*Diameter, height and weight may vary slightly without notice.

ACCESSORIES

(For hydropneumatic conversion)

PART #	PART DESCRIPTION	AIR VOLUME CONTROL ASSEMBLY PART #	TANK MODEL #
CH3929-5	Micronizer	CH20287	UT-30
CH19426	Vacuum Breaker 1/4" NPT	CH20289	UT-40
		CH20288	UT-40SQ
		CH20290	UT-80
		CH20291	UT-120

NOTE: Flexible connectors must be installed between hard piping and tank openings. These pressure vessels are rated for an internal negative pressure of 5" HG (17 Pa) vacuum below atmospheric. If negative pressure could ever exceed 5" Hg (17 Pa), an adequate vacuum breaker must also be properly installed. Failure to install flex connection properly, or improper installation of a vacuum breaker when required, may void the warranty.



Air Volume Control Assembly



Micronizer



Vacuum Breaker



Tested and Certified by the Water Quality Association (WQA) to NSF/ANSI-61, Section 8 and NSF/ANSI 372.

HYDROPNEUMATIC AIR/WATER TANKS

HP SERIES

APPLICATIONS

Sulfur and iron water treatment, hydrochloride environments, tank for water treatment, and methane or other well gas release.

TOUGHEST TANKS FOR MOST DIFFICULT INSTALLS

The HP-Quick Connect Series hydropneumatic tanks can be used for aggressive water, or as an open system where air is introduced to oxidize and aerate.

FEATURES

- ◆ Large Drawdown Ratio for increased efficiency.
- ◆ Adapter and UT Drain Assembly (sold separately) allows you to add a 1" riser pipe to increase water aeration.
- ◆ Self-Adjusting Air Volume Control for system flexibility and ease of installation.

- 1 1/4" vent line, 360° rotating thread-less connection
- 2 Top-mounted air volume control provides 50% or more drawdown than similar sized conventional tanks
- 3 Miles of fiberglass filament covered with epoxy resin produce superior strength in a light-weight design
- 4 Self-adjusting air volume control – a Pentair Wellmate exclusive
- 5 One piece, seamless inner shell molded of premium high-density polyethylene provides impact and corrosion resistance
- 6 Convex bottom design with top-mounted air volume control maximizes drawdown
- 7 1-1/4" socket inlet/outlet PVC pipe connections offer maximum application flexibility
- 8 Blowdown port with 1/2" NPT connection

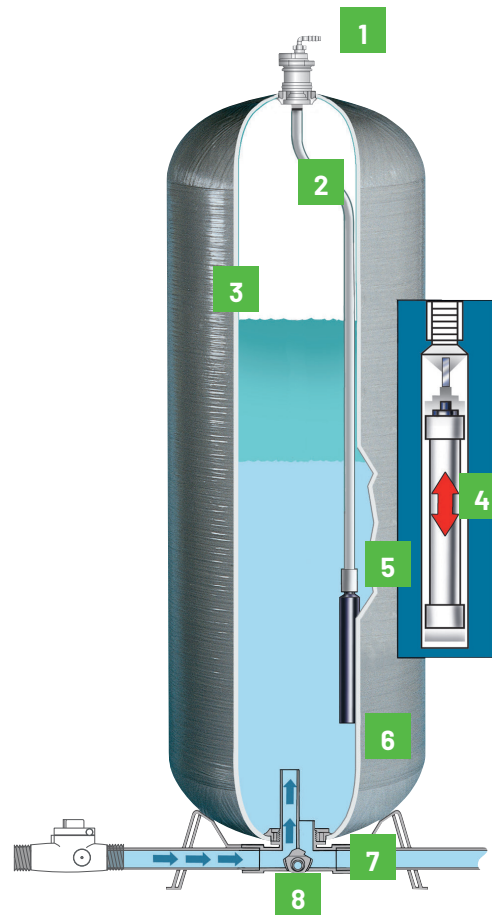

Tested and Certified by the Water Quality Association (WQA) to NSF/ANSI-61, Section 8 and NSF/ANSI 372.

SPECIFICATIONS

MODEL (DOMESTIC/ INTERNATIONAL)	CATALOG # (DOMESTIC/ INTERNATIONAL)	CAPACITY (GAL/LITER)	MAX OPERATING PRESSURE (PSI/KPA/BAR)	DRAWDOWN 30/50 SETTING** (GALLONS/ LITERS)	DIAMETER (INCH/CM)	OVERALL* HEIGHT (INCH/CM)	HEIGHT* FROM INLET TO FLOOR (INCH/CM)	SYSTEM CONNECTION (TOP)	SYSTEM CONNECTION (BOTTOM)	WEIGHT (LBS/KG)
HP-7 / WM-HP-110	CH31666-1 / CH32189-1	30.0 / 114	75 / 500 / 5.0	6.6 / 25.0	16 / 41	45.2 / 115.6	1.5 / 3.8	1/4" Vent Line	1-1/4" Socket	24 / 10.9
HP-9 / WM-HP-150	CH31667-1 / CH32199-1	40.0 / 151	75 / 500 / 5.0	9.0 / 34.1	16 / 41	58.2 / 148	1.5 / 3.8	1/4" Vent Line	1-1/4" Socket	33 / 15.1
HP-8SQ / WM-HP-150SQ	CH31735-1 / CH32190-1	40.0 / 151	75 / 500 / 5.0	8.0 / 30.3	21 / 53	37 / 94	2 / 5.1	1/4" Vent Line	1-1/4" Socket	34 / 15.4
HP-18 / WM- HP-300	CH31668-1 / CH32191-1	80.0 / 303	75 / 500 / 5.0	17.8 / 67.4	21 / 53	63.7 / 161.9	2 / 5.1	1/4" Vent Line	1-1/4" Socket	55 / 24.9
UT-120 / WM-UT-450 CE	CH31669-1 / CH32192-1	120.0 / 454	75 / 500 / 5.0	25.5 / 96.5	24 / 61	74.3 / 188.7	2 / 5.1	1/4" Vent Line	1-1/4" Socket	81 / 36.7

Maximum external operating temperature 120°F (49°C). Maximum internal operating temperature 100°F (38°C). Minimum operating temperature 40°F (4°C).

* Diameter, height and weight may vary slightly without notice.

** In keeping with current industry standards, drawdown factors are based on Boyle's law. Actual drawdowns will vary depending upon system variables, including the accuracy and operation of the pressure switch and gauge and operating temperature of the system.

PART #	PART DESCRIPTION
CH3929-5	Micronizer
CH19426	Vacuum Breaker 1/4" NPT



Micronizer



Vacuum Breaker

NOTE: Flexible connectors must be installed between hard piping and tank openings. These pressure vessels are rated for an internal negative pressure of 5" HG (17 Pa) vacuum below atmospheric. If negative pressure could ever exceed 5" Hg (17 Pa), an adequate vacuum breaker must also be properly installed. Failure to install flex connection properly, or improper installation of a vacuum breaker when required, may void the warranty.

SIDEPORT WATER TANKS

SP SERIES

APPLICATIONS

Residential and light commercial.

EASY TO INSTALL, MAINTAIN, AND SERVICE

Made of all NSF/ANSI-61 certified material, SidePort SP tanks contain no harmful traces of metal (as with steel tanks) that could pass into your water.

Our tanks are environmentally safe and 100% lead-free. Designed as a direct replacement for galvanized steel and epoxy-lined steel tanks, SidePort SP Series tanks can save you time and money.

FEATURES

- ◆ Corrosion-proof composite construction.
- ◆ UV protection – All SP tanks come with additional urethane coating for years of added protection.
- ◆ Light weight minimizes labor cost; no need for heavy equipment. No rust or corrosion means no maintenance. Long lasting, durable finish.
- ◆ Ideal for applications where high sulfur content is present and environments where methane or other well gases are present.



SPECIFICATIONS

MODEL	CATALOG #	CAPACITY (GAL/LITER)	MAX OPERATING PRESSURE (PSI/KPA/BAR)	DRAWDOWN 30/50 SETTING** (GALLONS/LITERS)	DIAMETER (INCH/CM)	OVERALL* HEIGHT (INCH/CM)	HEIGHT* FROM INLET TO FLOOR (INCH/CM)	SYSTEM CONNECTION (TOP)	SYSTEM CONNECTION (BOTTOM)	WEIGHT (LBS/KG)
SP-7	CH33020	30 / 114	100 / 700 / 7.0	7 / 26	16 / 41	43.75 / 111	1.5 / 3.8	14 / 35.6	1-1/4" Socket	26 / 11.8
SP-9	CH33021	40 / 151	100 / 700 / 7.0	9 / 34	16 / 41	56.5 / 144	1.5 / 3.8	15.5 / 39.4	1-1/4" Socket	35 / 15.9
SP-9SQ	CH33022	47 / 178	100 / 700 / 7.0	9 / 34	21 / 53	41.25 / 105	2 / 5.1	16.9 / 42.9	1-1/4" Socket	48 / 21.8
SP-18	CH33023	80 / 303	100 / 700 / 7.0	18 / 67	21 / 53	62 / 157	2 / 5.1	18.3 / 46.5	1-1/4" Socket	67 / 30.5
SP-26	CH33024	120 / 454	100 / 700 / 7.0	26 / 98	24 / 61	72.5 / 184	2 / 5.1	20.2 / 51.3	1-1/4" Socket	97 / 44.1

CAPTIVE AIR AND RETENTION TANKS

E-SERIES

APPLICATIONS

High volume water storage and water storage treatment.



FEATURES

- ◆ Retention tank capability without the air cell, can function as a high capacity retention tank for water storage and treatment.
- ◆ Heavy gauge polymer air cell offers a longer life than bladders or diaphragms (captive air tank only).
- ◆ Wider range of pressure settings for greater application versatility.
- ◆ Pre-installed inlet/outlet assembly with system connections to save time and money.
- ◆ Polyetherurethane air cell offers a longer life than bladders or diaphragms.
- ◆ Applications for high volume water storage and water storage treatment.

SPECIFICATIONS

MODEL	CATALOG #	CAPACITY (GAL/LITER)	MAX OPERATING PRESSURE (PSI/KPA/BAR)	DRAWDOWN 30/50 SETTING (GAL/LITER)**	DIAMETER (INCH/CM)	OVERALL* HEIGHT (INCH/CM)	HEIGHT* FROM INLET TO FLOOR (INCH/CM)	SYSTEM CONNECTION		WEIGHT (LBS/KG)
								TOP	BOTTOM	
CAPTIVE AIR TANK										
WM-60	CH33051	187 / 707	125 / 862 / 8.6	55.2 / 209	30 / 76	79 / 201	7.5 / 19	N/A	2" FNPT	225 / 102.1
RETENTION TANKS										
RT-200	CH33140	187 / 707	125 / 862 / 8.6	N/A	30 / 76	79 / 201	7.5 / 19	2" NPSM	2" MNPT	205 / 93
RT-270	CH33141	264 / 999	125 / 862 / 8.6	N/A	36 / 91	81 / 206	8.0 / 20	2" NPSM	2" MNPT	248 / 112.5

Maximum external operating temperature 120°F (49°C). Maximum internal operating temperature 100°F (38°C). Minimum operating temperature 40°F (4°C).

* Diameter, height and weight may vary slightly without notice.

** In keeping with current industry standards, drawdown factors are based on Boyle's law. Actual drawdowns will vary depending upon system variables, including the accuracy and operation of the pressure switch and gauge and operating temperature of the system.

AERATION TANKS

UT/HP SERIES

HOW TO AIR OUT UNDESIRABLE GASES

Got a problem with undesirable well gases? These tanks have been designed to introduce air to oxidize and aerate, minimizing or even eliminating both methane gas and hydrogen sulfide gas which is detectable by its rotten egg odor. These tough-performing tanks also offer the following:

- ◆ Large Drawdown Ratio for increased efficiency.
- ◆ Self Adjusting Air Volume Control System for flexibility and ease of installation.
- ◆ Composite Construction for increased tank life.

*Note: Pentair Wellmate does not guarantee sizing requirements or the successful removal of odors and gases. It is the responsibility of the contractor or water treatment specialist to assess the many variables involved and select the proper tank.

- 1 1/4" vent line, 360° rotating thread-less connection. Vacuum breaker required* (Refer to Note below)
- 2 Water level
- 3 Cap and pipe with 1/4" drilled holes to distribute flow. Minimum 12-17 holes required (not supplied with tank).
- 4 Riser tube of 1" pipe (not supplied w/tank)
- 5 Adapter P/N CH11068
- 6 Vacuum breaker required for HP applications
- 7 Air volume control system
- 8 Micronizer

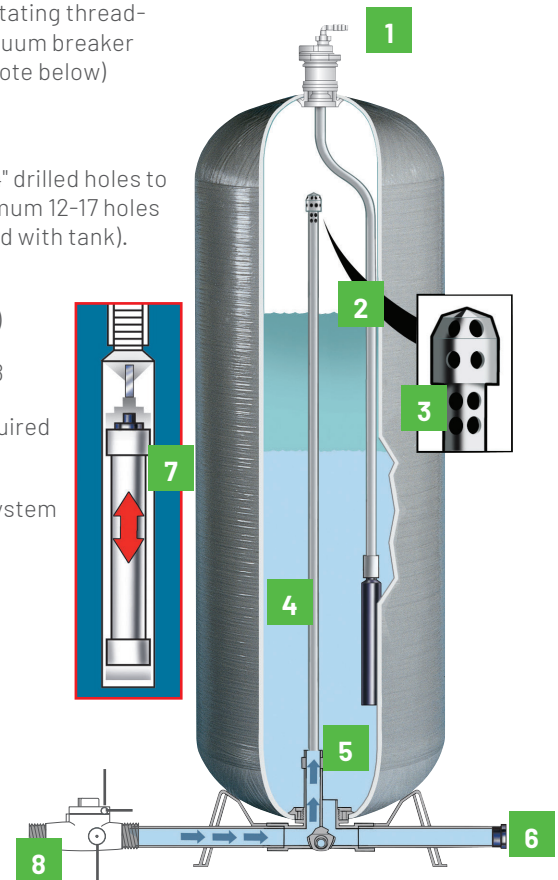

WARNING: To avoid health or environmental hazards from gas accumulation, plumb the top fitting to vent off gas to a safe area.

SPECIFICATIONS

QUICK CONNECT MODEL	CAPACITY (GAL/LITER)	1" RISER TUBE LENGTH (INCHES)	1/2 AVC (TUBE ONLY) (INCHES)	AVC OVERALL LENGTH (INCHES)
UT-30 / HP-7	30 / 114	24.00	23.25	34.88
UT-40SQ / HP-8SQ	40 / 151	16.00	14.50	26.15
UT-40 / HP-9	40 / 151	37.50	35.50	47.12
UT-80 / HP-18	80 / 303	42.75	40.00	51.62
UT-120 / HP-26	120 / 454	53.00	46.50	58.12

ACCESSORIES

PART #	PART DESCRIPTION
CH3929-5	Micronizer
CH19426	Vacuum Breaker 1/4" NPT
CH11068	Adapter



Tested and Certified by the Water Quality Association (WQA) to NSF/ANSI-61, Section 8 and NSF/ANSI 372.

Maximum external operating temperature 120°F (49°C). Maximum internal operating temperature 100°F (38°C). Minimum operating temperature 40°F (4°C).

Diameter, height and weight may vary slightly without notice.

In keeping with current industry standards, drawdown factors are based on Boyle's law. Actual drawdowns will vary depending upon system variables, including the accuracy and operation of the pressure switch and gauge and operating temperature of the system.

Flexible connectors must be installed between hard piping and tank openings. These pressure vessels are rated for an internal negative pressure of 5" HG (17 Pa) vacuum below atmospheric. If negative pressure could ever exceed 5" Hg (17 Pa), an adequate vacuum breaker must also be properly installed. Failure to install flex connection properly, or improper installation of a vacuum breaker when required, may void the warranty.

TWO COMMON HYDROPNEUMATIC APPLICATIONS

Tank Sizing Information

There are three factors to consider when selecting the proper size Wellmate tank for your water system:

- ◆ The pump delivery rate in gallons/liters per minute (GPM/LPM).
- ◆ The recommended minimum running time of the pump.
- ◆ The minimum (cut-in) and maximum (cut-out) system pressure parameters.

Once these factors are known, the following calculations will determine, in most cases, the correct model to meet your specifications.

Calculating Drawdown

1. Pump delivery rate. _____ GPM/LPM
2. Desired minimum pump running time in minutes
(1 minute, 45 seconds = 1.75 min). _____ Minutes
3. Multiply line #1 by line #2. This is the minimum drawdown or available water volume required.* _____ Gallons/Liters

Calculating Tank Size

1. Minimum system pressure (cut-in). _____ PSIG/kPa/BAR
2. Maximum system pressure (cut-out). _____ PSIG/kPa/BAR
3. Using the Drawdown Factor Table, find the drawdown factor applicable to lines #4 and #5. _____ Factor
4. Divide line #3 by line #6 to determine the minimum total Wellmate volume required. _____ Gallons/Liters
5. Refer to the design data and select the Wellmate model with the lowest total capacity that is greater than or equal to line #7. _____ Model

Example: An application using an 8 GPM pump with a minimum run time of 1 minute and a 30-50 PSIG system pressure range:

$$\frac{8 \text{ GPM} \times 1 \text{ minute}}{.30 \text{ (factor)}} = 26.7 \text{ gallon minimum tank capacity}$$

* If the volume of water needed is greater than the amount calculated on line #3, enter that amount on line #3 in place of the calculated volume.

COMPOSITE PRESSURE TANK CATALOG

TWO COMMON HYDROPNEUMATIC APPLICATIONS

SHALLOW WELL OR PRESSURE BOOSTING SYSTEM

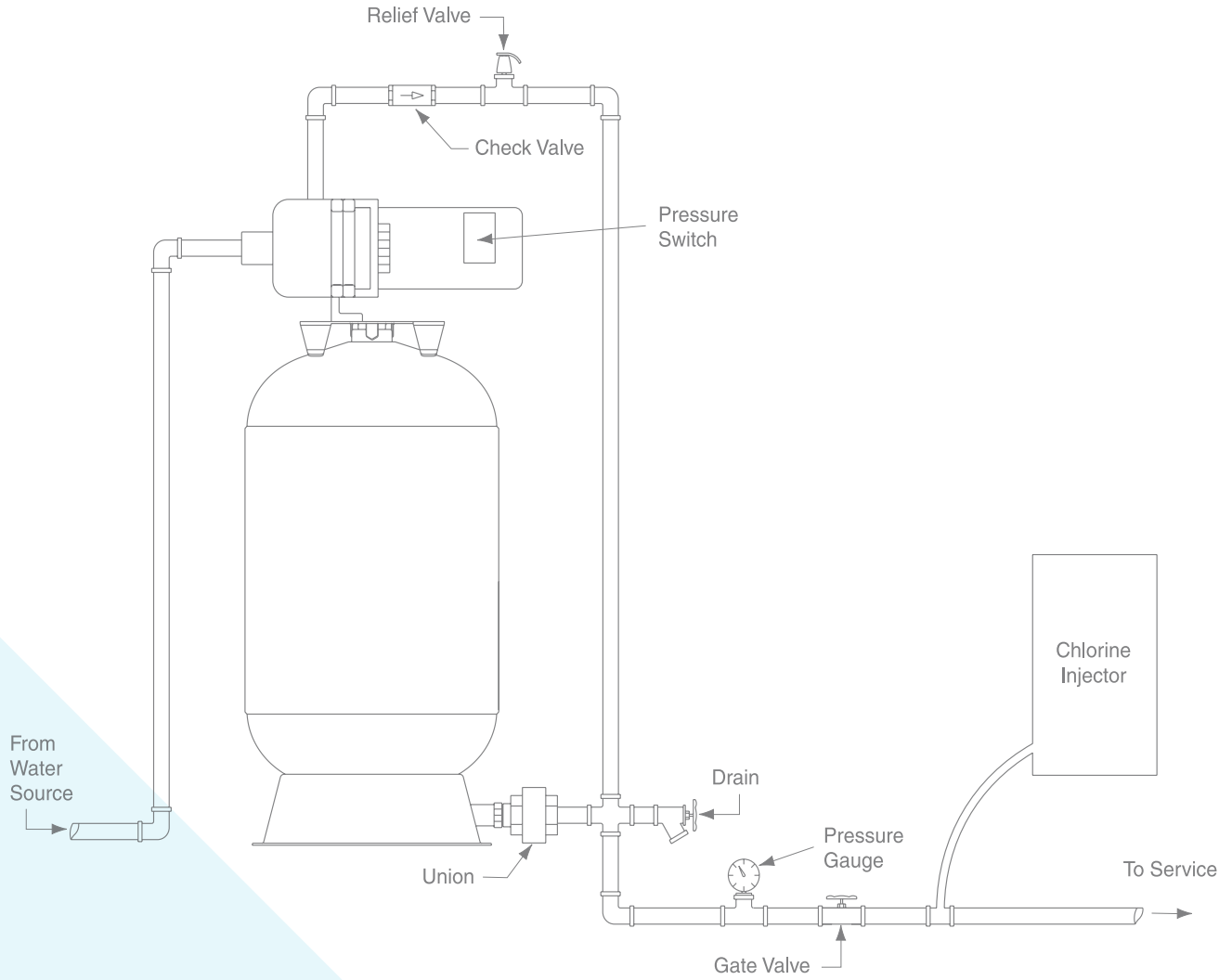

DEEP WELL SYSTEM

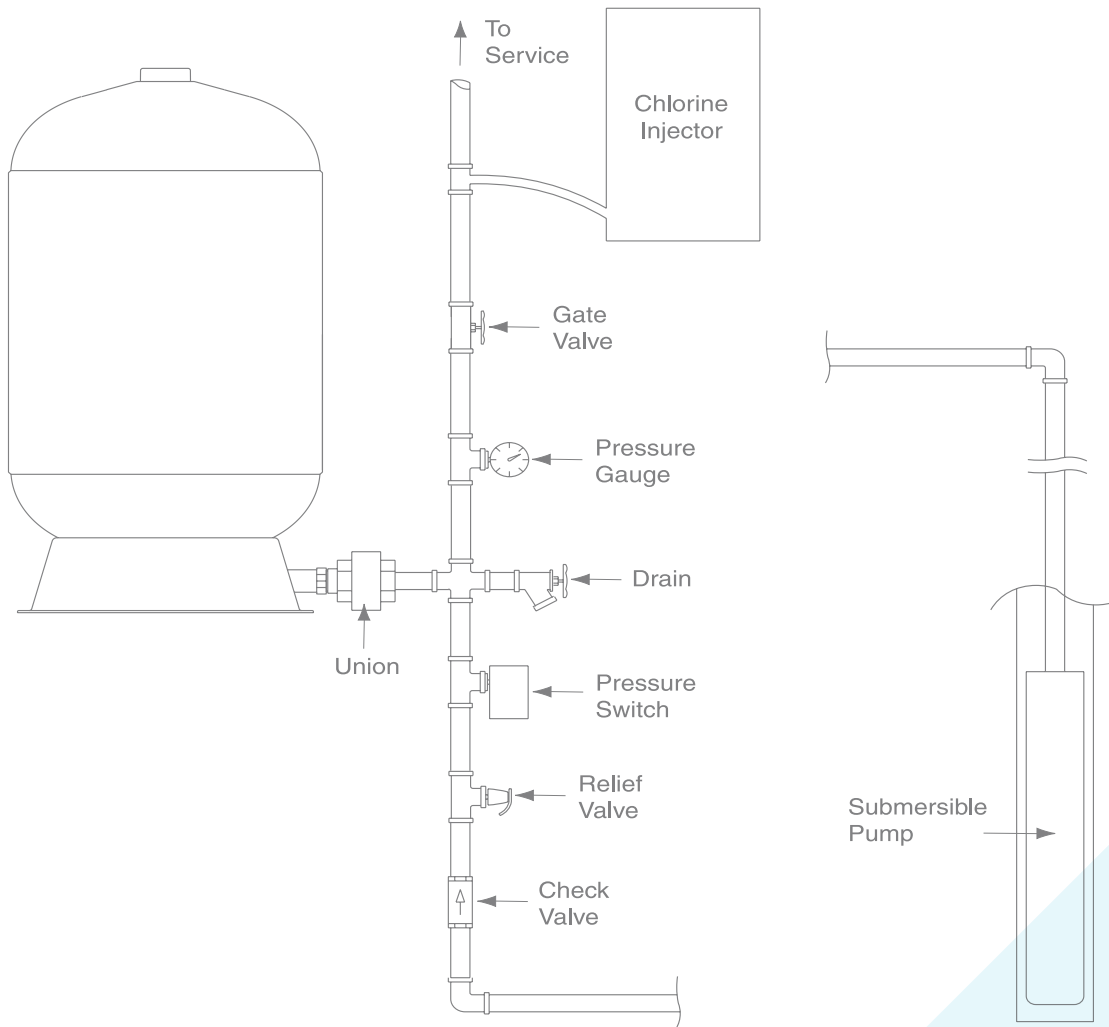

COMPTEC COMPOSITE WATER SYSTEM PRESSURE TANKS

HIGH PERFORMANCE AT THE LOWEST LIFE CYCLE COST FOR COMMERCIAL AND INDUSTRIAL APPLICATIONS

Over forty years of industry-leading experience go into the design and manufacture of Pentair Comptec commercial and industrial pressure tanks. Advanced composite construction and the resulting lower life cycle costs are what make Comptec tanks superior to steel.

Our line of pressure tanks are engineered to provide maximum performance when high volume water storage or higher system pressures are needed.



Less costly to install – Advanced composite materials result in tanks that are as strong as steel while weighing up to half as much, making handling and installing Comptec tanks are much simpler. In fact, they don't even require cranes or other heavy equipment to install, reducing labor and costs. You'll even realize substantial freight savings compared to steel tanks.

No maintenance – Comptec Tanks are constructed of fiberglass and engineered polymers so rust does not develop. Unlike steel tanks, they require no painting or relining, and are not subject to pin holes. Less required maintenance over the life of the tank results in lower life cycle costs.

Easy field service – Steel tanks frequently need to be removed from the service location to be repaired; not so with Comptec. The replaceable aircell and fittings can be changed on site, reducing downtime and labor costs.

High performance with a reduced life cycle cost for commercial and industrial applications – In addition to their cost-saving benefits, Comptec Tanks contain no metals that can leach lead or other harmful elements into the water.

Fast and efficient delivery – Our state-of-the-art manufacturing facility ensures delivery of the products you need when and where you need them.

It all adds up to the best performance at a reduced life cycle cost – Comptec Tanks are worth more than steel tanks. You get value-added features that make them easier to install, and far less costly to maintain. These benefits add up to an installed product that performs better than steel, at a reduced life cycle cost.



Available in a multiple of sizes and pressures to best suit your needs.



Experience reduced lifecycle costs with our composite construction which eliminates rusting over time.

THREADED SERIES COMPOSITE PRESSURE TANKS

MODELS CPV-47T, CPV-62T, CPV-87T, CPV-119T, CPV-160T, CPV-185T

LIGHTER, TOUGHER, STRONGER

Just as strong as steel at up to half the weight, Pentair CompTec composite hydropneumatic pressure vessels outperform steel in a wide range of performance tests including burst pressure and the ratio of strength-to-weight.

Plus, their replaceable aircell and fittings can be changed on site, reducing downtime and labor costs.

- ◆ Available in sizes that range from a 47 to 195-gallon capacity. Our threaded vessels are rated at 150 psig while ASME vessels are rated at 125 psig.
- ◆ Maintains system pressure when the pump is not operating.
- ◆ Reduces system cycling time
- ◆ Increases pump and water system life
- ◆ Large drawdown prevents pumps from over-cycling, saving energy by reducing frequent pump starts
- ◆ Large acceptance volume helps the pump meet peak demands
- ◆ Permanent separation of air and water
- ◆ Factory pre-charged and field adjustable
- ◆ Can be manifolded for additional capacity

APPLICATIONS

- ◆ Pressurized water storage for community wells
- ◆ High rise buildings and irrigation systems
- ◆ Pressure boosting

OPERATING SPECIFICATIONS

- ◆ Maximum operating pressure - 150 psig / 10 bar (non-code)
- ◆ Maximum operating pressure - 125 psig / 8.6 bar (code)
- ◆ Maximum operating temperature - 120° F / 50° C (code / non-code)

FEATURES

- 1 Aircell provides permanent separation of air and water, and allows maximum drawdown efficiency. Wide pressure switch settings are possible with virtually no maximum acceptance factor limits. Aircell is replaceable at the site of installation.
- 2 One piece, seamless inner shell molded of premium polyethylene provides impact and corrosion resistance.
- 3 Outer shell is constructed of continuous fiberglass strands sealed with high grade epoxy resin.
- 4 Corrosion-resistant base allows easy access to bottom connection for installation and field service.
- 5 Stainless steel connection is both tough and corrosion resistant.

ASME Section X construction available for select models.

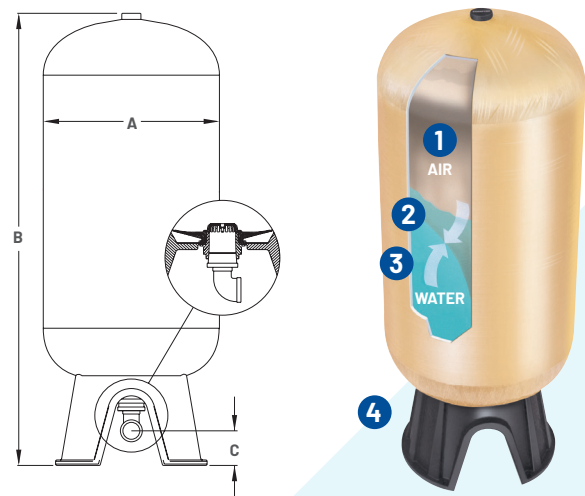

MODEL	CATALOG #	TANK CAPACITY GAL/LITER	DIAMETER A INCH/CM	HEIGHT B INCH/CM	SYSTEM CONNECTION	CONNECTION HEIGHT C INCH/CM	WEIGHT LBS/KG
CPV-47T	CH32115	47/178	21/53	49/124.5	2" NPT	5/13	78/35.4
CPV-62T	CH32107	62/235	24/61	49/124.5	2" NPT	5/13	96/43.5
CPV-87T	CH32091	87/329	24/61	63/160	2" NPT	5/13	134/60.8
CPV-119T	CH32092	119/450	24/61	82/208.3	2" NPT	5/13	160/72.6
CPV-160T	CH32177	160/606	30/76	75/190.5	2" NPT	7/18	389/176.4
CPV-185T	CH32149	185/700	30/76	90/228.6	2" NPT	7/18	453/205.5

Note: All dimensions are ±1".

FLANGED SERIES COMPOSITE PRESSURE TANKS

MODELS CPV-120F, CPV-185F, CPV-245F, CPV-340F, CPV-460F

BUILT FOR A LOW LIFE CYCLE COST

When it comes to vessels for commercial, industrial, and municipal well water and booster applications, don't follow the standards. Set them.

Pentair CompTec composite hydropneumatic pressure vessels require no heavy equipment for installation. No painting or relining. No servicing off site. Constructed so rust does not develop.

Available in sizes that range from a 120 to 460-gallon capacity, our flanged vessels are rated at 150 psig.

- ◆ Maintains system pressure when the pump is not operating.
- ◆ Reduces system cycling time
- ◆ Increases pump and water system life
- ◆ Large drawdown prevents pumps from over-cycling, saving energy by reducing frequent pump starts
- ◆ Large acceptance volume helps the pump meet peak demands

APPLICATIONS

- ◆ Commercial
- ◆ Industrial
- ◆ Municipal well water
- ◆ Booster applications



OPERATING SPECIFICATIONS

- ◆ Maximum operating pressure - 150 psig / 10 bar
- ◆ Maximum operating temperature - 120° F / 50° C

FEATURES

- 1 Aircell provides permanent separation of air and water, and allows maximum drawdown efficiency. Wide pressure switch settings are possible with virtually no maximum acceptance factor limits. Aircell is replaceable at the site of installation.
- 2 One piece, seamless inner shell molded of premium polyethylene provides impact and corrosion resistance.
- 3 Outer shell is constructed of continuous fiberglass strands sealed with high grade epoxy resin.
- 4 Corrosion-resistant base allows easy access to bottom connection for installation and field service.
- 5 Stainless steel connection is both tough and corrosion resistant.

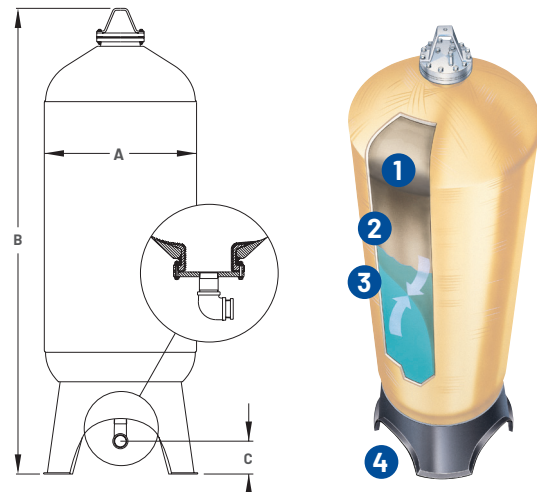

MODEL	CATALOG #	TANK CAPACITY GAL/LITER	DIAMETER A INCH/CM	HEIGHT B INCH/CM	SYSTEM CONNECTION	CONNECTION HEIGHT C INCH/CM	WEIGHT LBS/KG
CPV-120F	CH32044	120/454	24/61	94/239	2" NPT	9/23	316/143.3
CPV-185F	CH32045	185/700	30/76	92/234	2" NPT	6½/17	383/173.7
CPV-245F	CH32046	245/927	36/91	94/239	3" NPT	8/20	466/211.4
CPV-340F	CH32047	340/1287	42/107	91/231	3" NPT	8/20	682/309.7
CPV-460F	CH32048	460/1741	48/122	96/244	3" NPT	8½/22	750/340.2

Note: All dimensions are ±1".

RT SERIES COMPOSITE RETENTION TANKS

MODELS RT-120F, RT-185F, RT-245F, RT-340F, RT-460F

THE VESSEL OF CHOICE FOR CHEMICAL CONTACT

Pentair Comptec Retention Tanks are constructed of fiberglass and engineered polymers – substances which are immune to many corrosive chemicals. This makes them the ideal choice for commercial, industrial and municipal water treatment applications where contact time is required to kill bacteria.

Available in sizes that range from a 120 to 460-gallon capacity, our RT flanged vessels are rated at 150 psig. They can also be manifolded for additional capacity.



FEATURES

- 1 One piece, seamless inner shell molded of premium polyethylene provides impact and corrosion resistance.
- 2 Outer shell is constructed of continuous fiberglass strands sealed with high grade epoxy resin.
- 3 Corrosion-resistant base allows easy access to bottom connection for installation and field service.
- 4 Stainless steel connection is both tough and corrosion resistant.

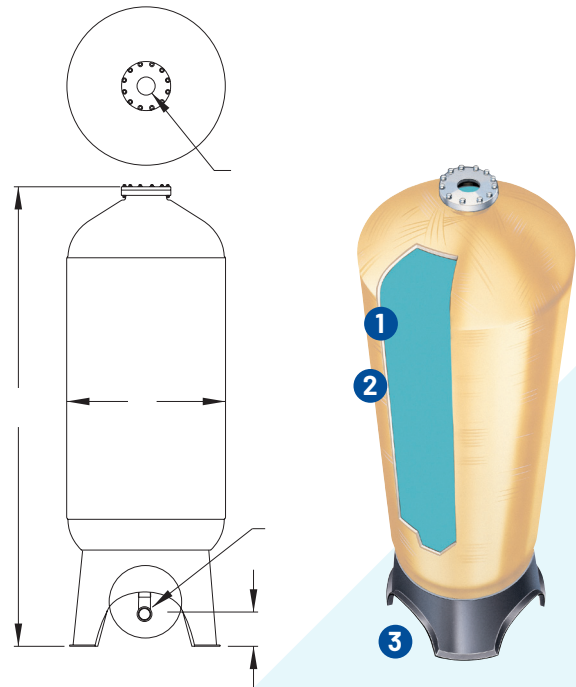

OPERATING SPECIFICATIONS

- ◆ Maximum operating pressure – 150 psig / 10 bar
- ◆ Maximum operating temperature – 120° F / 50° C

MODEL	CATALOG #	TANK CAPACITY GAL/LITER	DIAMETER A INCH/CM	HEIGHT B INCH/CM	SYSTEM CONNECTION	CONNECTION HEIGHT C INCH/CM	WEIGHT LBS/KG
RT-185F	CH32470	185/700	30/76	87/221	2" NPT	6½/17	383/173.7
RT-245F	CH32514	245/927	36/91	89/226	3" NPT	8/20	466/211.4
RT-340F	CH32432	340/1287	42/107	86/218	3" NPT	8/20	682/309.4
RT-460F	CH32515	460/1741	48/122	91/231	3" NPT	8½/22	750/340.2

Note: All dimensions are ±1".

HYDROPNEUMATIC TANK SIZING

The tank precharge fills the aircell, expanding it to the full volume of the tank liner.

As water enters the tank, it compresses the aircell which folds inward and away from the tank wall. This unique design has essentially no maximum acceptance factor limitations since the aircell equals the full inside dimension of the tank. This permits almost complete filling using wide pressure settings, enabling extended drawdown capabilities.

The stored energy in the compressed air inside the aircell pushes water out of the stainless steel bottom diffuser/outlet to the system connection.

BASIC SIZING AND SELECTION REQUIREMENTS

There are three key factors to consider when sizing the proper Pentair Comptec Tank for your system.

- ◆ The actual average delivery rate of the pump in gallons per minute (GPM).
- ◆ The recommended minimum or required pump running time.
- ◆ The minimum (cut in) and the maximum (cut out) system pressure parameters.

Once these system requirements are known, in most cases, the following calculations can easily determine the correct size and number of Pentair Comptec models needed to meet your application.

CALCULATING REQUIRED DRAWDOWN

- 1) Average pump delivery rate ___ GPM
- 2) Required minimum pump running time (Note: 1 minute 45 seconds = 1.75 minutes) ___ Minutes
- 3) Multiply line #1 by line #2. This is the minimum drawdown or available water storage volume in gallons required. ___ Gallons

CALCULATING REQUIRED TANK SIZE

- 4) Minimum system pressure ___ PSIG
- 5) Maximum system pressure ___ PSIG
- 6) Refer to the drawdown factor chart to find the drawdown percentage applicable to lines #4 and #5 ___ Factor
- 7) Divide line #3 by line #6 to determine the minimum total Comptec Tank volume required. ___ Gallons
- 8) The total gallons required equals the minimum total tank volume necessary to provide the required minimum drawdown for the system. Refer to the Comptec model data chart to select the model(s) that have a combined total tank volume that meet or exceed the required minimum volume in line #7.

NOTE: Available drawdown per tank model can be easily calculated by using the Drawdown Factor Chart Table. By finding the on/off pressure settings and the corresponding drawdown factor, you can multiply the Comptec commercial model number, which equals the total tank volume, by the drawdown factor and arrive at the drawdown for the pressure settings for that model.

Example: CPV-245 at 30 psig on / 50 psig off.

Drawdown factor = .309

$245 \times .309 = 75.7$ gallons of drawdown at 30-50 psig

TYPICAL INSTALLATION

- ◆ Never install the tank where it can freeze.
- ◆ An adequately sized pressure relief valve must be installed on the inlet line to the tank. The pressure relief valve should be sized so that enough flow can be relieved from the system to ensure that the maximum operating pressure is never exceeded. The pressure relief valve must not be isolated from the tank by a check valve, and must be set so that the maximum operating pressure is never exceeded.
- ◆ Tanks subjected to or operated in temperatures in excess of the maximum operating

temperature on the label of the tank could fail catastrophically, possibly resulting in fatal injury or property damage. This includes both internal and external temperatures.

- ◆ The base should be fully supported on all legs and bolted to the floor to ensure maximum tank stability.
- ◆ When using a pump with an air injector, the injector port must be plugged.
- ◆ The hydropneumatic tank is pre-pressurized at the factory. The precharge pressure may vary somewhat from tank to tank due to temperature and the length

of time in storage. Check and adjust the precharge according to the instruction manual when completing the installation.

- ◆ Retention tanks are rated for an internal negative pressure of 5" Hg (17 Pa) vacuum below atmospheric. If negative pressure could ever exceed 5" Hg (17 Pa), an adequate vacuum breaker must be installed.
- ◆ Retention tank top system connections must accommodate vertical expansion.

Note: All plumbing should be in compliance with local codes and standards.

Hydropneumatic Tanks

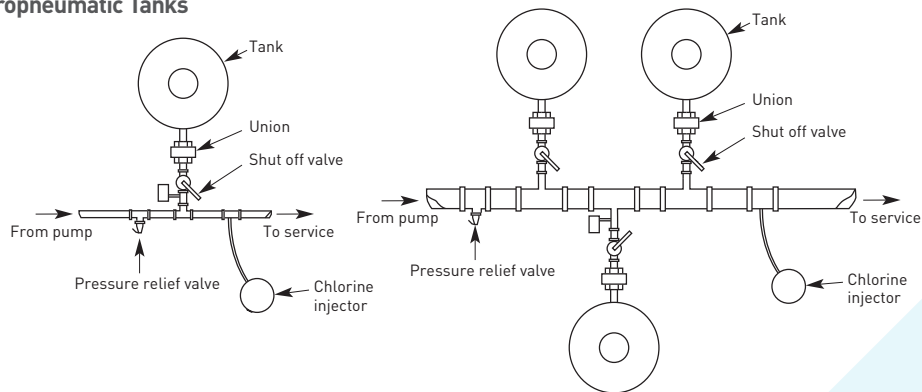

Retention Tanks

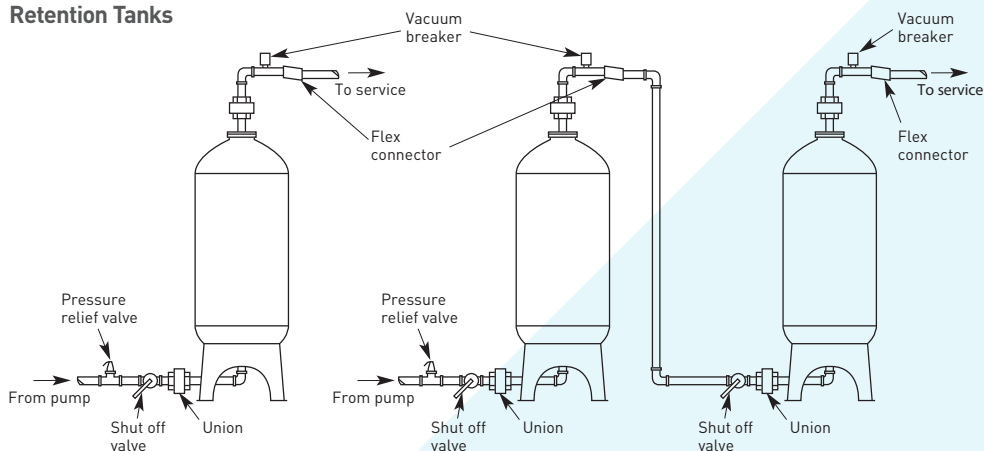

GENERAL SPECIFICATIONS LANGUAGE

The hydropneumatic tank is a pre-pressurized and sealed vessel (the retention tank shall be a sealed vessel) consisting of a composite design of a polyethylene seamless liner, reinforced with continuous strands of fiberglass covered with a two-part epoxy resin system.

SHORT FORM SPECIFICATIONS

The contractor shall provide fiberglass/composite pressure rated water system storage tanks with a diameter of ___" and overall length of ___" constructed of non-corrosive materials according to the features and dimensions shown on the drawings. The total tank capacity shall be ___ gallons/ ___ litres.

The tanks shall have a maximum operating pressure of ____ PSIG and a maximum operating temperature of 120° Fahrenheit. The laminate outer shell shall be an epoxy and continuous strand fiberglass matrix. The liner shall be seamless polyethylene as manufactured by Pentair.

The pressure tanks shall meet a design safety factor of 4 to 1 (5 to 1 for ASME) for minimum burst pressure.

LONG FORM SPECIFICATIONS

Part I. Quality Standards

1.01 Acceptable manufacturers - Pentair

Part II. Performance Standards

2.01 The maximum operating pressure of the tank shall be ___ PSIG and designed with a safety factor of 4 to 1 (5 to 1 for ASME) for minimum burst pressure.

2.02 The maximum operating temperature of the tank shall be rated at 120° Fahrenheit.

2.03 The tank shall be designed to pass a pressure cycle test of 250,000 cycles without failure.

The test will cycle from 0 psi to the maximum operating pressure for that vessel.

2.04 The tank shall be capable of withstanding negative pressure up to 5" Hg.

Part III. Inner Shell

3.01 The tank inner shell shall be constructed of seamless polyethylene material.

3.02 The tank inner shell will isolate the fluid contents of the tank to eliminate corrosion, intrusion or reaction.

Part IV. Outer Fiberglass Shell

4.01 The outer tank shell shall be constructed of continuous fiberglass roving.

4.02 The laminate matrix shall be epoxy with a glass transition

temperature of 30° Fahrenheit higher than maximum use temperature. Laminate glass volume shall be no less than 70%.

Part V. Capacity and Dimensions

5.01 The holding capacity of the tank inner shell shall be ___ gallons or ___ litres.

5.02 The tank shall have a diameter of ___" and an overall length of ___".

Part VI. Tank Openings

6.01 Threaded tank openings shall be an NPT thread specification.

Part VII. Tank Support Base

7.01 The tank support base shall allow accessibility to the bottom of the tank if required for servicing and maintenance.

7.02 Minimum tank clearance at the bottom of the tank shall be ___" as shown in the drawings provided.

ASME SECTION X FOR FRP

SECTION X OF THE ASME PRESSURE VESSEL CODE PERTAINS TO FRP PRESSURE VESSELS. THE CODE REQUIREMENTS FOR THE DESIGN AND MANUFACTURE OF THESE COMPOSITE PRESSURE VESSELS ARE AS COMPLEX AS THOSE FOR METAL, BUT VASTLY DIFFERENT.

Section X of the ASME Pressure Vessel Code pertains to fiberglass reinforced plastic (FRP) pressure vessels. The code requirements for the design and manufacture of these composite pressure vessels are as complex as those for metal, but vastly different. A Class 1 ASME pressure vessel is one which is qualified through destructive testing of a prototype.

Section X requires that a Class 1 design be qualified with a test of a prototype vessel. This prototype vessel is carefully reviewed and inspected by a third-party certified inspector. The vessel must be cycled 100,000 times over a pressure range of atmosphere-to-design pressure.

Following this, the prototype vessel must withstand a hydrostatic burst test of not less than six times design pressure. An exception to the 100,000-cycle requirement is made for vessels constructed of uncut filaments. For these vessels, the classification is designed for a 5-to-1 safety factor, requiring 33,000 atmosphere-to-design pressure cycles. These uncut filament vessels must then withstand a hydrostatic burst test of not less than five times design pressure. The code also requires the burst test pressure be applied very slowly, making for a very rigorous stress/rupture-type test.

DIFFERENT FOR METAL VESSELS

Because buyers or specifiers are familiar with the requirements of the ASME code for metal vessels, it is not uncommon to receive requests for design calculations. However, the Class 1 pressure vessels are not subject to the same design criteria as metal vessels, because of the prototype destructive qualification. Thus, design calculations alone are not meaningful.

What is meaningful to specifiers and buyers is that the prototype vessel is designed to the strict requirements of Section X; it complies with exhaustive qualification testing; and each vessel is made to the exact standards of the prototype and passes proof testing before shipment.

The proof test for an ASME composite pressure vessel requires pressurization to one and one-tenth times the design pressure. Also, the vessel cannot vary more than 5 parts per 100 in volume during expansion under pressure and it meets the exact weight limitations set by the prototype vessel.

Certified producers of composite pressure vessels under ASME Section X must develop and submit pressure vessel fabrication technologies to the Pressure Vessel Committee of the ASME. Fabricators must submit a design basis of each size of a pressure vessel, indicating diameter or length, to the ASME committee. A prototype vessel of each size is produced and proven to meet all requirements of the code by a certified third party.

Each subsequent composite pressure vessel is then produced as an exact replica of the prototype, again certified by third-party inspection. The result of this testing and inspection is a composite pressure vessel that complies completely with the ASME Pressure Vessel Code and carries the "RP" stamp.

DRAWDOWN FACTOR CHART

MINIMUM (CUT-IN) TANK PRESSURE (PSIG)

To use the factor chart, locate your cut-in pressure along the top row and read down then across to the left to find your cut-in pressure. The intersection is the drawdown factor. The drawdown factor is the percentage of the total tank volume that can be stored and delivered to service given that pressure range.

MAXIMUM (CUT-OUT) TANK PRESSURE (PSIG)	MINIMUM (CUT-IN) PRESSURE																											
	10	15	20	25	30	35	40	45	50	55	60	65	70	75	80	85	90	95	100	105	110	115	120	125	130	135	140	145
30	.447	.336	.224	.112																								
35	.503	.402	.302	.201	.101																							
40	.548	.457	.366	.274	.183	.091																						
45	.586	.503	.419	.335	.251	.168	.084																					
50	.618	.541	.464	.386	.309	.232	.155	.077																				
55	.646	.574	.502	.430	.359	.287	.215	.143	.072																			
60	.669	.602	.535	.469	.402	.335	.268	.201	.134	.067																		
65	.690	.627	.565	.502	.439	.376	.314	.251	.188	.125	.063																	
70	.708	.649	.590	.531	.472	.413	.354	.295	.236	.177	.118	.059																
75	.725	.669	.613	.557	.502	.446	.390	.334	.279	.223	.167	.111	.056															
80	.739	.686	.634	.581	.528	.475	.422	.370	.317	.264	.211	.158	.106	.053														
85	.752	.702	.652	.602	.552	.502	.451	.401	.351	.301	.251	.201	.150	.100	.050													
90	.764	.716	.669	.621	.573	.525	.478	.430	.382	.334	.287	.239	.191	.143	.096	.048												
95	.775	.729	.684	.638	.593	.547	.501	.456	.410	.365	.319	.273	.228	.182	.137	.091	.046											
100	.785	.741	.697	.654	.610	.567	.523	.480	.436	.392	.349	.305	.262	.218	.174	.131	.087	.044										
105	.794	.752	.710	.668	.627	.585	.543	.501	.459	.418	.376	.334	.292	.251	.209	.167	.125	.084	.042									
110	.802	.762	.722	.682	.642	.601	.561	.521	.481	.441	.401	.361	.321	.281	.241	.200	.160	.120	.080	.040								
115	.810	.771	.732	.694	.655	.617	.587	.540	.501	.463	.424	.386	.347	.308	.270	.231	.193	.154	.116	.077	.039							
120	.817	.780	.742	.705	.668	.631	.594	.557	.520	.483	.445	.408	.371	.334	.297	.260	.223	.186	.148	.111	.074	.037						
125	.823	.787	.752	.716	.680	.644	.608	.573	.537	.501	.465	.429	.394	.358	.322	.286	.251	.215	.179	.143	.107	.072	.036					
130	.829	.795	.760	.726	.691	.657	.622	.587	.553	.518	.484	.449	.415	.380	.346	.311	.276	.242	.207	.173	.138	.104	.059	.035				
135	.835	.802	.768	.735	.701	.668	.635	.601	.568	.534	.501	.468	.434	.401	.367	.334	.301	.267	.234	.200	.167	.134	.100	.067	.033			
140	.840	.808	.776	.743	.711	.679	.646	.614	.582	.549	.517	.485	.452	.420	.388	.356	.323	.291	.259	.226	.194	.162	.129	.097	.065	.032		
145	.845	.814	.783	.751	.720	.689	.657	.626	.595	.564	.532	.501	.470	.438	.407	.376	.344	.313	.282	.250	.219	.188	.157	.125	.094	.063	.031	
150	.850	.820	.789	.759	.729	.698	.668	.638	.607	.577	.546	.516	.486	.455	.425	.395	.364	.334	.304	.279	.243	.213	.182	.152	.121	.091	.061	.030

RESIDENTIAL TANK REPLACEMENT GUIDE

	WM-4	WM-6	WM-9	WM-12	WM-14WB	WM-20WB	WM-23	WM-25WB	WM-35WB
QUICK CONNECT	CH34717	34718	34719	34720	34721	CH34723	CH34722	34724	34725
THREADED	CH30837	CH30840	CH30854	CH30866	CH30951	CH31050	CH32855	CH31056	CH31062
GALLONS	14	20	30	40	47	60	80	87	119
Amtrol Well-X-Trol	WX-200	WX-202	WX-203	WX-205	WX-250	WX-251	WX-255	WX-302	WX-350
	WX-201			WX-250					
Amtrol Champion	CH-14	CH-20	CH-26	CH-34	CH-44	CH-62	CH-81	CH-86	CH-119
			CH-32						
Amtrol Wel-Flo	WF-14	WF-20	WF-26	WF-34	WF-44	WF-62	WF-81	WF-86	WF-119
			WF-32						
Amtrol Pro-Line	PL-14	PL-20	PL-26	PL-34	PL-44	PL-62	PL-81	PL-86	PL-119
			PL-32						
Flexcon Well-Rite	WR 45	WR 60	WR 80	WR 120	WR 140	WR 200	WR 240	WR 260	WR 360
			WR 100						
Flexcon H2P	H2P 14	H2P 20	H2P 25	H2P 35	H2P 45	H2P 65	H2P 80	H2P 85	H2P 120
			H2P 30						
Flexcon Challenger	PC 44	PC 66	PC 88	PC 122	PC 144	PC 211	PC 244	PC 266	PC 366
			PC 111						
Flexcon WWT	WWT 14	WWT 20	WWT 25	WWT 35	WWT 45	WWT 65	WWT 80	WWT 85	WWT 120
			WWT 30						
Flexcon Flex2Pro	-	F2P 20	F2P 26	F2P 32	F2P 44	F2P 65	F2P 81	F2P 85	F2P 119
Flexcon Pro Lite	CSS 15	CSS 22	-	CSS 35	CSS 50	CSS 65	CSS 82	CSS 90	CSS 120
Flexcon Flex-Lite	FL 5	FL 7	-	FL 12	FL 17	FL 22	FL 28	FL 30	FL 40
				FL 13SQ					
				FL 14					
Flexcon H2PL	H2PL 15	H2PL 22	-	H2PL 35	H2PL 50	H2PL 65	H2PL 82	H2PL 90	H2PL 120
				H2PL 38SQ					
				H2PL 42					
A.O. Smith ProMax	PMX-14	PMX-20	PMX-32	PMX-36	PMX-52	PMX-65	PMX-86	PMX-96	PMX-119
	PMXP-14	PMXP-20	PMXP-32	PMXP-36	PMXP-52	PMXP-65	PMXP-86	PMXP-96	PMXP-119
		PMXE-20	PMXE-32	PMXE-36S	PMXE-52	PMXE-65	PMXE-86		PMXE-119
ProSource Steel Tanks	-	PS19S-T02	PS32-T03	PS35-T05	PS50-T50	PS62-T51	-	PS85-T52	PS119-TR50
		PS19T-T02							
ProSource Plus Steel Tanks	-	PSP19S-T02	PSP32-T03	PSP35-T05	PSP50-T50	PSP62-T51	-	PSP85-T52	PSP119-TR50
		PSP19T-T02							
ProSource PSC	PSC-14-4	PSC-20-6	PSC-30-9	PSC-40-12	PSC-48-14	PSC-60-20	PSC-80-23	PSC-85-25	PSC-119-35
Composite Tanks									
Goulds HydroPro	V45	V60	V80	V100S	V140	V200	V250	V260	V350
			V80EX						
			V100						

NOTES:

NOTES:



293 Wright St
Delavan, WI 53115
Ph: 888.987.8677
Fx: 800.426.9446

490 Pinebush Rd, Unit 4
Cambridge, Ontario
Canada N1T 0A5
Ph: 800.363.7867
Fx: 888.606.5484

pentair.com

All indicated Pentair trademarks and logos are property of Pentair. Third party registered and unregistered trademarks and logos are the property of their respective owners. Because we are continuously improving our products and services, Pentair reserves the right to change specifications without prior notice. Pentair is an equal opportunity employer.